

Design of a Compact Lowpass-Bandpass Diplexer with High Isolation

Seda Elden¹ and Ali K. Gorur^{2, *}

Abstract—In this paper, a novel compact lowpass-bandpass microstrip diplexer with high isolation is proposed. The proposed structure consists of a lowpass filter section and a bandpass filter section. The lowpass filter section is designed at a cut-off frequency of 2 GHz with sixth order elliptic filtering characteristics. The bandpass filter section is designed at 3.5 GHz by using a meandered dual-mode loop resonator (MDMLR). The MDMLR is coupled to input port by open circuited feeding lines. The lowpass-bandpass diplexer is formed by combining lowpass and bandpass filter sections without using an additional matching circuit. The designed lowpass-bandpass diplexer has been fabricated and measured in a very good agreement with the simulated results. Isolation between the output ports has been measured as better than 40 dB.

1. INTRODUCTION

Depending on the growing market of the satellite and space communication systems, requirement of multifunctional circuits gets increased. Since multiplexers can serve at more than one frequency channel, they are generally preferred in many communication systems. In addition, lowpass-bandpass diplexers can also fulfill two tasks such as lowpass and bandpass filtering responses by means of only one circuit.

Although there are many diplexers having bandpass channels, the number of lowpass-bandpass diplexers is relatively low. In [1], a lowpass-bandpass diplexer with high isolation has been reported by locating the bandpass channel at the transmission zero frequency of the lowpass channel. However, the designed diplexer suffers from high insertion losses in both channels, and the lowpass channel is not sharp. In order to provide independent design process for lowpass and bandpass channels, a matching circuit has been introduced in [2]. In [3], a systematic matching design has also been introduced by using an integrated matching circuit and a direct-feed coupled resonator bandpass filter. Although this circuit removed the requirement of additional circuit line, isolation and circuit size were not good enough. In [4] and [5], lowpass-bandpass diplexers have been reported by using conventional design methods at lowpass channel, and only one transmission pole can be obtained in the bandpass channels. In these studies, selectivity of the bandpass channels is not good enough, and they also suffer from large circuit size and low isolation. In addition, novel lowpass filter sections have been introduced in [6–8, 13, 14] for lowpass-bandpass diplexer design. However, single transmission pole is observed in the bandpass channel in [6], and isolation levels are not good enough in [7, 8, 13, 14]. Besides, lowpass-bandpass triplexers [9, 10] and a quintuplexer [9] have also been reported based on distributed coupling technique [9] and defected ground structures [10]. However, they have large circuit area since the bandpass channels have been realized by multiple resonators. To the best of our knowledge, dual-mode ring resonators have not yet been used in lowpass-bandpass diplexers. They can provide high isolation, small circuit size, and no matching circuit is required.

In this letter, a novel lowpass-bandpass diplexer with high isolation and good channel performances is proposed. The proposed circuit is constructed by the direct combination of lowpass and bandpass

Received 27 January 2021, Accepted 10 March 2021, Scheduled 15 March 2021

* Corresponding author: Ali Kursad Gorur (kgorur@nevsehir.edu.tr).

¹ Department of Electrical and Electronics Engineering, Avrasya University, Trabzon 61100, Turkey. ² Department of Electrical and Electronics Engineering, Nevsehir Haci Bektas Veli University, Nevsehir 50300, Turkey.

filter sections. By means of the proposed approach, no matching circuit is required, and a small circuit size can be achieved. The lowpass filter section is designed by using sixth order elliptic filtering characteristics [11]. A meandered dual-mode loop resonator (MDMLR) coupled to input/output (I/O) ports is utilized for the bandpass filter section. Cut-off and center frequencies of the lowpass and bandpass filters are adjusted to 2 GHz and 3.5 GHz, respectively. The designed diplexer has been fabricated and tested in a very good agreement with the predicted results.

2. DESIGN PROCEDURE

2.1. Lowpass Filter Design

In order to design a lowpass-bandpass diplexer, a lowpass filter section is firstly designed by using the conventional design approaches described in [11]. Since elliptic function lowpass filters provide transmission zeros in the upper stopband, they are useful for increasing the isolation level between the output ports for the diplexer design. High isolation can be achieved by obtaining a stopband attenuation of better than 30 dB. In addition, selectivity of the filter can be increased by decreasing Ω_s , which is the equal-ripple stopband starting frequency [11]. Accordingly, sixth order elliptic filtering characteristics can be chosen in order to obtain a stopband attenuation of better than 30 dB and to have the possible minimum Ω_s . A lumped element lowpass filter model for sixth order elliptic filtering characteristics is shown in Fig. 1(a). In this figure, element values for the lowpass filter prototype are chosen as $g_0 = g_7 = 1$, $g_1 = 0.6549$, $g_2 = 1.0036$, $g'_2 = 0.4597$, $g_3 = 1.0923$, $g_4 = 0.7731$, $g'_4 = 0.9284$, $g_5 = 1.0406$, and $g_6 = 1.0214$. The corresponding minimum stopband attenuation (L_{As}) is 32.41 dB at $\Omega_s = 1.158$, and the passband ripple (L_{Ar}) is 0.1 dB (Table 3.3 in [11]). For the cut-off frequency (f_c) of 2 GHz, L-C element values of the lowpass filter can be calculated by [11],

$$L_i = \frac{1}{2\pi f_c} Z_0 g_{L_i} \quad \text{and} \quad C_i = \frac{1}{2\pi f_c} \frac{1}{Z_0} g_{C_i} \quad (1)$$

where Z_0 is the I/O terminal impedance as 50 ohms. The corresponding L-C values are $L_1 = 2.61$, $L_2 = 1.83$, $L_3 = 4.35$, $L_4 = 3.69$ nH and $C_2 = 1.60$, $C_4 = 1.23$, $C_6 = 1.60$ pF. Microstrip layout of the

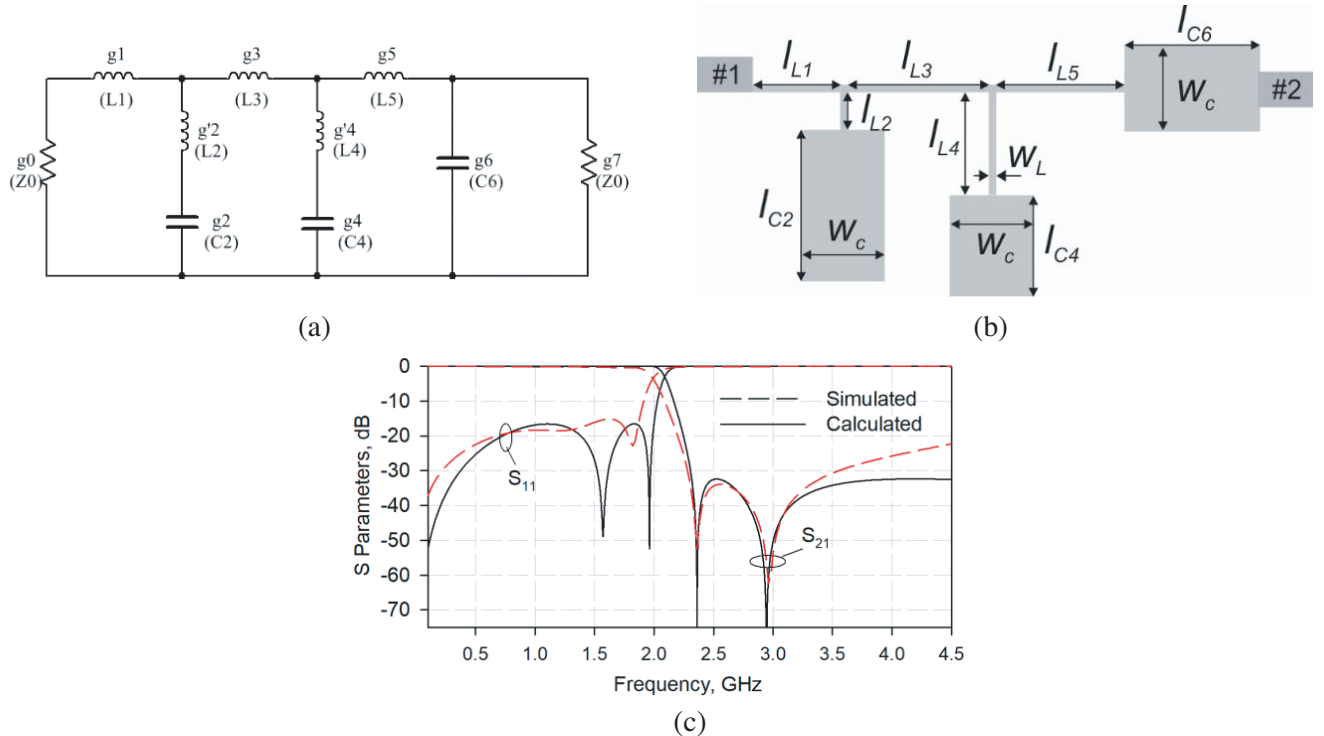

Figure 1. (a) Conventional sixth order elliptic function lowpass filter model. (b) Layout of the microstrip lowpass filter. (c) Frequency response of the lowpass filter.

lowpass filter shown in Fig. 1(b) can be realized by obtaining the required transmission line lengths from [11],

$$l_{Li} = \frac{\lambda_{gL}(f_c)}{2\pi} \sin^{-1} \left(2\pi f_c \frac{L_i}{Z_{0L}} \right) \quad (2)$$

$$l_{Ci} = \frac{\lambda_{gC}(f_c)}{2\pi} \sin^{-1} (2\pi f_c C_i Z_{0C}) \quad (3)$$

where λ_{gL} and λ_{gC} are guided wavelengths for inductors and capacitors, respectively. For the microstrip realizations, an RO4003C substrate with a dielectric constant of 3.38 and a thickness of 0.813 mm is used. $Z_{0L} = 107 \Omega$ and $Z_{0C} = 27 \Omega$ are characteristic impedances of high and low impedance transmission lines, respectively. They are determined depending on the simple practical physical dimensions of $w_L = 0.4$ and $w_C = 4.5$ mm, respectively. From Eq. (2), lengths of the lowpass filter can be obtained as $lL_1 = 4.77$, $lL_2 = 3.32$, $lL_3 = 8.21$, $lL_4 = 6.88$, $lL_5 = 7.78$, $lC_2 = 8.09$, $lC_4 = 6.08$, $lC_6 = 8.25$ mm. In order to remove the reactance and susceptance resulting from the junctions, compensations must be applied [11]. After compensations, the final dimensions can be found as $lL_1 = 4.77$, $lL_2 = 2.05$, $lL_3 = 8.21$, $lL_4 = 5.59$, $lL_5 = 6.87$, $lC_2 = 8.07$, $lC_4 = 5.43$, $lC_6 = 7.33$ mm. Calculated and simulated frequency responses of the designed lowpass filter are illustrated in Fig. 1(c).

2.2. Lowpass Bandpass Diplexer Design

After completing the lowpass filter section, lowpass-bandpass diplexer can be designed by directly adding the bandpass filter section. Based on this design approach, no matching circuit is required. For this purpose, an MDMLR can be coupled to I/O ports by means of open circuited feeding lines as shown in Fig. 2. As can be seen from the figure, the MDMLR has four meandered sections to achieve circuit size reduction. Electrical length of an edge of the MDMLR including only one meandered section is $\lambda/4$, while the remaining path has three meandered sections having an electrical length of $3\lambda/4$. As well known from [12], dual-mode ring resonators can be excited by a patch perturbation element to obtain filtering characteristics with two imaginary-axis transmission zeros. Therefore, a small patch is located in the symmetrical axis of the MDMLR. The designed diplexer allows controlling the center frequency of the bandpass channel by changing the lengths of the meandered section, d . Effects of the changes in d on the frequency response are demonstrated in Fig. 3(a). As can be seen from the figure, bandpass channel can be easily controlled in a wide range approximately between 2.5 GHz and 4 GHz. It should be noted that the cut-off frequency of the lowpass channel and also the total circuit size are kept while the center frequency is controlled. Fractional bandwidth (*FBW*) and coupling coefficient

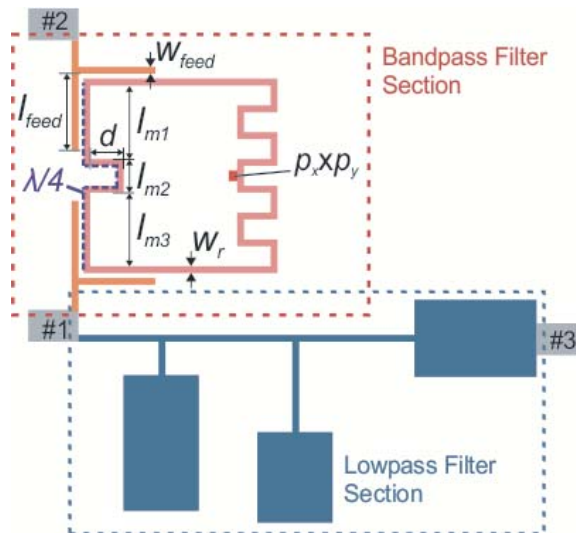

Figure 2. Configuration of the proposed lowpass-bandpass diplexer.

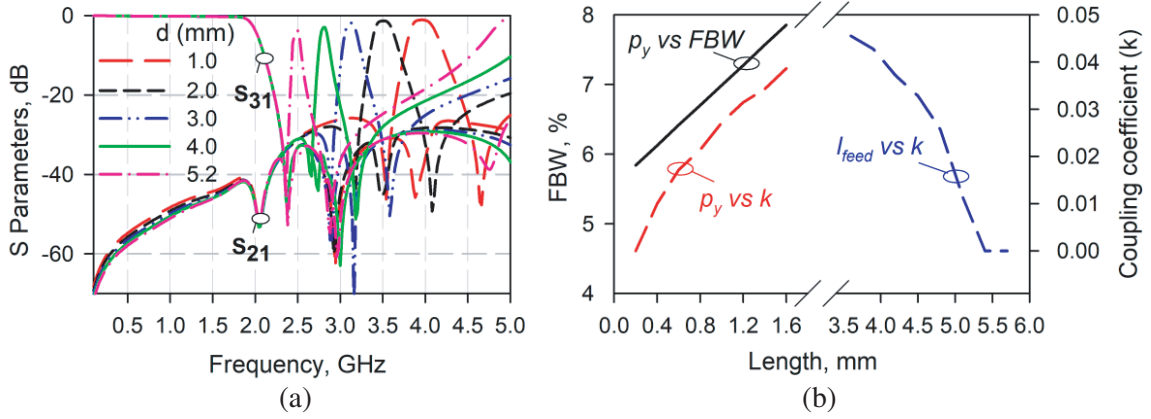

Figure 3. (a) Center frequency control mechanism of the bandpass channel with respect to the changes in d , (b) Effects of p_y and l_{feed} on the FBW and k .

(k) of the bandpass channel can be controlled by the perturbation element and feeding lines. Fig. 3(b) represents the effects of perturbation element dimension (p_y) and lengths of feeding lines on the FBW and k . It is obvious that the bandwidth of the bandpass channel can be easily controlled by changing the dimensions of the patch perturbation element (p_x or p_y). In-band return loss level of the bandpass channel can also be adjusted with respect to the changes in the length of the feeding line (l_{feed}).

3. EXPERIMENTAL STUDIES

To demonstrate the validity of the proposed approach, a lowpass-bandpass diplexer was fabricated on a Rogers RO4003C substrate ($\epsilon_r = 3.38$, $h = 0.813$ mm). The final dimensions of the designed diplexer given in Fig. 2 are decided according to Figs. 3(a) and 3(b). At this stage Full-Wave Electromagnetic Simulator has been utilized to obtain the best possible diplexer performance in terms of isolation, return losses, and insertion losses [15]. Accordingly, final dimensions have been determined to achieve the following conditions;

- Isolation between the output ports is better than 40 dB.
- Return losses inside the passband and lowpass regions are better than 15 dB.
- Insertion loss inside the passband is better than 1.3 dB.

Final dimensions are $l_{feed} = 5$, $d = 2$, $p_x = 0.5$, $p_y = 0.6$, $W_{feed} = W_r = 0.4$, $l_{m1} = l_{m3} = 4.4$, $l_{m2} = 0.2$ mm. The overall circuit size is about $0.30\lambda_g \times 0.31\lambda_g$, where λ_g is the guided wavelength at the cut-off frequency of the lowpass channel. The fabricated diplexer was measured by a Keysight N5222A PNA Network Analyzer in a very good agreement with the simulated results. The measured and simulated frequency responses are illustrated in Fig. 4. A photograph of the fabricated filter is also shown in Fig. 4. The measured cut-off and center frequencies are 2 GHz and 3.5 GHz, respectively. 3-dB FBW of the bandpass channel is 5.5%. Insertion losses at the lowpass and bandpass channels were measured as 0.3 and 1.28 dB, respectively. Return loss of the lowpass channel is better than 15 dB, while the mid-band return loss level is 22 dB for the bandpass channel. Isolation between the outputs was measured as better than 40 dB.

Comparisons of the designed lowpass-bandpass diplexer with the existing studies in the literature are given in Table 1. The proposed circuit is the first type constructed by an MDMLR, and no additional matching circuit is needed. Thus, a compact circuit size can be achieved with high isolation between the outputs. Although high isolation has also been obtained in [1] and [10], the total circuit size of the proposed structure is quite low. Moreover, the proposed diplexer has higher order at the lowpass channel than [1] and [10]. On the other hand, the diplexers in [2] and [3] have lower performance in terms of circuit size and isolation level. Although the diplexers in [7, 8, 13, 14] have more compact circuit size, isolation levels are not as good as the proposed work.

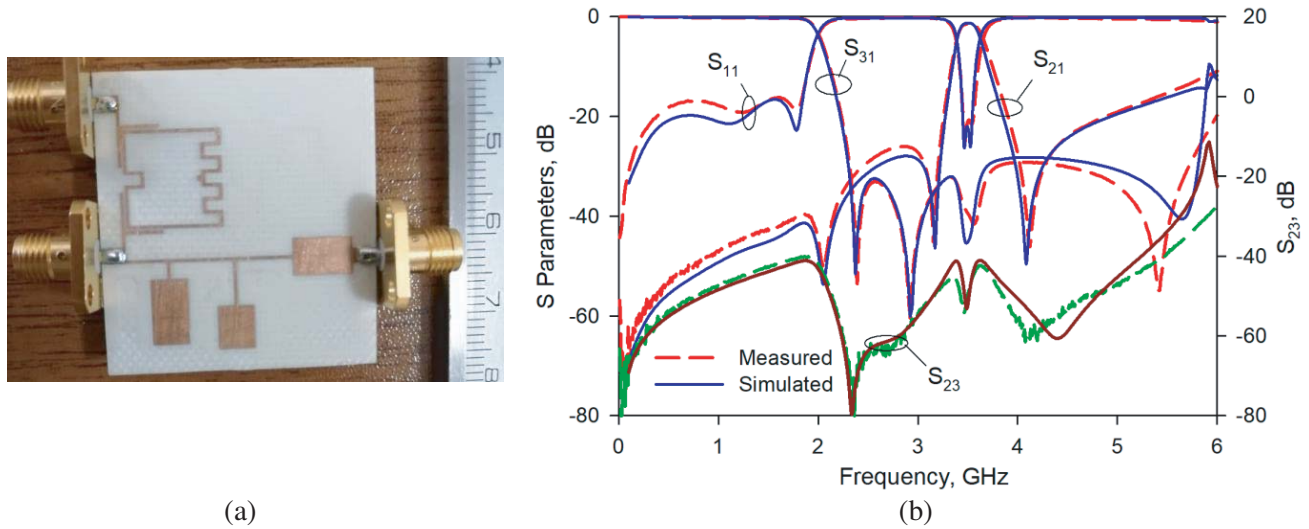

Figure 4. (a) Photograph of the fabricated diplexer. (b) Comparisons of the measured and simulated results.

Table 1. Comparisons with previous lowpass-bandpass diplexers.

Ref.	f_c/f_0 (GHz)	FBW (%)	IL (dB) LPC, BPC	I (dB)	S (λ_g) ²
[1]	0.6/2.4	*n	< 1, 4.8	> 51	*n
[2]	1.5/2.4	8	< 0.25, 2.42	> 35	0.49
[3]	1.5/2.4	10.5	0.3, 1.2	> 30	0.298
[7]	2.4/4.2	15.2	0.18, 0.18	26	0.036
[8]	1.88/3.56	23.8	0.12, 0.1	26	0.03
[10]	1/2.4, 5.8	10/7	< 0.8, 2.1, 2.5	> 40	0.402
[13]	1.57, 3.35	4.7	0.01, 0.26	> 21	0.018
[14]	2.64, 3.73	18.5	0.2, 0.25	> 21	0.075
T.W.	2/3.5	5.4	0.3, 1.28	> 40	0.095

LPC: Lowpass Channel, BPC: Bandpass Channel, T.W.: This Work, I: Isolation, S: Size, *n: no information

4. CONCLUSION

A novel compact lowpass-bandpass microstrip diplexer was designed by combining an elliptic function lowpass filter and a dual-mode bandpass filter. The dual-mode bandpass filter has been constructed by coupling an MDMLR with open ended feeding lines. Since an additional matching circuit is not needed, the proposed diplexer has a very compact circuit size. Cut-off frequency of the lowpass channel and the center frequency of the bandpass channel were adjusted to 2 GHz and 3.5 GHz, respectively. The proposed circuit has also been fabricated and measured for the experimental verification. Isolation between the output ports was observed as better than 40 dB.

ACKNOWLEDGMENT

This work was supported by the Research Fund of the Nevsehir Haci Bektas Veli University. Project Number: ABAP20F3.

REFERENCES

1. Capstick, M. H., "Microstrip lowpass-bandpass diplexer topology," *Electron. Lett.*, Vol. 35, No. 22, 1958–1960, Oct. 1999.
2. Deng, P. and J. Tsai, "Design of microstrip lowpass-bandpass diplexer," *IEEE Microwave and Wireless Components Letters*, Vol. 23, No. 7, 332–334, Jul. 2013.
3. Deng, P., R. Liu, W. Lin, and W. Lo, "Design of a microstrip low-pass-bandpass diplexer using direct-feed coupled-resonator filter," *IEEE Microwave and Wireless Components Letters*, Vol. 27, No. 3, 254–256, Mar. 2017.
4. Perez-Wences, C., J. Loo-Yau, I. Lavandera-Hernandez, P. Moreno, A. Reynoso, and L. M. Aguilar Lobo, "Compact microstrip lowpass-bandpass diplexer using radial stubs," *Microwave and Optical Technology Letters*, Vol. 61, No. 2, 485–489, Feb. 2019.
5. Rayatzadeh, S. and G. Moloudian, "Design and fabrication of a miniaturized lowpass-bandpass diplexer with wide tuning range and high isolation," *Journal of Electromagnetic Waves and Applications*, Vol. 33, No. 14, 1874–1889, Jul. 2019.
6. Heshmati, H. and S. Roshani, "A miniaturized lowpass bandpass diplexer with high isolation," *AEU — International Journal of Electronics and Communications*, Vol. 87, 87–94, Apr. 2018.
7. Rezaei, A., L. Noori, and M. H. Jamaluddin, "Novel microstrip lowpass-bandpass diplexer with low loss and compact size for wireless applications," *AEU — International Journal of Electronics and Communications*, Vol. 101, 152–159, Mar. 2019.
8. Hayati, M., A. Rezaei, and L. Noori, "Design of a high-performance lowpass-bandpass diplexer using a novel microstrip structure for GSM and WiMAX applications," *IET Circuits, Devices & Systems*, Vol. 13, No. 3, 361–367, Apr. 2019.
9. Tu, W. and C. Wu, "Design of microstrip low-pass-bandpass multiplexers using distributed coupling technique," *IEEE Transactions on Components, Packaging and Manufacturing Technology*, Vol. 6, No. 11, 1648–1655, Nov. 2016.
10. Chen, F., J. Qiu, H. Hu, Q. Chu, and M. J. Lancaster, "Design of microstrip lowpass-bandpass triplexer with high isolation," *IEEE Microwave and Wireless Components Letters*, Vol. 25, No. 12, 805–807, Dec. 2015.
11. Hong, J. S. and M. J. Lancaster, *Microstrip Filters for Rf/Microwave Applications*, Wiley, New York, 2001.
12. Gorur, A., "Description of coupling between degenerate modes of a dual-mode microstrip loop resonator using a novel perturbation arrangement and its dual-mode bandpass filter applications," *IEEE Transactions on Microwave Theory and Techniques*, Vol. 52, No. 2, 671–677, Feb. 2004.
13. Yahya, S. I., A. Rezaei, and L. Nouri, "A novel miniaturized microstrip lowpass bandpass diplexer using patch and interdigital cells for wireless networks," *AEU — International Journal of Electronics and Communications*, Vol. 126, No. 1434–8411, Nov. 2020.
14. Nouri, L., S. Yahya, and A. Rezaei, "Design and fabrication of a low-loss microstrip lowpass-bandpass diplexer for WiMAX applications," *China Communications*, Vol. 17, No. 6, 109–120, Jun. 2020.
15. *Sonnet User's Manual*, Version 16, Sonnet Software, North Syracuse, NY, 2016.