

Compact D-CRLH Structure for Filtering Power Divider

Dilip Kumar Choudhary and Raghvendra Kumar Chaudhary*

Abstract—This research work introduces a compact dual composite right/left handed (D-CRLH) unit cell structure for filtering power divider (FPD) application. The D-CRLH unit-cell consists of an interdigital capacitor with two shorted fingers in series. It contains a meander line, a rectangular stub, and a via in shunt, both series and shunt elements provide filtering response as a bandpass filter. This design has been developed on dielectric material of thickness 1.6 mm, usually called as Epoxy glass substrate (FR-4). The transmission line of length $\lambda_g/4$ of a Wilkinson power divider has been replaced with a D-CRLH unit cell to reduce the size of proposed structure more than 60%. Another advantage of using a D-CRLH structure is the position of resonance frequency independently controlled by series parameter only because of shorted structure. The series chip resistor has been utilized to improve the isolation at resonance in between output ports. It offers miniaturization with electrical footprint area of $0.15\lambda_g \times 0.27\lambda_g$ (11.4 mm \times 20.4 mm), here λ_g represents the guided wavelength at resonance frequency of 2.5 GHz.

1. INTRODUCTION

Metamaterials (MTMs) are purposely engineered electromagnetic homogeneous structures, having their size substantially smaller than guided wavelength (λ_g). They offer some unusual and advantageous things corresponding to negative index of refraction, negative value of permittivity, negative value of permeability, and zero propagation constant [1, 2]. Transmission line approach of MTM utilizes composite right/left handed (CRLH) or dual composite right-left handed (D-CRLH) structure. CRLH transmission line structure utilizes series combination of lumped LC tank circuit in series and parallel combination of LC tank circuit in shunt [3].

The dual composite right/left handed (D-CRLH) resonator structure contains parallel combination of an inductor and a capacitor in series and series combination of a capacitor and an inductor in shunt LC tank circuit and shunt series LC circuit, whereas CRLH unit cell uses series combination of an inductor and a capacitor in series and parallel combination of a capacitor and an inductor in shunt [4]. The D-CRLH unit cell displays left-handed behavior of metamaterial at higher frequency and right-handed behavior at lower frequency, opposite to CRLH structure [5]. Recent communication system includes compact and cost-effective multi-functional microwave devices. To accommodate this, multi-functional microwave circuits have been drawing more attention [6]. Power divider is an important component used in transceiver as power combining and division [7]. Wilkinson power divider divides input power signal into two equal phase power at output and preferably used for low power application [8]. It has been found in literature that the selectivity of a Wilkinson power divider has been enhanced by incorporating a bandpass filter [9]. The transmission line of quarter wavelength (QW-TL) of a Wilkinson power divider has been substituted with a bandpass filter to get power division and filter response simultaneously, known as filtering power divider (FPD) [10]. In [11, 12] filtering power divider has been

Received 15 July 2020, Accepted 29 October 2020, Scheduled 6 November 2020

* Corresponding author: Raghvendra Kumar Chaudhary (raghvendra.chaudhary@gmail.com).

The authors are with the Department of Electronics Engineering, Indian Institute of Technology (Indian School of Mines) Dhanbad, Dhanbad, Jharkhand 826004, India.

designed with wide stopband bandwidth using coupled line structures. A miniaturised FPD by high selectivity was proposed [13], which replaced the QW-TL of a Wilkinson power divider with two tri-mode resonators. The in-band isolation has been improved by replacing the QW-TL of a power divider with a capacitor loaded filter [14]. Using coupled resonator technology, compact FPD has been proposed with improved selectivity [15]. The power divider with dual passband response has been designed with a transmission line using capacitive loading with ultra-wideband harmonic suppression [16]. A wideband power divider by bandpass filtering response has been designed with an interdigital coupled line and a stepped impedance ring resonator [17, 18]. A power divider with dual stopband response has been designed using a D-CRLH structure [19]. An FPD has been designed with the help of a stepped impedance resonator for good in-band isolation [20]. Compactness has been achieved due to a complementary split ring resonator in [21]. A compact wideband filtering power divider has been designed using a CRLH bandpass filter with the unit cell size of $\lambda_g/17$ at its resonance frequency [22].

A compact metamaterial D-CRLH unit cell has been designed and replaced with a transmission line of length $\lambda_g/4$ of a power divider to form a filtering power divider, which is presented in this paper. To further miniaturize the structure size, a common shorting point is used for both the unit cells in FPD. Isolation is improved by using 100 ohm resistance in between output ports. The change in resonance frequency and transmission zero is achieved by varying the series parameter (length of the interdigital capacitor) due to short ended boundary condition.

2. DESIGN AND ANALYSIS OF D-CRLH UNIT CELL

The geometrical structure of designed metamaterial D-CRLH resonator with its scattering parameters and equivalent circuit diagram are shown Fig. 1(a) and Fig. 1(b), respectively. The proposed structure is composed using an interdigital capacitor with two shorted fingers in series and in a shunt meander line connected with a rectangular stub, grounded using a via. In series, inductance L_p is generated by a feed line, capacitance C_L associated with an interdigital capacitor (IDC), and inductance L_R appears due to two shorted fingers of IDC. In shunt, the inductances L_{L1} and L_{L2} are associated with the meander line and via (connect rectangular stub to ground plane), and capacitance C_s id due to the rectangular stub. The capacitance C_R appears due to the substrate between ground plane and IDC.

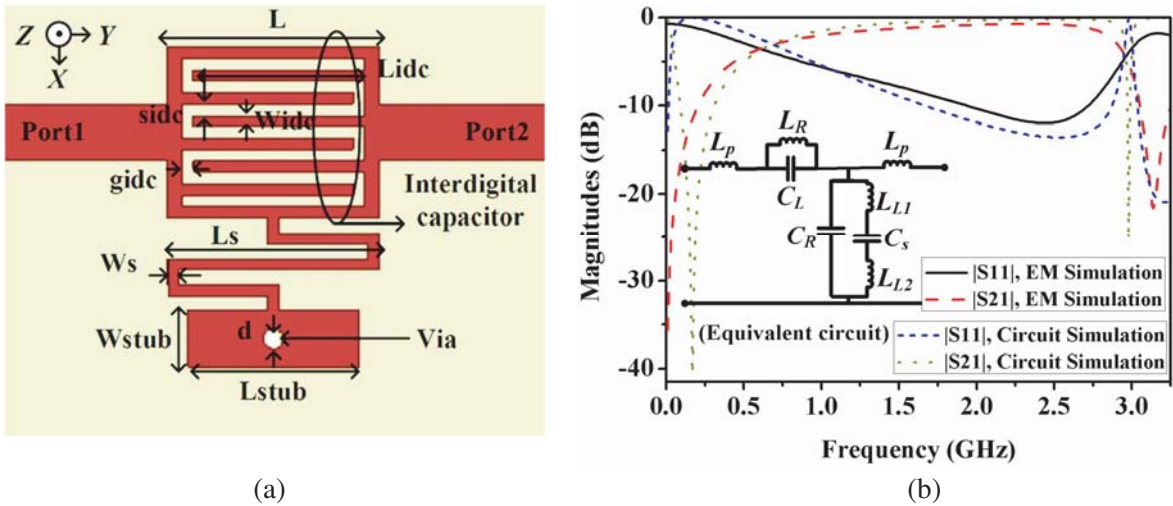

Figure 1. D-CRLH unit cell. (a) Structural layout. (b) Scattering parameters and equivalent circuit.

The designed unit cell resonates at frequency of 2.5 GHz, and its minimum transmission coefficient is 0.2 dB at resonance frequency. By assuming the resonance frequency of 2.5 GHz, a short-ended lumped equivalent circuit has been drawn based on D-CRLH metamaterial properties. The series and shunt parameter is optimised to get the desired resonance frequency on ADS circuit simulator. Initial lumped values are calculated using equivalent circuit model such as: $L_p = 1.1$ nH, $L_R = 372$ nH, $C_L = 2.4$ pF,

$L_{L1} = 66$ nH, $L_{L2} = 29$ nH, $C_R = 0.56$ pF, and $C_s = 0.03$ pF. The structural layout is calculated using the following design formulas for distributed elements [4, 25]. The optimized structural parameters are $L = 7.4$, $Lidc = 6.0$, $Widc = 0.4$, $sidc = 0.4$, $gdc = W_s = 0.4$, $L_s = 7.4$, $d = 0.7$, $Wstub = 2.0$, and $Lstub = 6.0$ (all dimensions are in mm).

$$C_L \text{ (pF)} = (\varepsilon_r + 1) Lidc [(N_f - 3)A_0 + A_1] \quad (1)$$

$$L_R \text{ (nH)} = 2 \times 10^{-4} L \left[\ln \left(\frac{L}{Widc + t} \right) + 1.193 + \frac{Widc + t}{3L} \right] \cdot kg \quad (2)$$

$$L_{L1} \text{ (nH)} = 2 \times 10^{-4} L_s \left[\ln \left(\frac{L_s}{W_s + t} \right) + 1.193 + \frac{W_s + t}{3L_s} \right] \cdot kg \quad (3)$$

$$L_{L2} \text{ (nH)} = 0.2 \left[hsub - \ln \left(\frac{hsub + \sqrt{r^2 + hsub^2}}{r} \right) + 1.5 \left(r - \sqrt{r^2 + hsub^2} \right) \right] \quad (4)$$

$$A_0 = 4.40 \tanh [0.55(hsub/Widc)^{0.45}] \times 10^{-6} \quad (5a)$$

$$A_1 = 9.92 \tanh [0.52(hsub/Widc)^{0.5}] \times 10^{-6} \quad (5b)$$

$$kg = 0.57 - 0.145 \ln(Widc/hsub) \quad (5c)$$

where ε_r is the permittivity of substrate, L ($L = Lidc + gdc$) the length of microstrip line, L_s is length of meander line, W_s is the width of meander line, t the thickness of printed copper, and $hsub$ the substrate thickness. N_f represents the number of interdigital capacitor finger, and $r = d/2$ is the radius of via. From the equivalent circuit of proposed D-CRLH resonator, the value of series impedance (Z_{se}) and value of shunt admittance (Y_{sh}) are as follows:

$$Z_{se} = 2j\omega L_p + \frac{j\omega L_R}{1 - \omega^2 L_R C_L} = \frac{j\omega [(2L_p + L_R) - 2\omega^2 L_p L_R C_L]}{1 - \omega^2 L_R C_L} \quad (6)$$

$$Y_{sh} = j\omega C_R + \frac{j\omega C_s}{1 - \omega^2 (L_{L1} + L_{L2}) C_s} = \frac{j\omega [(C_R + C_s) - \omega^2 (L_{L1} + L_{L2}) C_s C_R]}{1 - \omega^2 (L_{L1} + L_{L2}) C_s} \quad (7)$$

The suggested D-CRLH unit cell structure is designed with shorted boundary conditions, so that input impedance is directly proportionate with series impedance (Z_{se}) and a integer of unit cells (N), shown in Eq. (8). In designed filter, the number of unit cell is one.

$$Z_{in}^{short} = -jZ_0 \cot(\beta l) \stackrel{\beta \rightarrow 0}{\approx} NZ_{se} \quad (8)$$

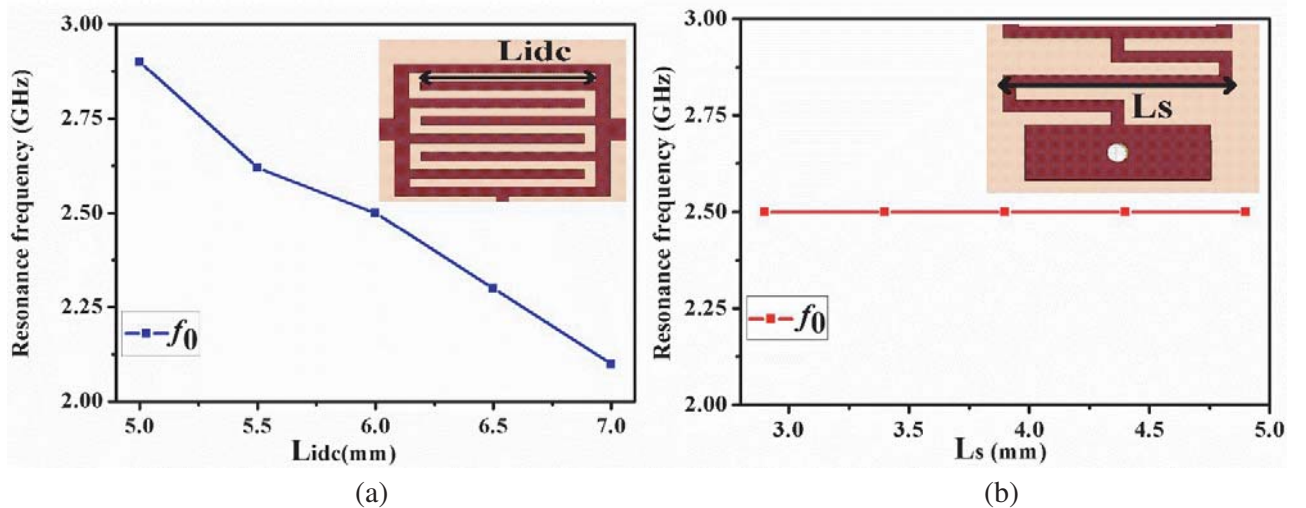

Figure 2. Resonance frequency variation with series and shunt element: (a) series element: length of interdigital capacitor ($Lidc$), (b) shunt element: length of meander line (L_s).

The resonance frequency for series parameters using Eq. (6) can be written as

$$\omega_0 = \omega_{se} = \sqrt{\frac{2L_p + L_R}{2L_p L_R C_L}} \quad (9)$$

The resonance frequency mainly depends on series parameter, and this can be verified with parametric analysis with variation of series and shunt elements, as shown in Fig. 2. In Fig. 2(a) by changing the length of the meander line (L_s), the shunt inductance (L_L) varies, but the resonance frequency remains constant. As the value of L_{dc} increases, the series capacitance C_L increases, hence resonance frequency shifts towards lower value. In Fig. 2(b), by varying the shunt parameter as length of mender line (L_s), the shunt inductance L_L varies, but the resonance frequency remains constant, and only impedance matching varies.

Hence from Fig. 2 and Eq. (9), it is concluded that the resonance frequency of designed bandpass filter is mainly controlled by series parameter due to shorted structure. The metamaterial properties, like complex permittivity (ϵ) and permeability (μ), can be evaluated using scattering parameters of D-CRLH resonator by the help of refractive index (η) and Bloch impedance (Z_B), which is calculated

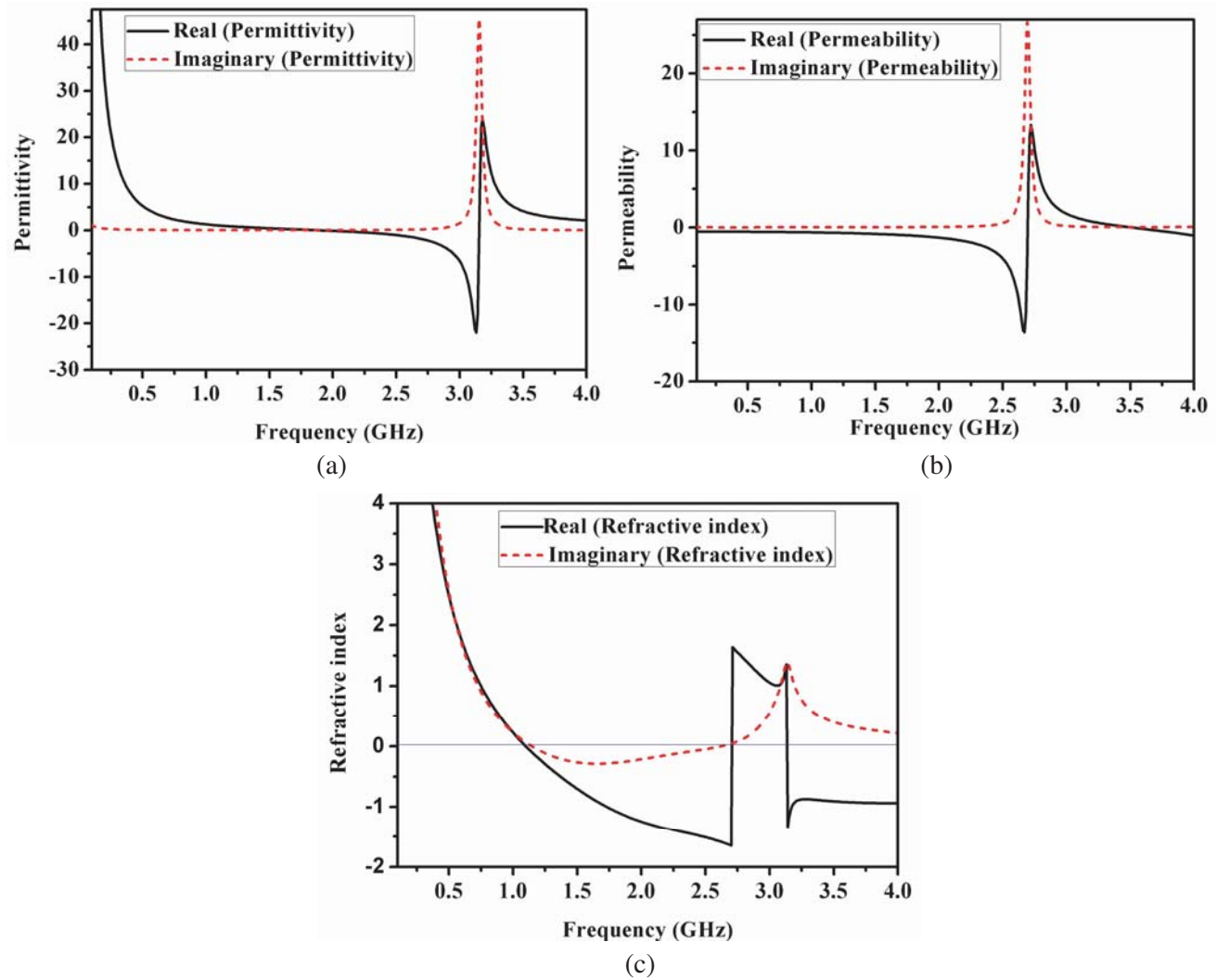

Figure 3. Extracted simulated curves of (a) complex values of permittivity (ϵ), (b) complex values of permeability (μ), and (c) complex values of refractive index (n).

using scattering parameters value of D-CRLH resonator [23, 24].

$$\epsilon = \frac{\eta}{Z_B} \tag{10}$$

$$\mu = \eta * Z_B \tag{11}$$

$$Z_B = \pm \sqrt{\frac{(1 + S_{11})^2 - S_{21}^2}{(1 - S_{11})^2 - S_{21}^2}} \tag{12}$$

$$\eta = \frac{-i}{kp} \ln \left(\frac{S_{21} \frac{Z_B - 1}{Z_B + 1}}{1 - S_{11}} \right) \tag{13}$$

where k is the wave number, p the number of unit cell, and S_{11} and S_{21} are the scattering parameters. The complex values of permittivity (ϵ), permeability (μ), and index of refraction (n) of designed metamaterial D-CRLH resonator are illustrated in Fig. 3. Fig. 3(a) simplifies that the negative real value of permittivity occurs in passband, and the highest peak is at 3.1 GHz. Meanwhile, Fig. 3(b) shows the negative real value of permeability at frequency 2.7 GHz and a positive imaginary value of it. Further, Fig. 3(c) shows the negative real value of refractive index within the passband and the highest peaks are at 2.7 and 3.1 GHz. Due to negative permeability and permittivity, a deep stopband is introduced around a resonance frequency.

3. FILTERING POWER DIVIDER

Initially, a Wilkinson power divider has been designed using two QW-TLs and an isolation resistor with values of Z_0 and $\sqrt{2}Z_0$, respectively, where Z_0 is the characteristic impedance of feedline. The symbolic diagram of the Wilkinson power divider and designed filtering power divider (FPD) are illustrated in Fig. 4. In FPD, the QW-TL of a power divider is interchanged with a D-CRLH resonator behaving as band pass response. The proposed filtering power divider is designed by replacing the QW-TL of a Wilkinson power divider by proposed D-CRLH resonator using a common rectangular stub and via. Its geometrical configuration and lumped circuit model are depicted in Fig. 5. For getting good selectivity, a surface mount 1020 ERJB1 series chip resistor of 100 ohm is connected between output ports.

The extracted lumped values of circuit model using ADS circuit simulator are: $L_p = 3.8$ nH, $L_{p1} = 3.8$ nH, $L_R = 372$ nH, $L_{L1} = 24$ nH, $L_{L2} = 69$ nH, $C_L = 2.5$ pF, $C_R = 0.56$ pF, and $C_s = 0.03$ pF, $R = 100 \Omega$. The proposed FPD is printed on an FR4 epoxy glass substrate with the value of dielectric

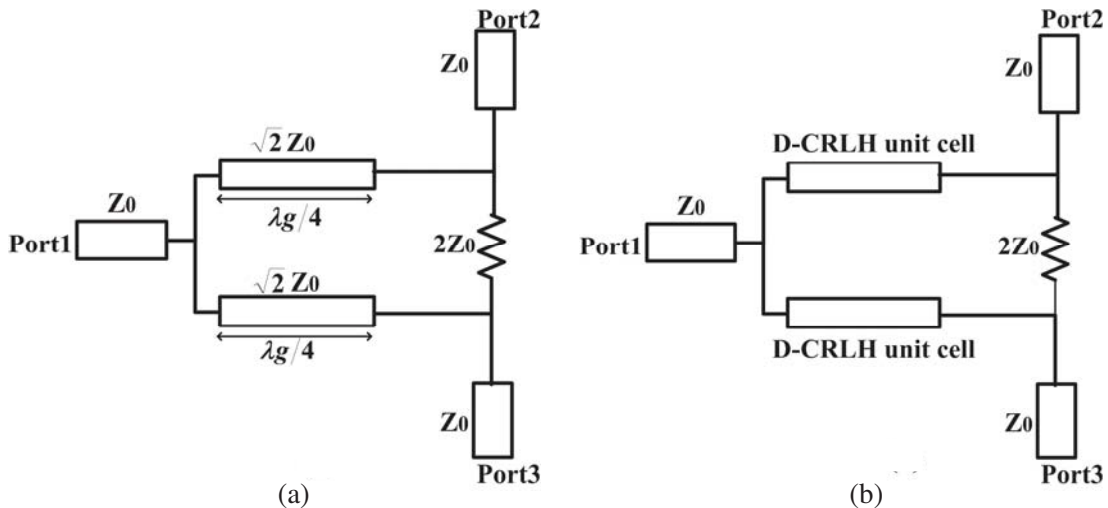

Figure 4. Symbolic diagram of (a) Wilkinson power divider, (b) proposed filtering power divider.

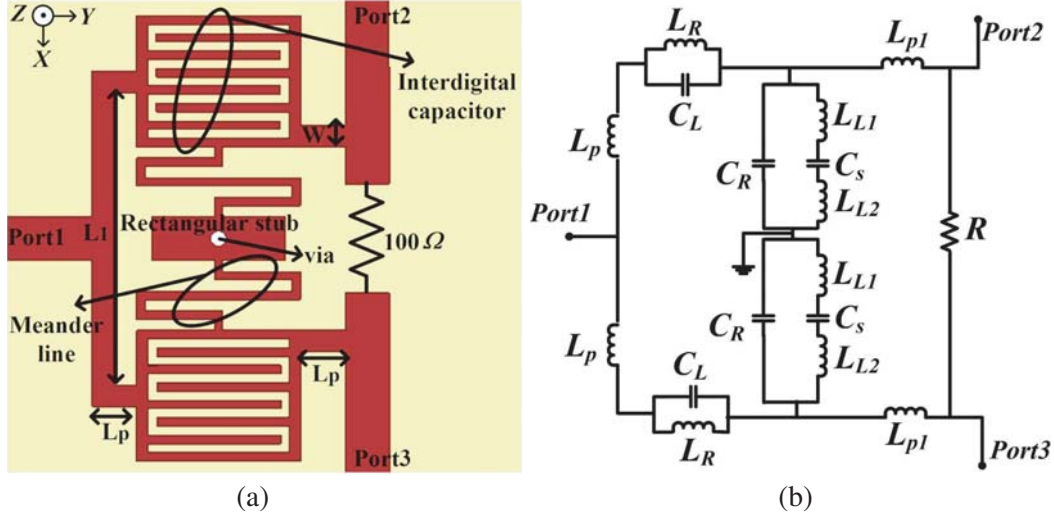

Figure 5. Designed filtering power divider. (a) Geometric configuration [The optimized structure parameters are: $L1 = 13.5$, $W = 1.0$, $Lp = 2.0$ (all units are in mm)], and (b) equivalent circuit diagram.

constant 4.4 and substrate thickness of 1.6 mm. Here the total quarter wavelength transmission line length of Wilkinson power divider is replaced by the proposed D-CRLH filter (as shown in Fig. 1(a)). Therefore, the total size reduction of the FPD power divider achieves more than 60% compared to the designed conventional power divider.

The design procedure for the proposed structure is summarized as: (i) Select the resonance frequency and design the Wilkinson power divider using a QW-TL by choosing substrate thickness and dielectric constant. (ii) Design a bandpass filter using same specifications like resonance frequency, reflection coefficient, transmission characteristics, and characteristic impedance. Draw equivalent lumped circuit model for D-CRLH structure and obtain lumped parameter using circuit simulator with some optimization. Calculate structural parameters of D-CRLH structure using an IDC, a meander line, a stub, and a via with dimensions by well-known formulas from lumped values. (iii) Replace the QW-TL of power divider with a BPF to design an FPD. A resistor is used to improve isolation.

4. RESULTS AND DISCUSSION

The fabricated prototype for the designed filtering power divider is presented in Fig. 6(a), and the dependency of resonance frequency along with transmission zero due to the change in length of IDC

Table 1. Comparison of performance of proposed filtering power divider with earlier published work.

Ref.	Electrical size ($\lambda g \times \lambda g$)	Resonance Frequency (GHz)	FBW (%) at 15 dB isolation	Return loss (dB)	Insertion loss (dB)	Isolation (dB)
This work	0.15×0.27	2.5	24.5	25	3.5	> 15.0
[8]	0.40×0.40	2.24	32.1	15.7	3.45	22.5
[11]	0.29×0.40	3.0	70	17.0	3.34	16.7
[12]	0.52×0.26	2.0	80	24	3.4	25
[15]	0.16×0.55	1.1	50	28	6.1	12
[19]	-	2.3	31	10	4.3	17

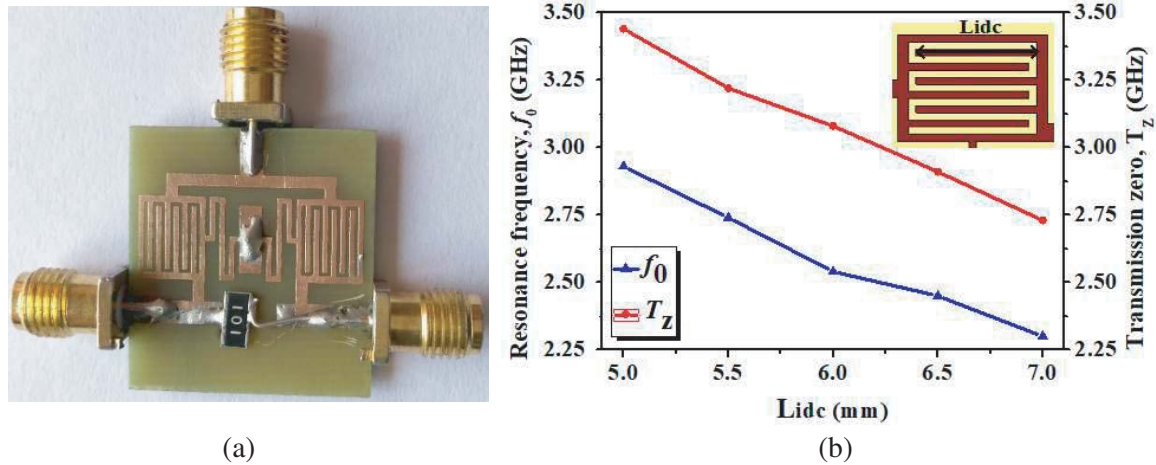

Figure 6. Proposed filtering power divider. (a) Fabricated prototype, and (b) dependency of resonance frequency and transmission zero due to series parameter.

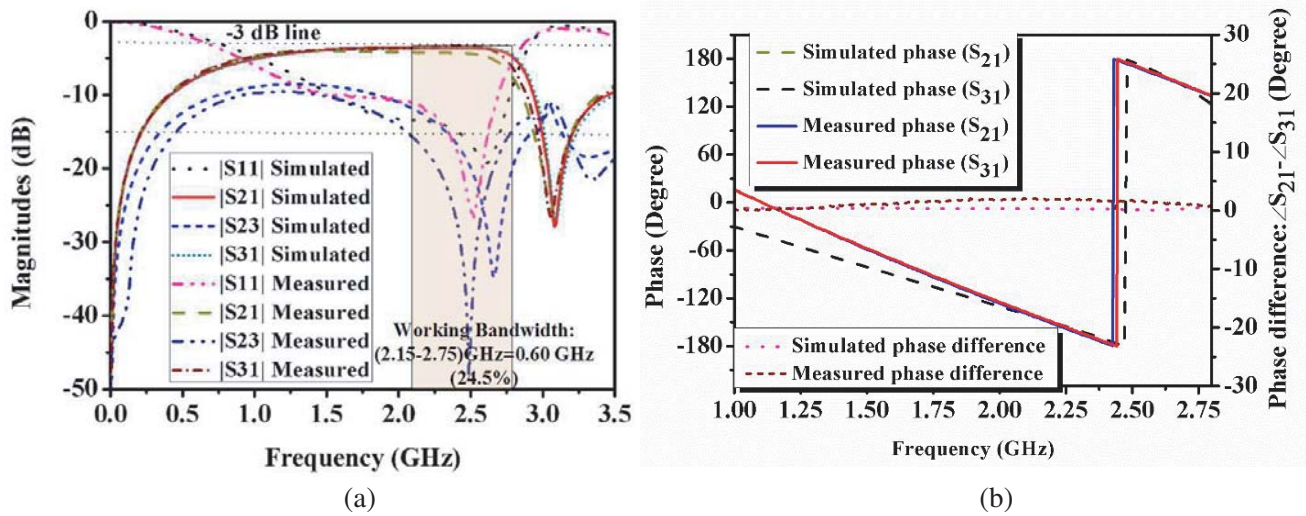

Figure 7. Measured and simulated (a) scattering parameters, and (b) phase and phase difference of filtering power divider.

is depicted in Fig. 6(b). As IDC length increases, series capacitance C_L increases, and the resonance frequency shifts towards lower value along with transmission zero. Hence, the resonance frequency and transmission zero are independently adjusted by varying the series element without disturbing its response due to short ended boundary condition. This is due to D-CRLH structure.

The designed FPD is measured by Agilent PNA (N5221A). The simulated and measured scattering parameters along with their phase difference are depicted in Fig. 7. Experimental insertion loss value is 3.5 dB within passband and transmission zero at 3.1 GHz. Experimental fractional bandwidth at isolation ($|S_{23}|$) of 15 dB is 24.5%, and the isolation at resonance frequency of 2.5 GHz is 48 dB. The measured phase difference is $0.85^\circ \pm 0.70^\circ$ among feedlines, whereas simulated difference of phase is $0.53^\circ \pm 0.10^\circ$.

The 10-dB impedance bandwidth of designed filtering power divider is 0.80 GHz (2.7 GHz–1.9 GHz), and the percentage of impedance bandwidth is 32.0% with resonance frequency of 2.5 GHz. There is a slight acceptable difference between experimental and simulated results because of fabrication and soldering errors. Table 1 compares the proposed FPD with pervious published papers in terms of size, resonance frequency (f_0), fractional bandwidth (FBW) at 15 dB isolation, insertion loss, and isolation at

resonance frequency. It indicates that the designed structure has miniaturized size, minimum insertion loss, and good isolation at resonance frequency compared to others.

5. CONCLUSION

This paper presents the design of a compact metamaterial D-CRLH unit cell and its implementation in a filtering power divider with better isolation. The proposed structure replaces the power divider's transmission line of quarter wavelength by designed D-CRLH unit cells. Resonance frequency and transmission zero are adjusted by changing the series parameter as the length of interdigital capacitor due to short circuited structure. It provides a fractional bandwidth of 24.5% at 15.0 dB isolation within working band (2.15–2.75 GHz) with minimum insertion loss. It provides maximum isolation 48.0 dB at resonance frequency. The designed structure may be appropriately utilized for GSM, Wi-MAX, and LTE applications.

REFERENCES

1. Caloz, C. and T. Itoh, *Electromagnetic Metamaterials: Transmission Line Theory and Microwave Applications*, Wiley, USA, 2006.
2. Choudhary, D. K. and R. K. Chaudhary, "A Compact Coplanar Waveguide (CPW)-fed zeroth-order resonant filter for bandpass applications," *Frequenz Journal of RF-Engineering and Telecommunications*, Vol. 71, 305–310, De Gruyter, 2017.
3. Ramachandran, T., M. R. I. Faruque, and M. T. Islam, "A dual band left-handed metamaterial-enabled design for satellite applications," *Results in Physics*, Vol. 16, 102942, 2020.
4. Choudhary, D. K., M. A. Abdalla, and R. K. Chaudhary, "Compact D-CRLH resonator for low pass filter with wide rejection band, high roll-off and transmission zeros," *International Journal of Microwave and Wireless Technologies*, Vol. 11, Nos. 5–6, 509–516, Cambridge Press, 2019.
5. Caloz, C. and N. V. Nguyen, "Novel broadband Conventional and Dual-Composite Right/Left-handed (C/D-CRLH) metamaterials: Properties, implementation and double-band coupler application," *Applied Physics A*, Vol. 87, 309–316, 2007.
6. Song, K., "Compact filtering power divider with high frequency selectivity and wide stopband using embedded dual-mode resonator," *Electronics Letters*, Vol. 51, 495–497, 2015.
7. Moradi, E., A. R. Mozenbi, K. Afrooza, and M. Movahhedi, "Gysel power divider with efficient second and third harmonic suppression using one resistor," *International Journal of Electronics and Communications (AEU)*, Vol. 89, 116–122, 2018.
8. Wang, X., J. Wang, and G. Zhang, "Design of wideband filtering power divider with high selectivity and good isolation," *Electronics Letters*, Vol. 52, 1389–1391, 2016.
9. Chau, W. M., K. W. Hsu, and W. H. Tu, "Filter-based Wilkinson power divider," *IEEE Microwave and Wireless Components Letters*, Vol. 24, 239–241, 2014.
10. Chen, C. F., T. Y. Huang, T. M. Shen, and R. B. Wu, "Design of miniaturized filtering power dividers for system-in-a-package," *IEEE Transactions on Components, Packaging, and Manufacturing Technology*, Vol. 3, 1663–1672, 2013.
11. Chau, W. M., K. W. Hsu, and W. H. Tu, "Wide stopband Wilkinson power divider with bandpass response," *Electronics Letters*, Vol. 51, 1950–1952, 2014.
12. Chen, C. J. and Z. C. Ho, "Design equations for a coupled-line type filtering power divider," *IEEE Microwave and Wireless Components Letters*, Vol. 27, 257–259, 2017.
13. Li, Q., Y. Zhang, and C. T. M. Wu, "High-selectivity and miniaturized filtering Wilkinson power dividers integrated with multimode resonators," *IEEE Transactions on Components, Packaging and Manufacturing Technology*, Vol. 99, 1–8, 2017.
14. Li, Y. C., Q. Xue, and X. Y. Zhang, "Single- and dual-band power dividers Integrated with bandpass Filters," *IEEE Transactions on Microwave Theory and Techniques*, Vol. 61, 69–76, 2013.

15. Chen, C. F., T. Y. Huang, T. M. Shen, and R. B. Wu, "Design of miniaturized filtering power dividers for system-in-a-package," *IEEE Transactions on Components, Packaging and Manufacturing Technology*, Vol. 3, 1663–1672, 2013.
16. Rostami, P. and S. Roshani, "A miniaturized dual band Wilkinson power divider using capacitor loaded transmission lines," *International Journal of Electronics and Communications (AEU)*, Vol. 90, 63–68, 2018.
17. Tang, C., X. Lin, Y. Fan, and K. Song, "A wideband power divider with bandpass Response," *International Journal of Microwave and Wireless Technologies*, Vol. 8, 83–90, 2016.
18. Zhang, P., X. Lin, C. Tang, Y. Jiang, and Y. Fan, "Wideband filtering power divider with deep and wide stopband," *International Journal of Microwave and Wireless Technologies*, Vol. 10, 1011–1018, 2018.
19. Daw, A. F., M. A. Abdalla, and H. M. E. Hennawy, "Dual-band divider has rejection band at 5 GHz," *Microwaves and RF Magazine*, 1–6, 2016.
20. Deng, Y., J. Wang, and J. L. Li, "Design of compact wideband filtering power divider with extended isolation and rejection bandwidth," *Electronics Letters*, Vol. 52, 1387–1389, 2016.
21. Choudhary, D. K. and R. K. Chaudhary, "A compact CPW-based dual-band filter using modified complementary splitting resonator," *International Journal of Electronics and Communications (AEU)*, Vol. 89, 110–115, 2018.
22. Eom, D., S. Kahng, B. Lee, C. Woo, and H. Lee, "Wide-band power divider miniaturized by combining CRLH ZOR bandpass filters," *Asia Pacific Microwave Conference Proceedings*, 541–543, 2012.
23. Choudhary, D. K. and R. K. Chaudhary, "Compact metamaterial inspired structure with bandpass characteristics for penta-band applications using virtual ground concept," *Microwave and Optical Technology Letters*, Vol. 61, 2628–2634, 2019.
24. Chen, X., T. M. Grzegorzczuk, B. I. Wu, J. Pacheco, and J. A. Kong, "Robust method to retrieve the constitutive effective parameters of metamaterials," *Physical Review E*, Vol. 70, 016608, 2004.
25. Bahl, I., *Lumped Elements for RF and Microwave Circuits*, Artech House, Norwood, USA, 2003.