

Impact of Functioning Parameters on the Wireless Power Transfer System Used for Electric Vehicle Charging

Siddharth Sahany¹, Sushree S. Biswal¹, Durga P. Kar¹,
Pradyumna K. Sahoo², and Satyanarayan Bhuyan^{1, *}

Abstract—The design guidelines have been proposed for achieving efficient wireless Electric Vehicle (EV) charging system under non-ideal practical scenarios. The effects of operating parameters have been investigated by addressing the fundamental hurdle to the widespread usage of magnetic resonance coupling (MRC) based wireless EV charging system. From both experimental and simulated results, it has been perceived that the power transfer efficiency (PTE) depreciates rapidly as the charging condition deviates from the ideal one. It is observed that PTE can be managed to enhance from the deteriorated value to an acceptable level through proper consideration of separation air gap of the charging coils, frequency of operation with acceptable horizontal offsets, suitable coil models, position of metallic object, and coil properties. To maintain the maximum PTE even under non-ideal scenario, an automated frequency tuning method has also been delineated. The corroborated experimental and simulated results can provide a complete strategic plan in the design of an efficient practical wireless power transfer system to be utilized for EV charging system.

1. INTRODUCTION

During this era, city governments all over the world are scrambling for low carbon city, by reducing the use of gasoline vehicles through Electric Vehicles (EVs) [1, 2]. Unlike hydrocarbon fuel powered vehicles, the electric energy required for the EVs can be drawn from a wide range of other sources such as nuclear power and renewable energy sources to mitigate energy crisis. Despite various advantages of EVs, the one biggest inconvenience in owning one is the time and effort wasted in driving them to a charging station and keeping them plugged in for several hours for a full charge. There is a solution to this problem, and it comes in the form of wireless charging, which would bring the ultimate convenience of owning an EV [3–8]. The wireless charging technology can be a partial and accepted solution for the upcoming era (low carbon city mission), although the efficiency is comparatively poor to classical cord charging. Instead, through the above solution, EVs can be powered up wherever they are supposed to be placed for a long time like in the office car park, garage or at the shopping centre. Therefore, the idea of magnetic resonance coupling based wireless charging for EVs is recently getting much attention from industry as well as academic groups [9–12]. Continuous effort has been made by various companies to bring out the wireless charging technology as an option for their future EVs [13, 14]. But in order to build an efficient practical wireless charging system for EVs, it is primarily required to analyze the effect of important operating parameters such as operating frequency, coil configuration, physical spacing between transmitting and receiving charging coils, horizontal offsets between the coils, position of the coils, wire property used for coil, and effect of proximal metal object on the power transfer

Received 26 September 2018, Accepted 8 February 2019, Scheduled 26 March 2019

* Corresponding author: Satyanarayan Bhuyan (satyanarayanbhuyan@soa.ac.in).

¹ Department Electronics and Communication Engineering, ITER, Siksha 'O' Anusandhan (Deemed to be University), Bhubaneswar 751030, India. ² Department Electrical Engineering, ITER, Siksha 'O' Anusandhan (Deemed to be University), Bhubaneswar 751030, India.

efficiency of the wireless charging system. A systematic study has been conducted, and the impacts of functioning parameters on wireless power transfer process have been unveiled.

2. DESIGN AND OPERATING MECHANISM OF MAGNETIC RESONANT WIRELESS CHARGING SYSTEM

The basic block diagram of the resonance based wireless EV charging system is shown in Fig. 1, and its corresponding practical setup to carry out the experimental investigation is represented in Fig. 2(a). In this WCS, the transmitting coil is directly powered by an input (RF) power source through an external series capacitor. The main objective in connecting the extra capacitor is to make the combination tuned at their resonant frequency due to which maximum exciting current will be allowed to flow through the coil at the transmitting end. Similarly, coil at the receiver placed away from the transmitting coil is excited with the same frequency of operation as the transmitting coil. At resonance, both the coils are coupled with strong magnetic fields, which enable power transfer from transmitting to receiving coils at a faster rate over an adequately larger distance. The AC output power across the receiving coil is processed before being supplied to the battery of EV. The electromagnetic simulation model of the resonance based WCS is given, and the built up model is depicted in Fig. 2(b) to analyze the performance of EV charging system. The fundamental principle impacting WPT concept is magnetic resonant inductive coupling. By the principle, two distant coils' near magnetic fields (order of their coil size), when being resonated at a particular frequency, will be strongly coupled with each other and

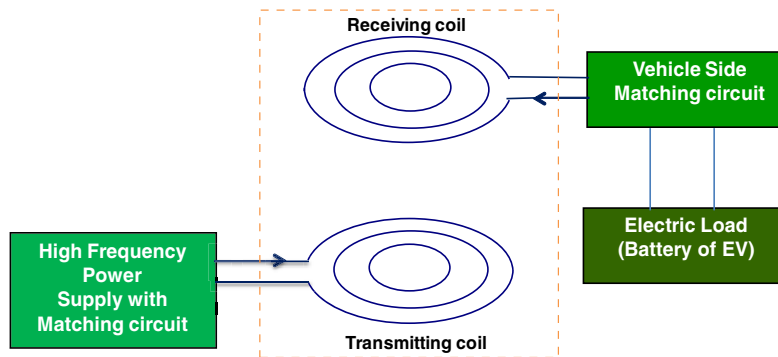

Figure 1. Block diagram of the procedure involved in the resonance based wireless power transfer system for Electric Vehicle charging.

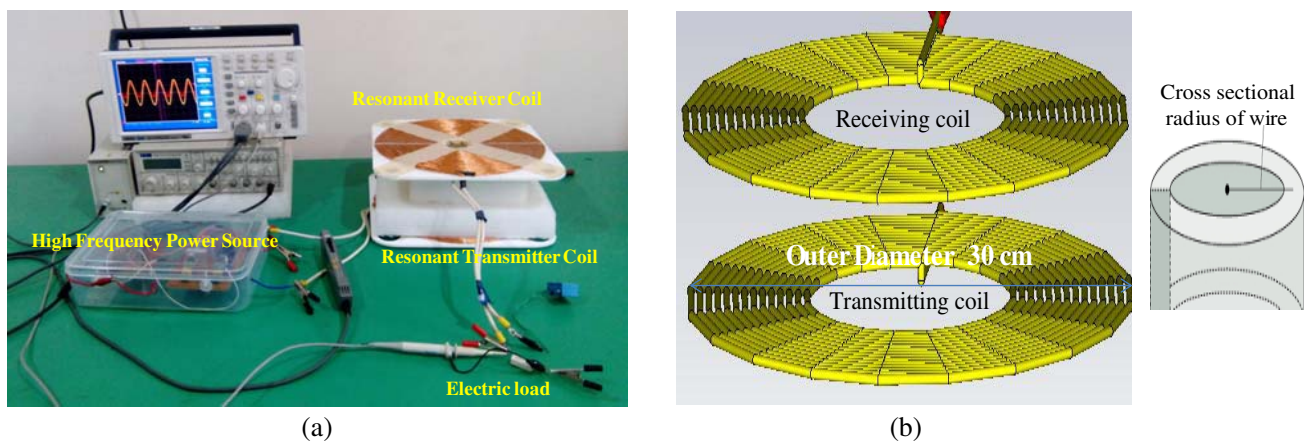

Figure 2. (a) Corresponding practical setup to carry out the experimental investigation of wireless power transfer. (b) Coil simulation model to carry out analytical study of wireless power transfer.

Table 1. Experimental as well as simulation parameters of WPT system.

Parameters	Value
Inductance of the transmitting coil (L_1)	168 μ H
Inductance of the receiving coil (L_2)	168 μ H
conductivity of the litz wire (σ)	7.096×10^7 S/m
Area of cross section of the wire (a)	3.5 mm
Radius of the coil (R)	15 cm
Number of turns (N)	18
Resonating Capacitance (C)	330 nF
Permeability of the free space (μ_o)	1.256×10^{-6} mkgA ⁻¹ s ⁻¹
velocity of light (c)	3×10^8 ms ⁻¹
permittivity of the free space (ϵ_0)	8.85×10^{-12} C ² N ⁻¹ m ⁻²

due to which energy will be transferred between the coils at a faster rate as well as efficiently. The experimental as well as simulated parameters of WPT system are given Table 1.

3. THEORETICAL ANALYSIS OF WIRELESS POWER TRANSFER EFFICIENCY

A typical strongly coupled magnetic resonance based WCS for EV is designed with an off-board transmitter coil positioned at the charging station and an on-board receiver coil embedded in the vehicle. The wireless power transfer between the coils is primarily through electromagnetic resonant coupling in this system. The frequency of resonance for both the transmitting and receiving coils of the WCS is calculated as:

$$f = \frac{1}{2\pi\sqrt{LC}} \tag{1}$$

where L is the inductance of the coil, and C is the capacitance of the externally connected capacitor. For a circular spirally configured coil of N turns, mean radius r and depth of coil (outer radius minus inner radius) d , the self-inductance L is given by [15, 16]:

$$L = \frac{r^2 N^2}{(2r + 2.8d) \times 10^5} \tag{2}$$

Here in this experiment and simulation study, both transmitting and receiving coils are circularly spiral configured and made up of the same material and dimension wise equal, and the coupling coefficient of the direct link is as follows [17]:

$$k = \frac{\pi f M}{\sqrt{L_1 L_2}} = \frac{\pi f M}{L} \tag{3}$$

where the self-inductances of the transmitting and receiving coils are L_1 and L_2 , respectively, and bound by conditions (outer radius $R_1 = R_2 = R$; inductance $L_1 = L_2 = L$). The mutual inductance of the RF link can be determined as follows [17]:

$$M_{12} = \mu_0 R \left[\left(\frac{2}{x} - x \right) K(x) - \frac{2}{x} E(x) \right] \tag{4}$$

where $x = \frac{2R}{\sqrt{4R^2 + D^2}}$.

$K(x)$ and $E(x)$ are the complete elliptic integrals of the 1st and 2nd kinds. Permeability of the free space is μ_o , and the air gap between the coils is denoted as D . For the two coils, each with a finite number of turns, the total mutual inductance can be calculated by summing up all the loop pairings

between the coils:

$$M = \sum_{i=1}^{n_1} \sum_{j=1}^{n_2} M_{ij} \quad (5)$$

As in the case of magnetic resonance based WPT system, the energy transfer between the coils occurs at a faster rate than the dissipated energy through ohmic and radiative losses, hence, maximum power transfer efficiency (η) is achieved. For the given system with ohmic resistance (R_{ohmic}) and radiative resistance ($R_{radiative}$), the intrinsic loss rate (Γ) or the resonance width due to radiative and ohmic losses will be [3]:

$$\Gamma = \frac{(R_{ohmic} + R_{radiative})}{2L} \quad (6)$$

Thus, from Equations (3)–(6), the coupling to loss ratio will be

$$\frac{k}{\Gamma} = \frac{2\pi f M}{(R_{ohmic} + R_{radiative})} \quad (7)$$

The circular spiral coil made of copper litz wire has outer radius R , total length l , cross sectional radius a , conductivity σ , and self-inductance L . With N number of turns, c is the speed of light, and ϵ_0 is the free space permittivity. The ohmic resistance (R_{ohmic}) and radiative resistance ($R_{radiative}$) of the circular spiral coil are [3]:

$$R_{ohmic} = \frac{RN}{2a} \sqrt{\frac{\mu_0 \pi f}{\sigma}} \quad (8)$$

$$R_{radiative} = \sqrt{\frac{\mu_0}{\epsilon_0}} \left[\frac{4\pi^5 N^2}{3} \left(\frac{fR}{c} \right)^4 \right] \quad (9)$$

The coupling to loss ratio (k/Γ) can be rewritten as follows:

$$\frac{k}{\Gamma} = \frac{\mu_0 \pi^2 f N R^3}{(R^2 + D^2)^{3/2}} \left[\frac{1}{\frac{1}{2a} \sqrt{\frac{\mu_0 \pi f}{\sigma}} + \sqrt{\frac{\mu_0}{\epsilon_0}} \frac{4\pi^5 N R^3}{3} \left(\frac{f}{c} \right)^4} \right] \quad (10)$$

The PTE (η) of the WPT system can be obtained as follows [3]:

$$\eta = \frac{\frac{k^2}{\Gamma^2} \sqrt{1 + \frac{k^2}{\Gamma^2}}}{\left(1 + \sqrt{1 + \frac{k^2}{\Gamma^2}} \right) \frac{k^2}{\Gamma^2} + \left(1 + \sqrt{1 + \frac{k^2}{\Gamma^2}} \right)^2} \quad (11)$$

From Equations (10) and (11), it can be seen that the PTE depends on various factors such as electromagnetic coupling coefficient, mutual inductance between the coils, separation distance between coils, coil dimension, coil material property, and operating resonant frequency.

4. RESULTS AND DISCUSSION

The frequency dependent PTE and coupling to loss ratio characteristics corresponding to different separation gaps are depicted in Fig. 3(a) and Fig. 3(b), respectively. It can be apprehended that each system will have its own optimum operating frequency regime for which maximum efficiency is achieved subsequent to larger coupling to loss ratio that is clearly supported by Equation (10). The theoretical frequency characteristic of the PTE obtained from the electromagnetic simulation model analysis is illustrated in Fig. 4(a), and it is compared with the experimental frequency characteristic of PTE depicted in Fig. 4(b). From the figure, the theoretical results are found to agree well with the experimental data that the PTE is maximum for the operating resonant frequency and gradually falls

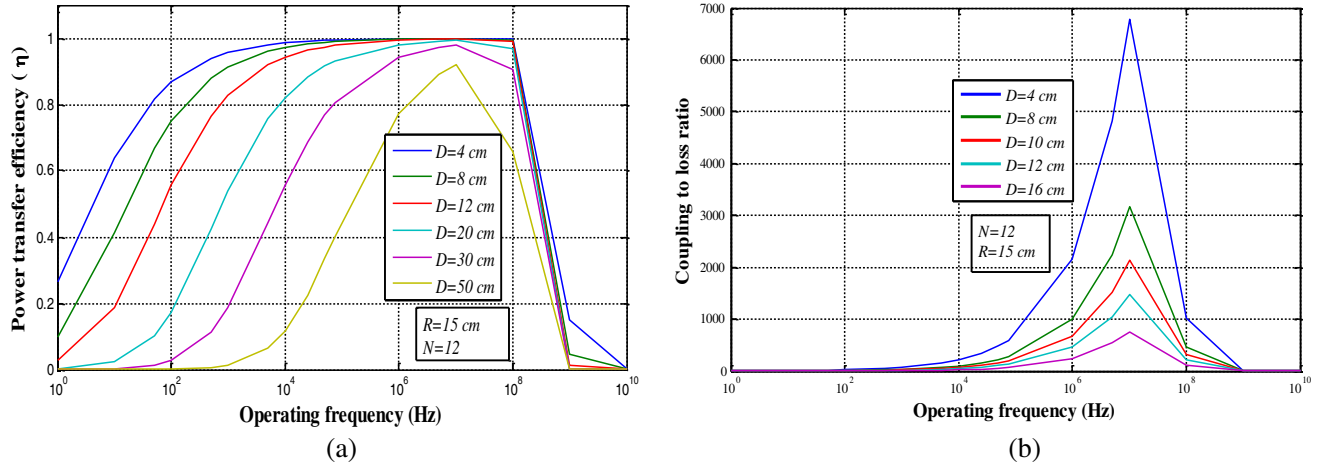

Figure 3. (a) The calculated power transfer efficiency characteristics with respect to operating frequency at different vertical separation distance. (b) Frequency characteristics of the coupling to loss ratio at different physical spacing between the coils.

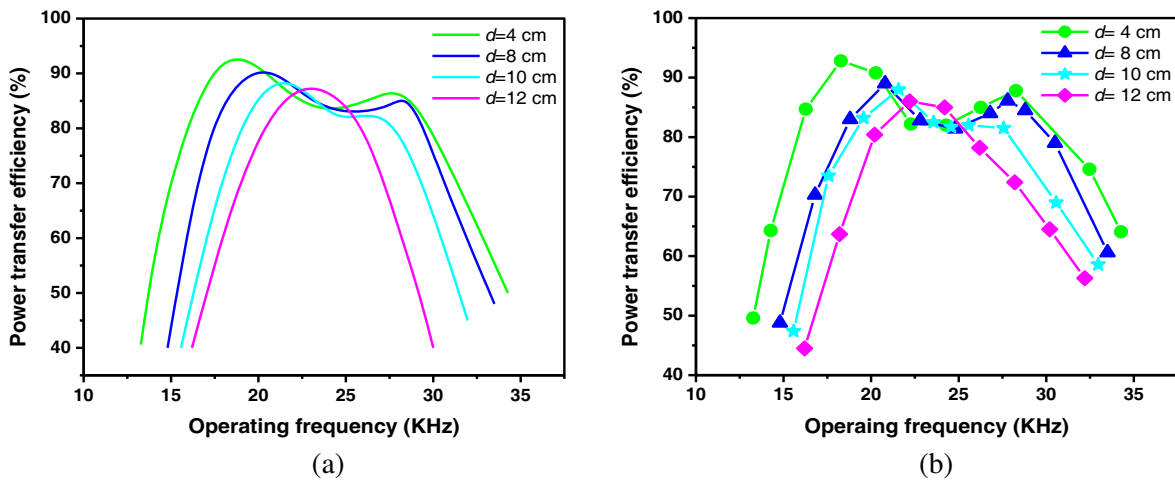

Figure 4. Frequency characteristics of wireless power transfer efficiency: (a) Theoretical. (b) Experimental.

if the system operates at frequency other than the resonant frequency. This is in general due to strong magnetic field coupling between the coils at their resonant frequency. Therefore, it is crucial to consider the strongly coupled region for each system such that maximum power transfer occurs, taking account of the resonant frequency. As a sample case, for 12 cm vertical separation distance between the coils, resonated at 22.20 kHz, the maximum PTE is 86%. Shifting the vertical separation to 10 cm, maximum PTE is 88% corresponding to a resonant frequency of 21.57 kHz. It is observed experimentally that if a fixed operating frequency, such as 22.20 kHz, is utilized for vertical separation of 10 cm efficiency of the system is reduced to 84%. In fact, this is due to the sharp drop of the mutual coupling with deviation in the physical spacing between the coils for a fixed resonant frequency. This confirms that resonant frequency varies with separation air gap between the coils, and it is also affirmed that for a specific air-gap the resonant frequency is definite for which maximum PTE can be accomplished. Therefore, coils separation distance corresponding to operating frequency needs to be considered for realizing an efficient wireless EV charging system.

Analogous to the separation distance characteristics, PTE dependency correspondence to lateral misalignment with reference to the centre of the charging coils for a fixed vertical air gap has been

experimentally investigated. The experimental results of the varied horizontal offset (0 cm to 12 cm) verses PTE corresponding to frequency variation for 12 cm fixed vertical air-gap are shown in Fig. 5. It can be seen that the PTE is reduced for larger offsets between the coils. From the results, it is also seen that if the resonant frequency 22.20 kHz for fixed vertical distance of 12 cm with null (0 cm) offset is referenced, then PTE decreases drastically with variation in horizontal offset between the coils for the same operating frequency. So, it is essential to tune the frequency to the desired resonant frequency to maintain maximum PTE for distinct horizontal offsets between the coils.

In order to realize an efficient wireless power transfer, the electromagnetic simulation has been carried out for different system models such as two-coil system, three-coil system, and four coil system. The WPT system model is shown in Fig. 6. The two-coil system consists of transmitting resonant coil and receiving resonant coil. The three-coil model consists of driving coil, transmitting resonant coil, and receiving resonant coil whereas the four-coil system comprises driving coil, resonantly linked transmitter and receiver coils, and load coil. In all three kinds of coil models, the receiving coil and the distant transmitting coil are well tuned and strongly coupled with each other. The driving coil is inductively

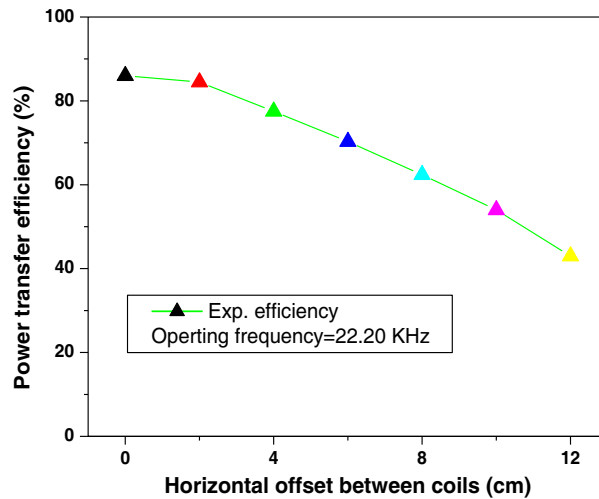

Figure 5. Effect of the horizontal offsets between the centres of charging coils for a certain vertical distance on the power transfer efficiency.

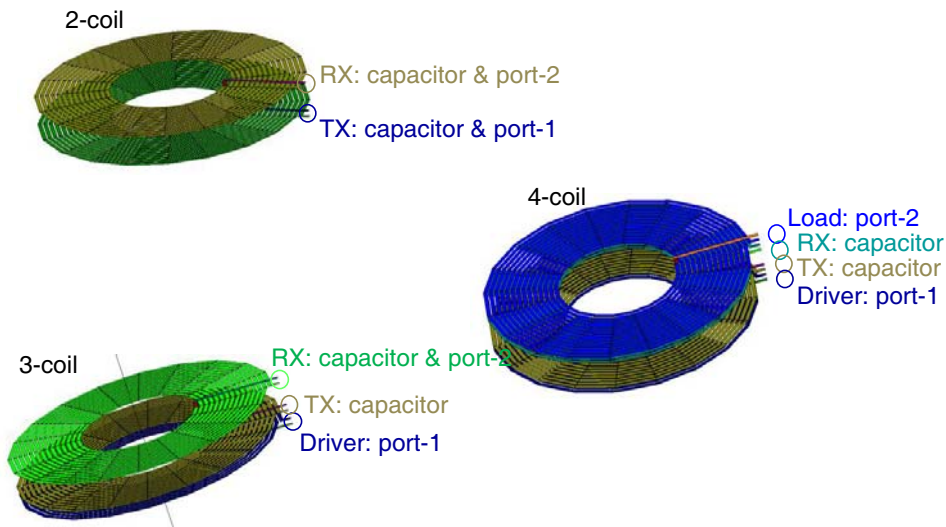

Figure 6. Electromagnetic simulation models of different wireless power transfer systems depending on coil arrangements such as two coil system, three coil system and four coil system.

coupled with the transmitting coil at a separation distance of 1 cm in the three-coil model. In the four-coil model, driving coil and transmitting resonant coil pair are inductively coupled with each other at a separation distance of 1 cm. Similarly, the load coil and receiving resonant coil pair are inductively coupled with each other at a separation distance of 1 cm. The frequency characteristics of PTE for the two-coil, three-coil and four-coil systems with vertical separation distances of 12 cm and 20 cm are shown in Figs. 7(a) and (b). It is certain that the PTE of the four-coil system is relatively higher than the other two coil models for larger air spacing between the charging coils. However for smaller air gap, the variation is almost insignificant. Hence it is important to consider a suitable coil model with respect to the physical spacing between the charging coils to develop an efficient WPT system for EV charging.

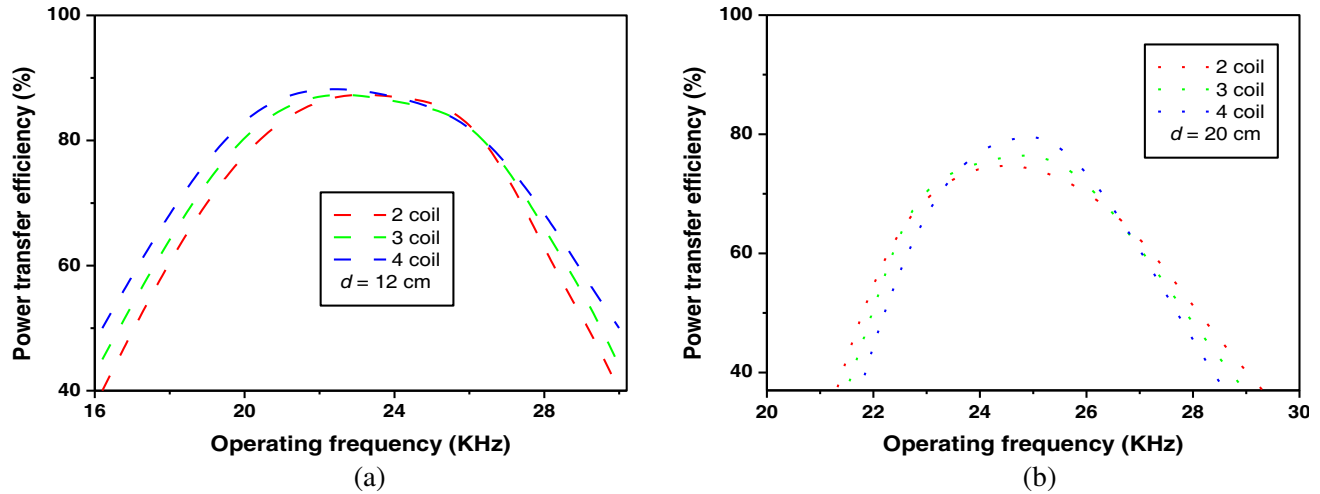

Figure 7. (a) Frequency characteristics of power transfer efficiency of the two coil, three coil and four coil systems: (b) for vertical distance of 12 cm (c) for vertical distance of 20 cm.

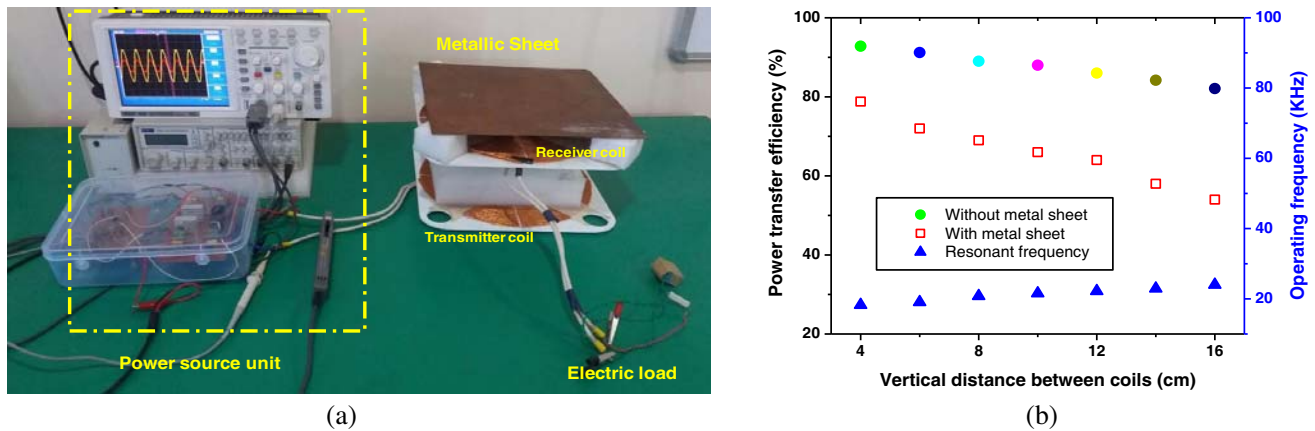

Figure 8. (a) Schematic diagram of resonant wireless power transfer system with proximal metallic object. (b) Measured frequency characteristics of optimum power transfer efficiency with different vertical spacing between the coils in the presence of metallic sheet.

As the EVs are mounted with metallic objects, the proximal metal effect on the power transfer enactment of the WCS cannot be ignored. Hence, wireless PTE dependencies on the surrounding metallic object of the WPT system are investigated. In the experiment, a metal copper sheet of ($35 \times 35 \text{ cm}^2$) positioned 5 cm away from the WPT system is used to observe its effect on the PTE, as shown in Fig. 8(a). From the result it is confirmed that PTE of the WPT system drastically decreases

in the presence of surrounding metallic objects and resultantly reduces the mutual inductance between the charging coils. Another important thing observed is variation of the operating resonant frequency, which is not only due to the change in physical spacing but also due to the proximity of metallic objects. It is examined that when the vertical spacing is maintained at 12 cm between the charging coils, a metal sheet is retained 5 cm away from the receiving coil, fully tuned at 22.20 kHz, and the efficiency decreases from 86% to 64%. This is represented in Fig. 8(b). However, PTE can be enhanced from 64% to 75% by tuning the operating frequency from its initial value 22.20 kHz to 23.10 kHz. Thus it is suggested that to maintain maximum PTE, the presence of metal objects nearer to EVs has to be carefully considered.

To outline the effect of material used for coil winding, parallel experiment has been carried out with same spiral structured coils made up of copper conductor instead of Litz wire, shown in Fig. 9. It is observed that a relatively higher PTE of 86% is achieved through Litz wire coil than 79% acquired through normal Copper wire coil. The cause of enhancement in the power transfer efficiency is small A.C. resistance of the Litz wire which in turn provides high quality factor and better coupling coefficient.

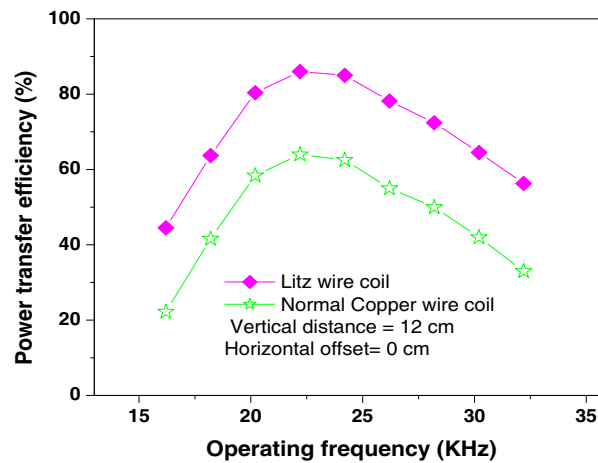

Figure 9. The frequency characteristic of power transfer efficiency by using Litz wire coil and normal Copper wire coil.

From the above analysis, it is clearly observed that sensitivity of the wireless EV charging system is affected by the operating frequency, proximity to metallic objects, and relative position of charging coils. If operating resonant frequency is fixed, the PTE of the WCS decreases drastically with the horizontal offsets and also with the presence of nearby metal sheet. But by permitting the operating frequency to adapt with the proximal metallic objects and physical spacing between the coils through an automated frequency tuning scheme the deteriorated PTE can be further enhanced.

The illustrated block diagram in Fig. 10 presents the automatic frequency tuning scheme for resonant wireless EV charging system. In order to evaluate the PTE, the voltage and current values at the input of the transmitting coil are screened. The sensed current value through the current probe is converted to its equivalent voltage level by a current to voltage converter and further feed to an Analogue to Digital Converter after scaling within its dynamic range. The field programming Gate Array (FPGA) processes the output signal of Analog to Digital Converter and continuously screens the difference in phase of both the signals. The system will continuously check the phase difference between the input current and voltage signals. If any phase deficit exists between the signals, the frequency tuning system will tune the frequency till the two signals are in phase.

The proposed automatic frequency tuning system is capable of tuning the operating frequency to its correct value so as to achieve maximum PTE for different vertical separation distances. The PTE characteristics with respect to unique vertical separation distance corresponding to resonant frequencies are illustrated in Fig. 11(a). From both simulated and experimental results it is established that resonance frequency varies with variation in separation air-gap between the coils. The PTE is found to be 86% for a coil separation air-gap of 12 cm at its corresponding resonant frequency 22.20 kHz, while

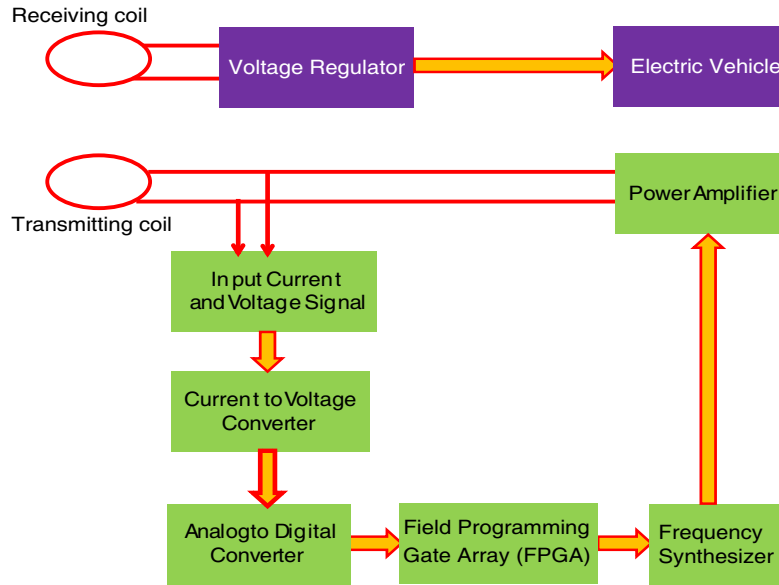

Figure 10. Process involved in automatic frequency tuned resonant wireless charging system.

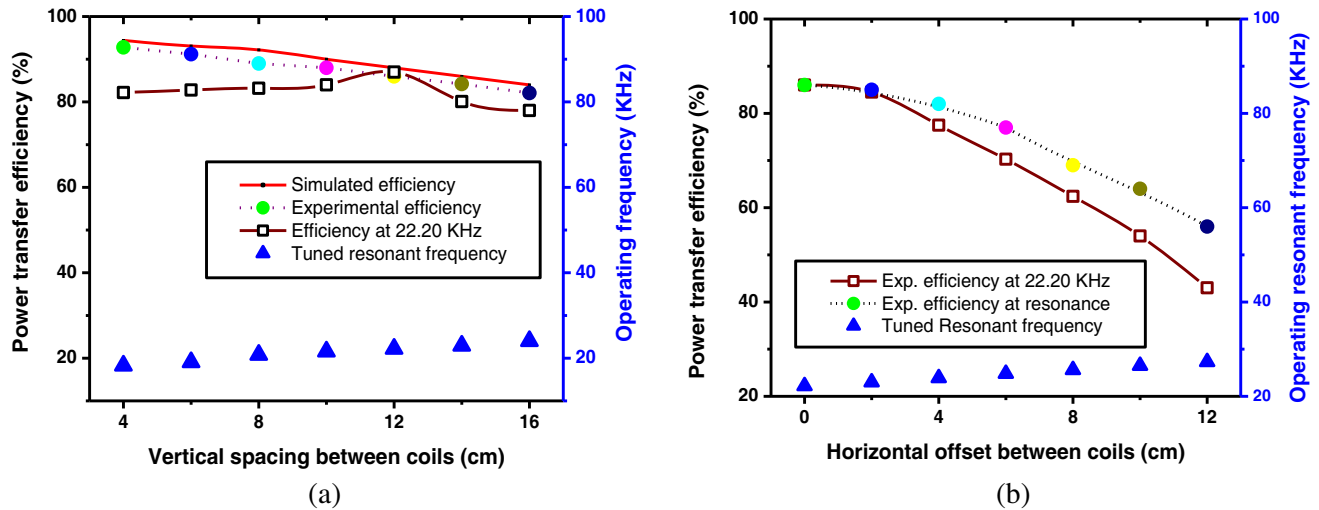

Figure 11. (a) Frequency characteristics of power transfer efficiency for different vertical distance between the charging coils. (b) Effect of the horizontal offsets between the centres of charging coils for a certain vertical distance on the power transfer efficiency.

at the same frequency of operation at 10 cm vertical spacing the PTE is reduced to 70.16%. But again by retuning the frequency to 25.10 kHz for the same 10 cm vertical spacing, the power transfer efficiency is considerably improved from 70.16% to 77.68% through the proposed automated frequency tuning scheme. Hence it is affirmed that the proposed automatic frequency tuning scheme is able to maintain an acceptable power transfer rate under non-ideal wireless EV charging scenario having different ground clearances.

Similarly, the proposed automatic frequency tuning system can considerably improve the PTE even for horizontal offset between the coils. The PTE characteristics corresponding to their resonant frequency with horizontal offsets are shown in Fig. 11(b). It can be observed that the PTE is 86% for a fixed vertical distance of 12 cm with no offset (0 cm offset) and the corresponding resonant frequency 22.20 kHz. For a horizontal offset of 6 cm, the PTE is reduced to 70.16% for the fixed operating

frequency 22.20 kHz. But by tuning the frequency to its resonating frequency 25.10 kHz, the power transfer efficiency is considerably improved from 70.16% to 77.68% through the proposed automatic frequency tuning system. Hence the proposed automatic frequency tuning system is able to mitigate the misalignment effect between the coils leading to maximum power transfer efficiency under non-ideal practical EV charging conditions.

5. CONCLUSIONS

The presented work analyzes PTE of wireless EV charging system influenced by different operating design parameters and is demonstrated through electromagnetic simulations as well as experimental measurements. The electromagnetic simulation results are found to agree well with experimental findings. The observation data and experimental finding articulate the fact that PTE of a magnetic resonance based wireless EV charging system is severely affected by design operands like frequency of operation, coils alignment, proximal metallic objects, and coil configuration. The PTE attains its peak only when the operating frequency is matched to the resonant frequency but diminishes with increase in coil separation distance, horizontal offsets, and presence of proximal metal objects. The WPT system is seen to be efficient strictly in strong coupling regime that abides by the condition of very high value of coupling to loss ratio. The operating resonant frequency is seen to be varied with coil model, vertical separation distance, horizontal offset, and nearby metal sheet. Experimentally it is asserted that the PTE can be enhanced by changing the design parameters. The analysis marks the design strategy to realize a practical WPT system for EV considering various operating parameters like operating resonant frequency, suitable coil model, optimum coils separation distance, distant metallic object, and coil made of wire having low A.C. resistance.

ACKNOWLEDGMENT

This work supported by Science and Engineering Research Board, DST, Government of India (Project Grant Number: SB/FTP/ETA-135/2014).

REFERENCES

1. Ma, H., F. Balthasar, N. Tait, X. Riera-Palou, and A. Harrison, "A new comparison between the life cycle greenhouse gas emissions of battery electric vehicles and internal combustion vehicles," *Energy Policy*, Vol. 44, 160–173, 2012.
2. Bowermaster, D., M. Alexander, and M. Duvall, "The need for charging: Evaluating utility infrastructures for electric vehicles while providing customer support," *IEEE Electrification Magazine*, Vol. 5, No. 1, 59–67, 2017.
3. Kurs, A., A. Karalis, R. Moffatt, J. D. Joannopoulos, P. Fisher, and M. Soljacic, "Wireless power transfer via strongly coupled magnetic resonances," *Science*, Vol. 317, 83–86, 2007.
4. Musavi, F. and W. Eberle, "Overview of wireless power transfer technologies for electric vehicle battery charging," *IET Power Electronics*, Vol. 7, No. 3, 60–66, 2014.
5. Kar, D. P., P. P. Nayak, S. Bhuyan, and S. K. Panda, "Study of resonance based wireless electric vehicle charging system in close proximity to metallic objects," *Progress In Electromagnetic Research M*, Vol. 37, 183–189, 2014.
6. Lukic, S. and Z. Pantic, "Cutting the cord: Static and dynamic inductive wireless charging of electric vehicles," *IEEE Electrification Magazine*, Vol. 1, No. 1, 57–64, 2013.
7. Choi, J. and C. Seo, "Analysis on transmission efficiency of wireless energy transmission resonator based on magnetic resonance," *Progress In Electromagnetics Research M*, Vol. 19, 221–237, 2011.
8. Kar, D. P., P. P. Nayak, S. Bhuyan, and S. K. Panda, "Automatic frequency tuning wireless charging system for enhancement of efficiency," *Electronics Letters*, Vol. 50, No. 24, 1868–1870, 2014.
9. Choi, J. and C. Seo, "Analysis on transmission efficiency of wireless energy transmission resonator based on magnetic resonance," *Progress In Electromagnetics Research M*, Vol. 19, 221–237, 2011.

10. Wei, X. C., E. P. Li, Y. L. Guan, and Y. H. Chong, "Simulation and experimental comparison of different coupling mechanisms for the wireless electricity transfer," *Journal of Electromagnetic Waves and Applications*, Vol. 23, No. 7, 925–934, 2009.
11. Samal, S. K., D. P. Kar, P. K. Sahoo, S. Bhuyan, and S. N. Das, "Analysis of the effect of design parameters on the power transfer efficiency of resonant inductive coupling based wireless EV charging system," *2017 Innovations in Power and Advanced Computing Technologies (i-PACT)*, 1–4, 2017.
12. Kar, D. P., S. S. Biswal, P. K. Sahoo, P. P. Nayak, and S. Bhuyan, "Selection of maximum power transfer region for resonant inductively coupled wireless charging system," *International Journal of Electronics and Communications*, Vol. 84, 84–92, 2016.
13. Covic, G. A., J. T. Boys, M. L. G. Kissin, and H. G. Lu, "A three-phase inductive power transfer system for roadway-powered vehicles," *IEEE Trans. Ind. Electron.*, Vol. 54, No. 6, 3370–3378, 2007.
14. Young, D. K. and Y. J. Jang, "The optimal design of the online Electric Vehicle utilizing wireless power transmission technology," *IEEE Trans. Intelligent Transportation Systems*, Vol. 14, No. 3, 1255–1265, 2013.
15. Wheeler, H. A., "Simple inductance formulas for radio coils," *Proc. IRE*, Vol. 16, No. 10, 1398–1400, 1928.
16. Grover, F. W., *Inductance Calculations: Working Formulas and Tables*, Dover Publication, Inc., New York, 1946.
17. RamRakhyani, A. K., S. Mirabbasi, and C. Mu, "Design and optimization of resonance-based efficient wireless power delivery systems for biomedical implants," *IEEE Trans. on Biomedical Circuits and Systems*, Vol. 5, No. 1, 48–63, 2010.