

A Compact-Integrated Reconfigurable Rectenna Array for RF Power Harvesting with a Practical Physical Structure

Euclides L. Chuma^{1, *}, Yuzo Iano¹, Mathias S. Costa¹,
Leandro T. Manera¹, and Leonardo L. Bravo Roger²

Abstract—This paper presents the design of a compact-integrated reconfigurable rectenna array containing 2×2 compact microstrip patch antennas based on a fractal model with the rectifier circuit integrated into the same physical structure and usable in practical conditions. In this array configuration, four rectennas were mounted in a planar structure with total dimensions of 85×85 mm using FR-4 dielectric and with reconfigurable DC output that was tested in three ways: series-association, parallel-association and series-parallel association. In the series-association the rectenna array was able to generate the DC power that reached 6.51 V and maximum efficiency of 64.5%; in the parallel-association it generated the DC power that reached 1.58 V and maximum efficiency of 65.3%; in series-parallel-association it generated the DC power that reached 3.00 V and maximum efficiency of 64.5%. The results showed that rectennas in array configuration are feasible to be used as power supplies to electronic devices in real situations.

1. INTRODUCTION

The concept of rectenna was introduced in the 1960s [1] when an antenna and a rectifier circuit were combined to harvest microwave electromagnetic energy and convert it to DC power.

Nowadays rectennas [2–6] have taken a lot of attention due to the increasing interest in alternative power supplies to IoT (Internet of Things) devices because it is a convenient and eco-friendly way to substitute conventional batteries powering wireless devices since unlike batteries, it does not need to be periodically replaced and polluting the environment.

This article proposes a compact-integrated and reconfigurable rectenna array of 2×2 with total dimensions of $85 \text{ mm} \times 85 \text{ mm} \times 2.5 \text{ mm}$ and resonance frequency of 2.45 GHz (ISM band). The array was based on the previously developed rectennas [7] which are compact with good efficiency by area. Therefore, the association of rectennas in a reconfigurable array makes this project useful in real situations.

2. RECTENNAS AND ARRAY CONFIGURATIONS

The operating principle of a rectenna consists in harvesting the electromagnetic energy by an antenna and goes through a low-pass filter and impedance matching circuit and then transfers to a rectifier diode which is converted into DC electricity. The parts of a rectenna are shown in the block diagram of Fig. 1 [8].

Received 25 March 2018, Accepted 24 June 2018, Scheduled 6 July 2018

* Corresponding author: Euclides L. Chuma (euclides.chuma@ieee.org).

¹ School of Electrical and Computer Engineering, University of Campinas-UNICAMP, Brazil. ² School of Technology, University of Campinas-UNICAMP, Brazil.

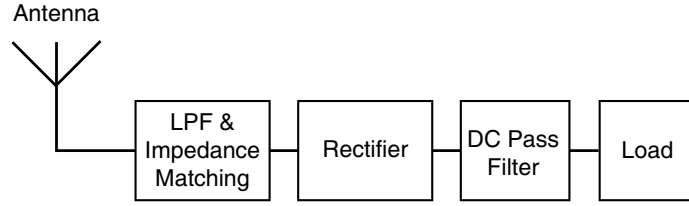

Figure 1. Parts of a rectenna.

The design of rectenna typically aims to maximize the power transfer to the load and consequently, the RF to DC conversion [9]. To achieve this goal, a proper impedance matching network between antenna and rectifier circuit is necessary, which presents a nonlinear behavior because of the diodes.

In most cases, a single rectenna is not sufficient to supply energy for device operation, and then grouping several antennas in an array is necessary. There are two approaches to combine the rectennas in an array, and each configuration has advantages and disadvantages [10].

In one configuration, each rectenna of an array is composed by an antenna that incorporates its own rectifier to separately harvest DC power [11], combined in a series and/or parallel configuration as can be seen in Fig. 2(a). In another configuration, multiple antennas can be arranged for a single rectifier [12] as can be seen in Fig. 2(b).

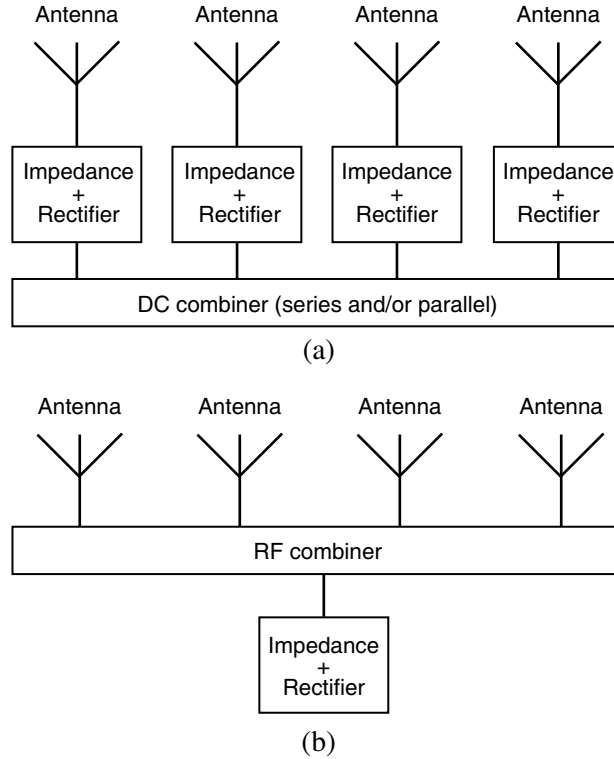

Figure 2. Schematics of the configurations to rectenna array.

In this work, we design a compact rectenna array with 2×2 rectennas using the configuration where each rectenna has its own antenna and rectifier. The rectennas were combined in three configurations: series-association, parallel-association and series-parallel-association, and thereby it was possible to analyze the performance of rectennas in array configuration combining the outputs of the rectifiers of the rectennas.

3. RECTENNA DESIGN

3.1. Antenna

The previous work [7] was the start point for the antenna design using microstrip patch with a miniaturization technique based on Koch curve fractal geometry that makes possible to have a large electric length in a small physical volume [13].

To design the antenna, a low-cost dielectric substrate FR-4 ($\epsilon_r = 4.2$ and $\tan\delta = 0.02$) with a thickness of 2.5 mm was used. The thickness of 2.5 mm was used instead of the conventional 1.6 mm to compensate part of the gain reduction caused by the fractal geometry. The final geometry of the patch with dimensions can be seen in Fig. 3.

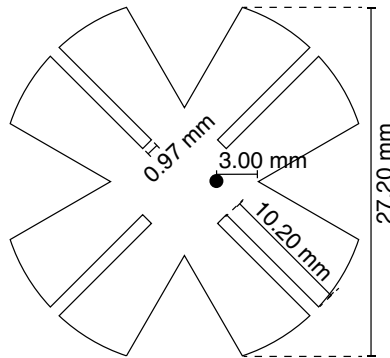

Figure 3. Geometry of patch with dimensions.

The simulation of the antenna was performed by using the full wave simulator Ansys HFSS, and the simulated and measured S_{11} can be seen in Fig. 4. The simulated and measured antenna realized gains (including mismatch losses) are 0.19 dB and 0.61 dB. In order, the simulations and measured results presented until here are to one only antenna, and the array configuration is shown further on.

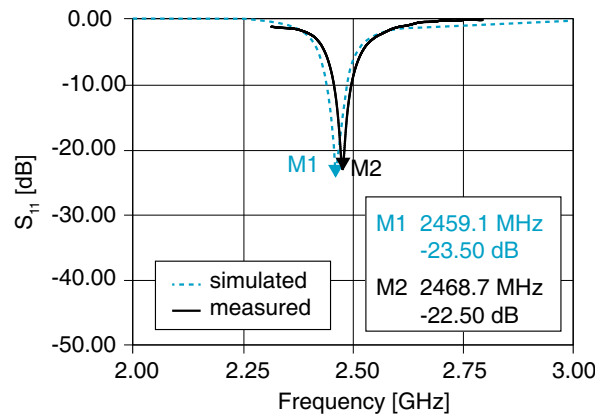

Figure 4. Simulated and measured S_{11} of the antenna.

3.2. Rectifier and Impedance Matching

The rectifier circuit and impedance matching circuit that must be designed to rectenna have the best RF-DC conversion efficiency:

$$\eta = \frac{P_{DC}}{P_{RFin}} \quad (1)$$

where P_{DC} is the power delivered to the load, and P_{RFin} is the RF power harvested by the rectenna.

The rectifier circuit basically consists of a single stage voltage multiplier, and the main components of the rectifier circuit are the diodes that are Zero Bias Detector Schottky, which has a low turn-on voltage necessary to work with low power. The chosen diode was model SMS7630-079LF produced by Skyworks.

To make the impedance matching it is necessary to define the impedance of antenna and the rectifier circuit, taking into account that the diode impedance is nonlinear and depends on the frequency and RF power [14]:

$$Z_{diode} = frequency, P_{RFin} \quad (2)$$

As P_{DC} depends on load (R_L),

$$\eta = \frac{P_{DC}}{P_{RFin}} = \eta(frequency, P_{RFin}, R_L) \quad (3)$$

How the rectenna was built into back of antenna using same PCB is that the impedance of rectifier circuit including parasitic capacitances and inductances was determined from the measurements done with the Vector Network Analyzer (VNA). In this measurement, a circuit with the diodes and a load resistor in parallel with the capacitor was used as a lowpass filter. The power level used in VNA measurements was 6 dBm that is approximately the power to obtain the maximum efficiency appointed by simulations.

With the impedance of antenna and of the rectifier circuit, the impedance matching network circuit was designed by using the Smith Chart tool of Keysight ADS that consists of one inductor of 2.8 nH and one capacitor of 2.2 pF. The load resistance of 3.3 k Ω was determined by simulations to maximize P_{DC} , and the output capacitor of 100 pF is used as a first-order lowpass filter. All simulations of the rectifier circuit were done using the Keysight ADS software with diode SPICE model and the parameters found in the diode datasheet, including parasitic elements. The output voltage at the fundamental frequency of 2.45 GHz from the input power was simulated using the Harmonic Balance Method, which is a good choice when one is working with nonlinear circuits in the frequency domain. Fig. 5 shows the circuit scheme including all components used in each rectenna.

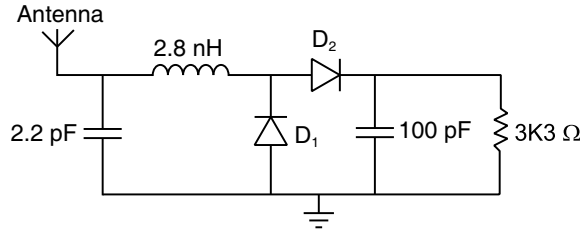

Figure 5. Circuit scheme with input impedance matching, rectifier circuit and DC pass filter.

3.3. Array Configuration

To make the rectenna array reconfigurable, rectennas are independent of each other, and thus it is possible to make the DC output connections as desired. The 2×2 rectenna array layout is shown in Fig. 6. The antennas are positioned with a spacing of 0.10λ between patches, resulting in a mutual coupling less than -15 dB [15].

In the series-association, the connections of ground planes of each rectenna are independent, and the connections between the rectennas were made with copper wires. Fig. 7 illustrates the series-association in the rectenna array.

In the parallel-association, the ground planes of rectennas were connected in the same point, and the rectifiers outputs were also connected in the same point. Fig. 8 illustrates the parallel-association in rectenna array.

In the series-parallel-association, two pairs of rectennas were connected in series, and these pairs were connected in parallel. Fig. 9 illustrates the series-parallel-association in the rectenna array.

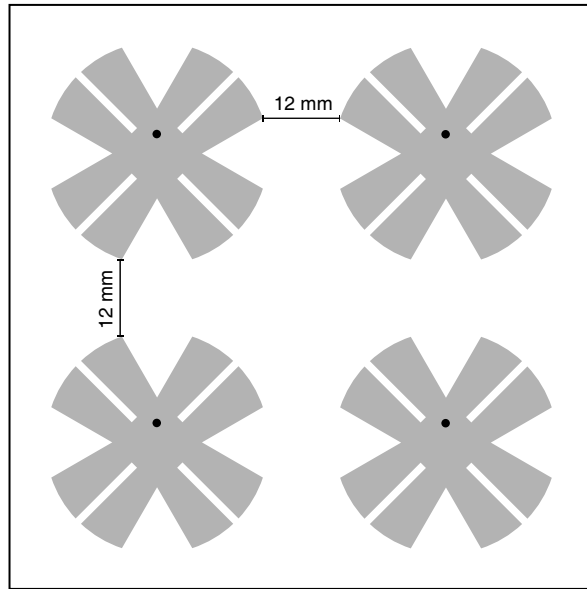

Figure 6. Array layout of the rectennas.

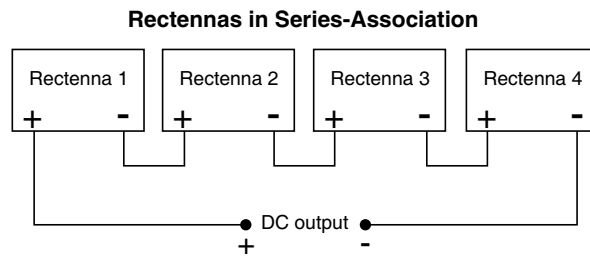

Figure 7. Series-association of rectennas.

Rectennas in Parallel-Association

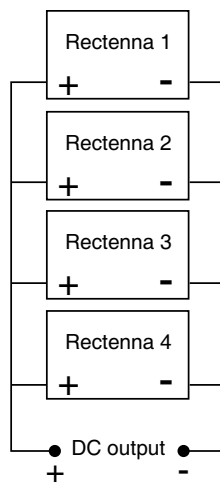

Figure 8. Parallel-association of rectennas.

Rectennas in Series-Parallel-Association

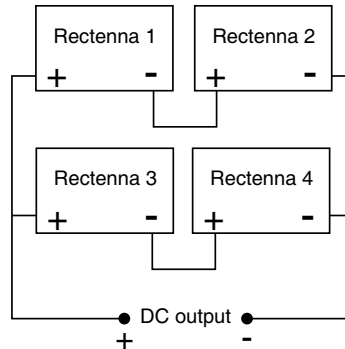

Figure 9. Series-parallel-association of rectennas.

4. RESULTS

To verify the design and make the measurements, a rectenna array prototype was fabricated as shown in Fig. 10. The patch of the antennas was made on a face of a PCB, and on other PCB faces, the grounds planes and rectifiers circuits are made independent to each rectenna.

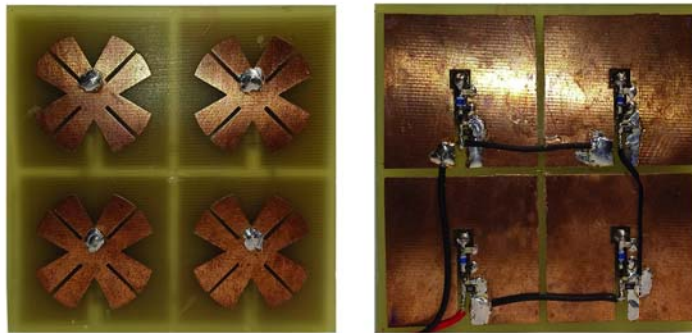

Figure 10. Prototype of rectennas array.

To make the measurements, on the transmitter side, an RF source generated by Rohde&Schwarz SMT03 RF Signal Generator at 2.45 GHz and amplified by an additional power amplifier connected to a transmitter antenna was used. On the receiver side, first the proposed antenna was placed in a fixed position of 50 cm from transmitter antenna, and its received power was measured through a power meter. Then, the antenna was replaced by the rectenna array in the same position, and the rectenna array output voltage was measured using a multimeter as shown in Fig. 11.

To series-association Fig. 12 shows the measured and simulated output DC voltages vs. RF input power, and Fig. 13 shows measured and simulated efficiencies vs. RF input power. The measurements showed a maximum voltage of 7.3 V for an RF input power of 8 dBm, and a maximum efficiency of 64.5% was obtained for an RF input power of 6 dBm.

In the parallel-association Fig. 14 shows the measured and simulated output DC voltages vs. RF input power, and Fig. 15 shows measured and simulated efficiencies vs. RF input power. The measurements showed a maximum voltage of 1.69 V for an RF input power of 8 dBm, and a maximum efficiency of 65.3% was obtained for a RF input power of 5 dBm.

In series-parallel-association Fig. 16 shows measured and simulated output DC voltages vs. RF input power, and Fig. 17 shows measured and simulated efficiencies vs. RF input power. The measurements showed a maximum voltage of 3.21 V for an RF input power 8 dBm, and a maximum efficiency of 64.5% was obtained for an RF input power of 5 dBm.

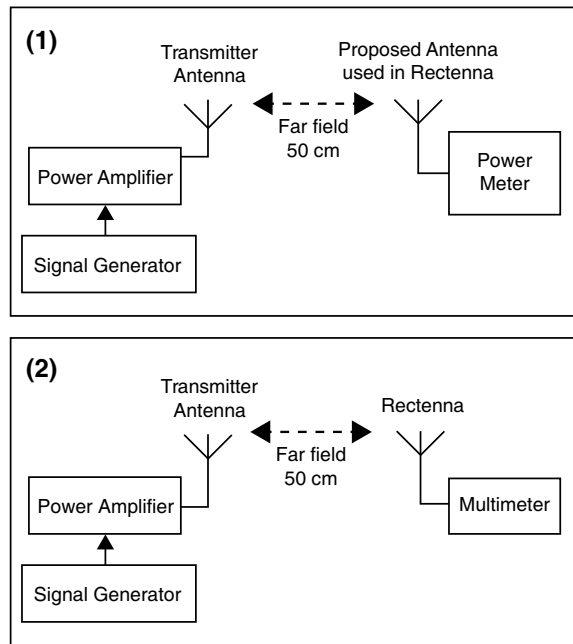

Figure 11. Measurement setup.

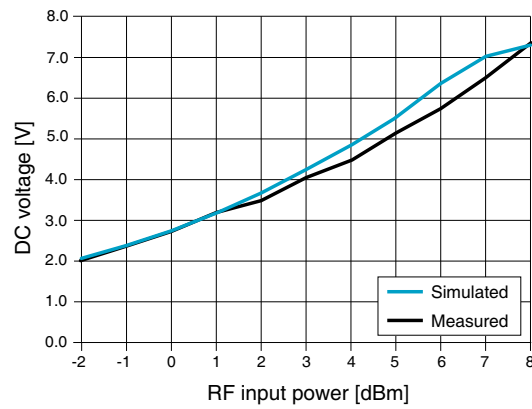

Figure 12. Measured and simulated output DC voltages vs. RF input power (series-association).

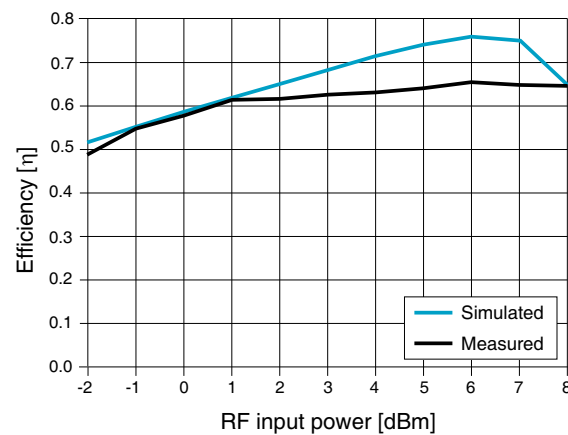

Figure 13. Measured and simulated efficiencies vs. RF input power (series-association).

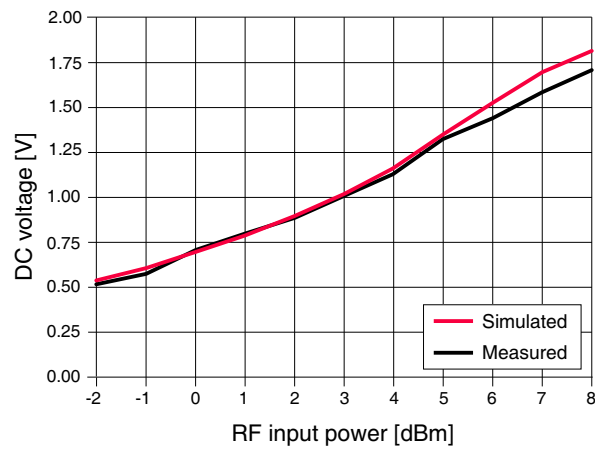

Figure 14. Measured and simulated output DC voltages vs. RF input power (parallel-association).

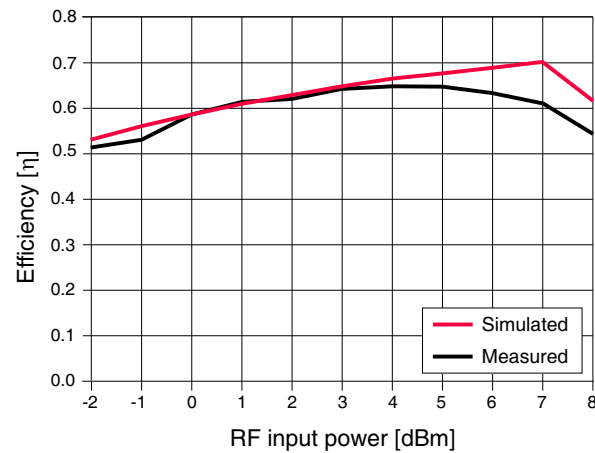

Figure 15. Measured and simulated efficiencies vs. RF input power (parallel-association).

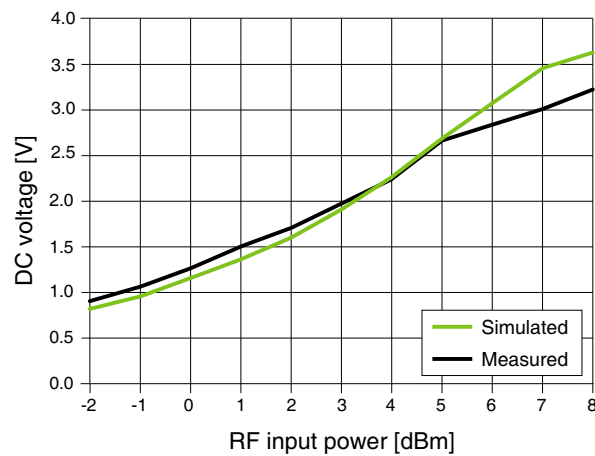

Figure 16. Measured and simulated output DC voltages vs. RF input power (series-parallel-association).

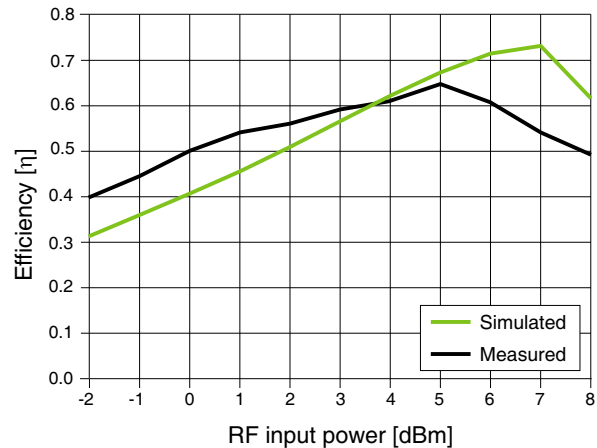

Figure 17. Measured and simulated efficiency vs. RF input power (series-parallel-association).

Fig. 18 shows the rectenna array used as a power supply to a common LCD clock.



Figure 18. Rectenna used as a power supply to an LCD clock.

5. CONCLUSIONS

In this paper, a 2.45 GHz efficient, compact-integrated and reconfigurable rectenna array 2×2 has been developed and tested for three configurations of association: series-association, parallel-association and series-parallel-association.

The peak of voltage observed was 6.51 V for series-association, 1.58 V for parallel-association and 3.00 V for series-parallel-association. In the series-association a maximum efficiency of 64.5% was observed; in the parallel-association a maximum efficiency of 65.3% was observed; in series-parallel-association the maximum efficiency of 64.5% was observed.

With an RF input power of 1 dBm it was possible to obtain 3.2 V approximately using series-association, which is a sufficient DC source of power to operate many types of electronic devices.

A good qualitative agreement is obtained between experimental results and numerical simulations in the frequency operating range of the rectenna array (2.45 GHz), and small differences are due to the effects caused by mutual coupling between rectennas elements and/or by adapters and connectors which were not considered in the simulations.

REFERENCES

1. Brown, W. C., "The history of power transmission by radio waves," *IEEE Consumer Electronics Magazine*, Vol. 32, 9, 1230–1242, 1984.
2. Khemar, A., A. Kacha, H. Takhedmit, and G. Abib, "Design and experiments of a dual-band rectenna for ambient RF energy harvesting in urban environments," *IET Microwaves, Antennas & Propagation*, Vol. 12, No. 1, 49–55, 2018.
3. Lu, P., X.-S. Yang, and B.-Z. Wang, "A two-channel frequency reconfigurable rectenna for microwave power transmission and data communication," *IEEE Transactions on Antennas and Propagation*, Vol. 65, No. 12, 2017.
4. Lee, D.-J., S.-J. Lee, I.-J. Hwang, W.-S. Lee, and J.-W. Yu, "Hybrid power combining rectenna array for wide incident angle coverage in RF energy transfer," *IEEE Transactions on Microwave Theory and Techniques*, Vol. 65, No. 9, 2017.
5. Carvalho, N. B., A. Georgiadis, A. Costanzo, et al., "Critical review on smart clothing product development," *IEEE Transactions on Microwave Theory and Techniques*, Vol. 62, No. 4, 2014.
6. Hamani, A., B. Allard, T.-P. Vuong, et al., "Design of rectenna series-association circuits for radio frequency energy harvesting in CMOS FD-SOI 28 nm," *IET Circuits, Devices & Systems*, Vol. 12, No. 1, 40–49, 2018.
7. Chuma, E. L., L. de la T. Rodriguez, Y. Iano, L. L. Bravo Roger, and M. A. Sanchez-Soriano, "Compact rectenna based on a fractal geometry with a high conversion energy efficiency per area," *IET Microwaves, Antennas & Propagation*, Vol. 12, No. 2, 173–178, 2018.
8. Ladan, S., N. Ghassemi, A. Ghiotto, and K. Wu, "Highly efficient compact rectenna for wireless energy harvesting application," *IEEE Microwave Magazine*, 117–122, 2013.
9. Valenta, C. R. and G. D. Durgin, "Harvesting wireless power: survey of energy-harvester conversion efficiency in far-field wireless power transfer systems," *IEEE Microwave Magazine*, 108–120, 2014.
10. Olgun, U., C.-C. Chen, and J. L. Volakis, "Investigation of rectenna array configurations for enhanced RF power harvesting," *IEEE Antennas and Wireless Propagation Letters*, Vol. 10, 262–265, 2011.
11. Hagerty, A., F. B. Helmbrecht, W. H. McCalpin, R. Zane, and Z. B. Popovic, "Recycling ambient microwave energy with broad-band rectenna arrays," *IEEE Transactions on Microwave Theory and Techniques*, Vol. 52, No. 3, 2004.
12. Zbitou, J., M. Latrach, and S. Toutain, "Hybrid rectenna and monolithic integrated zero-bias microwave rectifier," *IEEE Transactions on Microwave Theory and Techniques*, Vol. 54, No. 1, 2006.
13. Gianvittorio, J. P. and Y. Rahmat-Samii, "Fractal antennas: A novel antenna miniaturization technique, and applications," *IEEE Antennas and Propagation Magazine*, Vol. 44, 20–36, 2002.
14. Falkenstein, E., M. Roberg, and Z. Popovic, "Low-power wireless power delivery," *IEEE Transactions on Microwave Theory and Techniques*, Vol. 60, No. 7, 2012.
15. Pozar, D. M., "Input impedance and mutual coupling of rectangular microstrip antennas," *IEEE Transactions on Antennas and Propagation*, Vol. 30, No. 6, 1982.