

A New Equal Power Quadrature Branch Line Coupler for Dual-Band Applications

Aijaz M. Zaidi¹, Syed A. Imam¹, Binod K. Kanaujia^{2, *}, and Karumudi Rambabu³

Abstract—We present a new equal power quadrature branch line coupler (BLC) for dual-band applications in this paper. A new topology of the dual-band quarter wavelength transmission lines (TL) with the derivation of design equations is also introduced. The proposed BLC is designed using Advanced Design System (ADS) and fabricated on Rogers 5870 at 0.9 GHz and 2.4 GHz center frequencies. The design approach for the proposed dual-band BLC is endorsed by the simulated and measured results. A comparative analysis of this BLC with the previous BLCs is also carried out.

1. INTRODUCTION

Multiband radio frequency circuits are essential components to design compact and low cost multiband wireless communication systems. Branch line couplers and power dividers are a few of the main components used to design a wireless transceiver. For example, the BLC plays a vital role in designing beamforming network/antenna array/Butler Matrix [1–10]. Many structures and design methods were proposed to make these components dual/multiband such as T-shaped TL [11], PI-shaped TL [12–14], PI-shaped TL structure with resonator [15], two-section TL [16], extended port [17], metamaterial [18, 19], composite right left-handed material [20], PI-shaped TL with impedance buffering technique [21] and coupled lines [22–24]. While the conventional BLCs are based on conventional TLs, coupled lines, and metamaterials. The proposed BLC is based on coupled lines and traditional TLs. The coupled lines based BLCs [22, 24] provide a very good amplitude imbalance and phase imbalance respectively, while traditional TLs based BLC [17] provide very good isolation and return loss. The proposed BLC has benefits of the both.

A new equal power quadrature BLC for dual-band applications with a new design methodology is proposed in this paper. A topology for dual-band quarter wavelength ($\lambda/4$) TL is also proposed. The topology is a combination of the coupled line and TL, connected in parallel form. It exhibits quarter wavelength TL characteristics at two frequency bands. Mathematical analysis for the dual-band operation of this topology has also been included in this paper. The proposed dual-band equal power quadrature BLC is obtained by replacing each quarter wavelength TL (where Z_c and $Z_c/\sqrt{2}$ are the characteristic impedances of TLs) of the single band equal power quadrature BLC (Fig. 1(a)) by the proposed topology of dual-band quarter wavelength TL Fig. 1(b). In Fig. 1(b) Z_{e1} , Z_{e2} are characteristic even mode impedances; Z_{odd1} , Z_{odd2} are characteristic odd mode impedances; θ is the electrical length of the coupled lines while Z_{o1} , Z_{o2} , and 2θ are the characteristic impedances and the electrical length of the TLs connected to the corresponding coupled line. To verify the proposed design methodology, a BLC has been designed using Agilent's Technologies ADS and implemented on 0.787 mm thick Rogers 5870 at 0.9 GHz and 2.4 GHz frequencies.

Received 10 January 2018, Accepted 6 March 2018, Scheduled 23 March 2018

* Corresponding author: Binod Kumar Kanaujia (bkanaujia@yahoo.co.in).

¹ Department of Electronics and Communication Engineering, Jamia Millia Islamia University, New Delhi-110025, India. ² School of Computational and Integrative Sciences, Jawaharlal Nehru University, Delhi-110067, India. ³ Department of Electrical and Computer Engineering, University of Alberta, Canada.

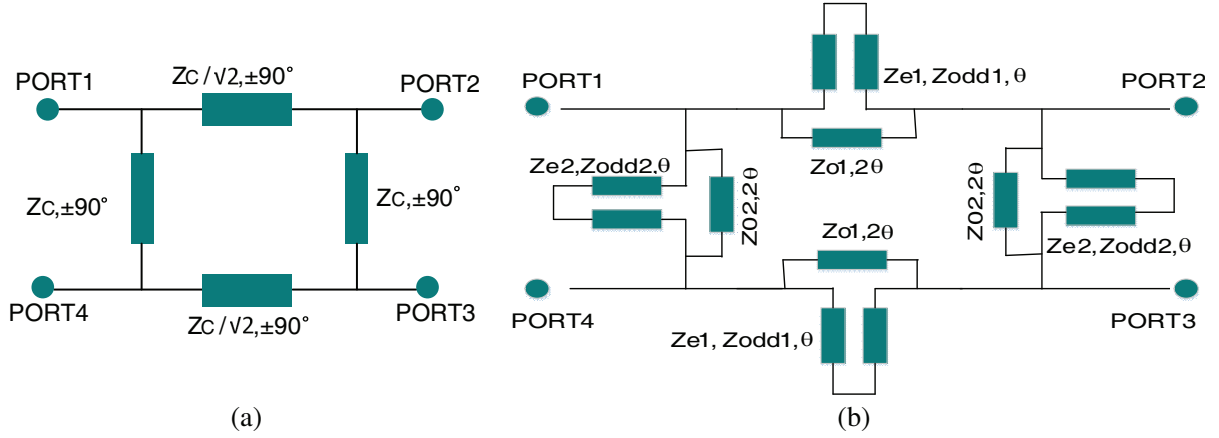

Figure 1. (a) Single band equal power quadrature branch line coupler. (b) Proposed dual band equal power quadrature branch line coupler.

2. TOPOLOGY OF DUAL-BAND $\lambda/4$ TRANSMISSION LINE

The conventional quarter wavelength TL of characteristic impedance Z_C and the proposed topology of dual-band quarter wavelength ($\lambda/4$) TL are shown in Fig. 2. The topology is a combination of the coupled line and conventional TL, connected in parallel form, where Z_e , Z_{odd} and θ are the characteristic even-odd mode impedances and the electrical length of the coupled line respectively, while Z_o is the characteristic impedance, and 2θ is the electrical length of the TL connected to the coupled line. An additional advantage of connecting the TL to the coupled line is that it provides the control on the parameters of the coupled line. Mathematical analysis is explained in the following subsections 2.1–2.3.

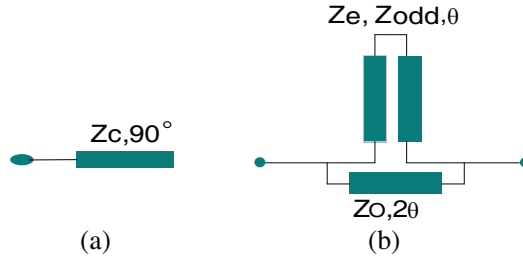

Figure 2. (a) Conventional $\lambda/4$ wavelength transmission line (b) Proposed topology of dual band $\lambda/4$ wavelength transmission line.

2.1. Even Mode Analysis

The equivalent even mode half circuit of the conventional quarter wavelength TL is an open stub of electrical length 45° , and even mode half circuit of the proposed structure is a combination of two open stubs of impedance Z_e and Z_o with electrical length θ connected in parallel form, shown in Fig. 3. Equation (1) is obtained by taking both the even mode half circuits equivalent.

$$Y_e = Y_c \cot \theta - Y_o \quad (1)$$

where $Y_o = 1/Z_o$, $Y_e = 1/Z_e$ and $Y_c = 1/Z_c$.

2.2. Odd Mode Analysis

As shown in Fig. 4, the equivalent odd mode half circuit of the conventional quarter wavelength TL is a short stub of electrical length 45° while the proposed structure is a parallel combination of two short

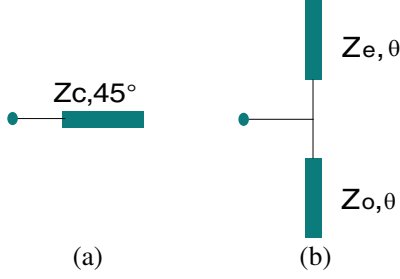

Figure 3. Even-mode half circuit. (a) Conventional $\lambda/4$ wavelength transmission line. (b) Proposed topology of dual band $\lambda/4$ wavelength transmission line.

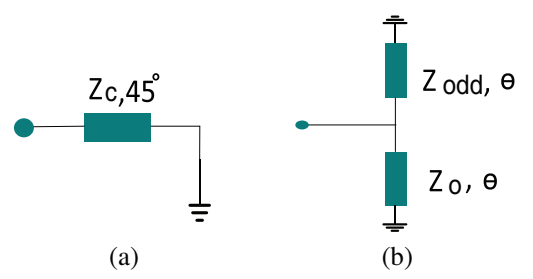

Figure 4. Odd-mode half circuit. (a) Conventional $\lambda/4$ wavelength transmission line. (b) Proposed topology of dual band $\lambda/4$ wavelength transmission line.

stubs of impedance Z_{odd} and Z_o with electrical length θ . Similarly, Eq. (2) is obtained for the odd mode half circuits.

$$Y_{odd} = Y_c \tan \theta - Y_0 \quad (2)$$

where $Y_o = 1/Z_o$, $Y_{odd} = 1/Z_{odd}$ and $Y_c = 1/Z_c$.

2.3. Dual Band Operation

The BLC's (shown in Fig. 1(a)) S -parameters characteristics remain the same for both $+90^\circ$ TL and -90° TL. Here both the cases are considered for dual-band operation. The proposed dual-band quarter wavelength TL is equivalent to the $+90^\circ$ and -90° conventional TLs at f_1 and f_2 , respectively. Eqs. (1) and (2) can be rewritten as

$$Y_e = +Y_c \cot \theta_1 - Y_0 \quad (3)$$

$$Y_e = -Y_c \cot \theta_2 - Y_0$$

$$Y_{odd} = +Y_c \tan \theta_1 - Y_0 \quad (4)$$

$$Y_{odd} = -Y_c \tan \theta_2 - Y_0$$

where θ_1 and θ_2 are the electrical lengths of the coupled lines at the operating frequencies f_1 and f_2 , respectively. Eqs. (3) and (4) will be valid at two frequencies f_1 and f_2 when

$$\theta_1 + \theta_2 = m\pi \quad (5)$$

where $m = 1, 2, 3 \dots$

The values of θ_1 and θ_2 are obtained from Eq. (5). Here, $m = 1$ is taken for the compact size.

$$\theta_1 = \frac{\pi}{1 + K} \quad (6)$$

$$\theta_2 = \frac{K\pi}{1 + K} \quad (7)$$

where K is the ratio of frequencies f_2 and f_1 .

3. DESIGN AND IMPLEMENTATION

For simplicity and fabrication easiness, $Z_c = 50 \Omega$ and $Z_{o1} = 70.7 \Omega$, $Z_{o2} = 100 \Omega$ have been selected for the BLCs shown in Fig. 1(a) and Fig. 1(b), respectively. The values of all the components of the proposed BLC (Fig. 1(b)) have been calculated using Eqs. (1), (2), and (6). The calculated values of all the components with their optimized dimensions are given in Table 1. The proposed BLC has been fabricated on 0.787 mm thick Rogers 5870 with dielectric constant $\epsilon_r = 2.33$ and $\text{Tan}\delta = 0.0012$, shown in Fig. 5. To reduce the size of the BLC, all the four TLs which are connected parallel to the coupled lines make an outer round to the corresponding coupled line. The size of the implemented circuit is 6.4 cm \times 8.3 cm.

Table 1. Dimensions of the components.

Components (TLs)	Impedance/electrical length (ohm)/degree	Width (mm)	Length (mm)	Space (mm)
$Z_{o1}/2\theta$	70.75/98.18	0.92	6.41	-NA-
$Z_{o2}/2\theta$	100/98.18	0.38	5.22	-NA-
$Z_{e1}/Z_{odd1}/\theta$	96.32/53.99/49.09	0.70	27.98	0.32
$Z_{e2}/Z_{odd2}/\theta$	136.43/76.45/49.09	0.54	22.40	1.52

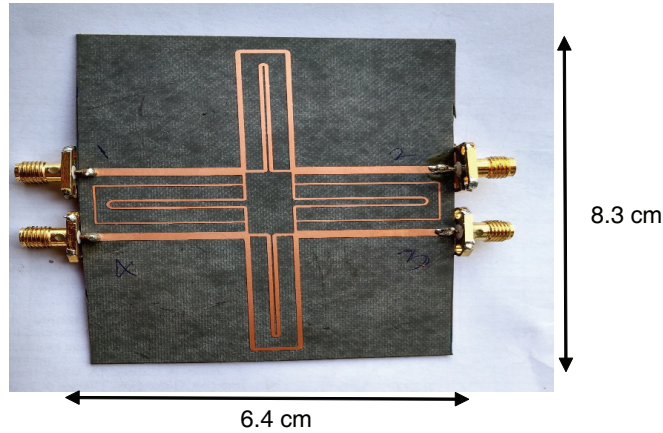
**Figure 5.** Photograph of the fabricated circuit.

4. SIMULATION AND MEASUREMENT RESULTS

The simulated and measured results of the proposed BLC are shown in Figs. 6–11. A good agreement between simulated and measured results is found. The results are summarized in Table-2. Port 1 and port 2, port 3 are considered as the input and output ports, respectively. The simulated and measured results verify that the equal power division ($|S_{21}| = |S_{31}|$) and quadrature phase difference ($\angle S_{21} - \angle S_{31} = \pm 90^\circ/270^\circ$) at port 2 and port 3 have been achieved for both the frequency bands with 0.22 dB maximum amplitude imbalance ($\Delta A = |S_{21}| - |S_{31}|$) and 0.6° maximum phase deviation ($\angle S_{21} - \angle S_{31} = \pm 90^\circ/270^\circ \pm \Delta\varphi$, where $\Delta\varphi$ is the phase deviation) while maintaining the ≤ -26.63 dB

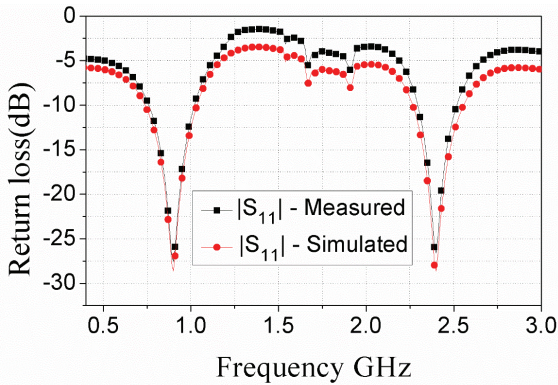
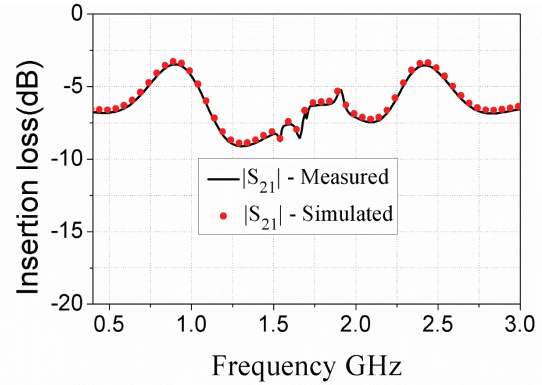
**Figure 6.** Return loss ($|S_{11}|$).**Figure 7.** Insertion loss ($|S_{21}|$).

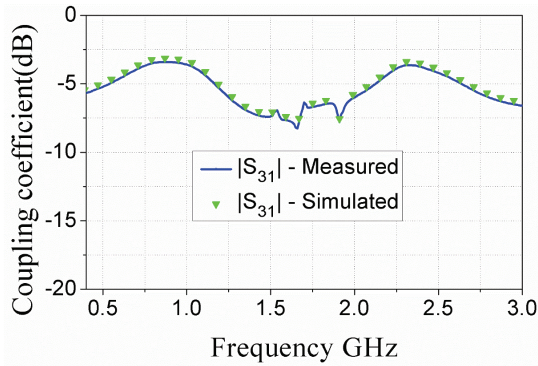

Figure 8. Coupling coefficient ($|S_{31}|$).

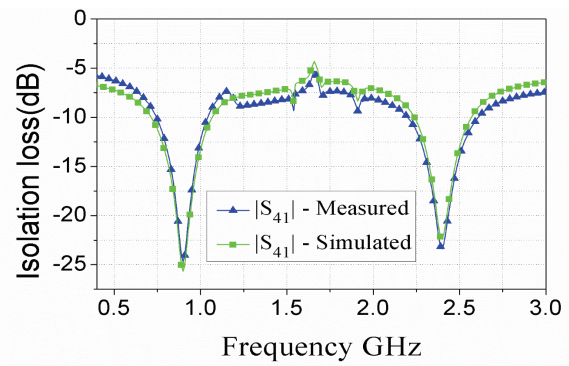

Figure 9. Isolation loss ($|S_{41}|$).

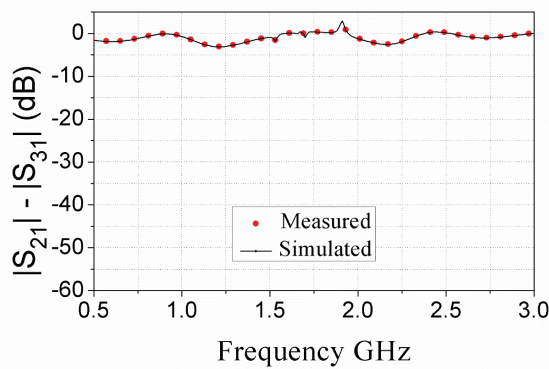

Figure 10. Amplitude imbalance between port 2 and port 3.

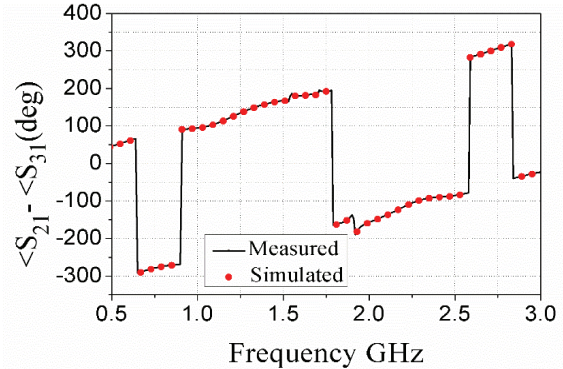

Figure 11. Phase difference between port 2 and port 3.

Table 2. Analysis of simulation and measurement results.

	Simu*	Meas**	Simu*	Meas**
Frequency (GHz)	0.9	0.9	2.4	2.4
Return loss ($ S_{11} $) dB	-28.51	-27.74	-28.49	-26.63
Isolation loss ($ S_{41} $) dB	-25.68	-24.50	-22.28	-23.30
Insertion loss ($ S_{21} $) dB	-3.25	-3.47	-3.35	-3.56
Coupling coefficient ($ S_{31} $) dB	-3.14	-3.41	-3.53	-3.78
$\Delta A(S_{21} - S_{31})$ dB	0.11	0.06	0.18	0.22
$(\angle S_{21} - \angle S_{31})$ degree	-269.8	-269.5	-90.5	-89.4
BW% for $\Delta A = \pm 0.5$ dB	17.62	18.89	10.86	11.67
BW% for $\Delta\varphi = \pm 5^\circ$	26.13	25.56	7.03	5.42
BW% for $1/ S_{11} > 15$ dB	16.52	15.63	6.08	5.21
BW% for $1/ S_{41} > 15$ dB	17.34	16.21	6.53	7.42

Simu* \rightarrow Simulated, Meas** \rightarrow Measured

return loss ($|S_{11}|$) and ≤ -23.30 dB isolation loss ($|S_{41}|$) at the center frequencies of both the frequency bands. The amplitude imbalance is within ± 0.5 dB and is maintained from 0.82 GHz to 0.98 GHz for 0.9 GHz frequency band and 2.33 GHz to 2.60 GHz for 2.4 GHz frequency band, respectively, shown in Fig. 10. The phase deviation within $\pm 5^\circ$ is preserved from 0.79 GHz to 1.01 GHz for 0.9 GHz

Table 3. Comparative analysis of dual band branch line couplers.

Reference	[13]	[17]	[20]	[23]	[24]	This work
Tactic year	Dual PI 2016	Port extn [#] 2010	CRLH 2016	CL 2011	CL 2013	CL + TL 2018
Power division	3 dB	3 dB	3 dB	3 dB	≠ 3 dB	3 dB
Band ratio	0.87/1.79	1/2	0.93/1.78	2/4	2.45/6.17	0.9/2.4
ΔA (dB)	0.37/0.81	0.2/0.6	0.09/0.34	< 0.10/1.20	0.40/0.20	0.06/0.22
$\Delta\varphi$ (degree)	0.7/1.4	0/1	5.3/3.6	3.5/5.7	0.9/0.7	0.5/0.6
BW% for $ S_{11} < -15$ dB	8.8/10.6	15/09 (est [†])	10/10 (est [†])	20/18	12.3/4	15.63/5.21
BW% for $ S_{41} < -15$ dB	9.5/10.6	16/10 (est [†])	9/9 (est [†])	20/20	18/13.5	16.21/7.42

estn[#] → extension, estm[†] → estimated

frequency band and 2.37 GHz to 2.49 GHz for 2.4 GHz frequency band, respectively, shown in Fig. 11. A comparative analysis of this work with existing dual-band BLCs is presented Table 3. This BLC has better amplitude imbalance and phase imbalance than most of the previously designed BLCs at high band ratio with an expense of bandwidth (BW) percentage for return loss and isolation loss for upper band. All these results verify that the proposed design methodology is accurate for designing a dual-band BLC.

5. CONCLUSION

A new equal power, quadrature BLC for dual-band applications with a new design approach has been presented, designed, implemented and verified. A new topology of the dual-band quarter wavelength TL, with complete design equations, has also been introduced here. The performance of the proposed BLC has been demonstrated including return loss, isolation loss, insertion loss, magnitude and quadrature phase condition. The comparative analysis has proved that the presented BLC design has a better magnitude and phase imbalance than the previous BLCs.

ACKNOWLEDGMENT

This work has been supported by the Ministry of Electronics and Information Technology, Government of India under Visvesvaraya PhD scheme. Details can be found on <http://phd.medialabasia.in>, in thrust area.

REFERENCES

1. Titz, D., et al., "New wideband miniature branch line coupler on IPD technology for beamforming applications," *IEEE Transactions on Components, Packaging and Manufacturing Technology*, Vol. 4, No. 5, 911–921, 2014.
2. Kwang, T. K. Gary, and P. Gardner, "4 × 4 Butler matrix beam forming network using novel reduced size branch line coupler," *Microwave Conference, 2001. 31st European*, IEEE, 2001.
3. Comitangelo, R., D. Minervini, and B. Piovano, "Beam forming networks of optimum size and compactness for multibeam antennas at 900 MHz," *Antennas and Propagation Society International Symposium, 1997, IEEE, 1997 Digest*, Vol. 4. IEEE, 1997.
4. Koubeissi, M., et al., "Switched-beam antenna based on novel design of butler matrices with broadside beam," *Electronics Letters*, Vol. 41, No. 20, 1097–1098, Sep. 29, 2005.
5. Lee, J. K. and K. Chang, "Dual-band switched beam array fed by dual-band Butler matrix," *Electronics Letters*, Vol. 47, No. 21, 1164–1165, 2011.
6. Wincza, K., S. Gruszczynski, and K. Sachse, "Integrated four-beam dual-band antenna array fed by broadband Butler matrix," *Electronics Letters*, Vol. 43, No. 1, 7–8, 2007.

7. Wincza, K., et al., "Scalable multibeam antenna arrays fed by dual-band modified Butler matrices," *IEEE Transactions on Antennas and Propagation*, Vol. 64, No. 4, 1287–1297, 2016.
8. Ren, H., et al., "A dual-band phased array antenna system based on Butler Matrix network," *Antennas and Propagation Society International Symposium (APSURSI)*, IEEE, 2013.
9. Zhou, C., et al., "A novel compact dual-band Butler matrix design," *2014 3rd Asia-Pacific Conference on Antennas and Propagation (APCAP)*, IEEE, 2014.
10. Jizat, N. M., S. K. A. Rahim, and T. A. Rahman, "Dual band beamforming network integrated with array antenna," *2010 Fourth Asia International Conference on Mathematical/Analytical Modelling and Computer Simulation (AMS)*, IEEE, 2010.
11. Zhang, H. and K. J. Chen, "A stub tapped branch-line coupler for dual band operations," *IEEE Microw. Wireless Compon. Lett.*, Vol. 17, No. 2, 106–108, Feb. 2007.
12. Cheng, K.-K. M. and F.-L. Wong, "A novel approach to the design and implementation of dual-band compact planar 90° branch-line coupler," *IEEE Transactions on Microwave Theory and Techniques*, Vol. 52, No. 11, 2458–2463, Nov. 2004.
13. Gai, C., Y.-C. Jiao, and Y.-L. Zhao, "Compact dual-band branch-line coupler with dual transmission lines," *IEEE Microwave and Wireless Components Letters*, Vol. 26, No. 5, 325–327, 2016.
14. Cheng, K.-K. M. and S. Yeung, "A novel dual-band 3-dB branch-line coupler design with controllable bandwidths," *IEEE Transactions on Microwave Theory and Techniques*, Vol. 60, No. 10, 3055–3061, Oct. 2012.
15. Wang, Z. and C.-W. Park, "Multiband pi-shaped structure with resonators for tri-band Wilkinson power divider and tri-band rat-race coupler," *Microwave Symposium Digest (MTT), 2012 IEEE MTT-S International*, IEEE, 2012.
16. Srisathit, S., M. Chongcheawchamnan, and A. Worapishet, "Design and realization of dual-band 3dB power divider based on two-section transmission-line topology," *IEE Electronics Letters*, Vol. 39, No. 9, 723–724, May 1, 2003.
17. Kim, H., B. Lee, and M.-J. Park, "Dual-band branch-line coupler with port extensions," *IEEE Transactions on Microwave Theory and Techniques*, Vol. 58, No. 3, 651–655, 2010.
18. Lin, I.-H., C. Caloz, and T. Itoh, "A branch-line coupler with two arbitrary operating frequencies using left-handed transmission lines," *2003 IEEE MTT-S International Microwave Symposium Digest*, Vol. 1, 2003.
19. Lin, I.-H., et al., "Arbitrary dual-band components using composite right/left-handed transmission lines," *IEEE Transactions on Microwave Theory and Techniques*, Vol. 52, No. 4, 1142–1149, 2004.
20. Wang, Q., J. Lim, and Y. Jeong, "Design of a compact dual-band branch line coupler using composite right/left-handed transmission lines," *Electronics Letters*, Vol. 52, No. 8, 630–631, 2016.
21. Piazzon, L., P. Saad, P. Colantonio, F. Giannini, K. Andersson, and C. Fager, "Branch-line coupler design operating in four arbitrary frequencies," *IEEE Microw. Wireless Compon. Lett.*, Vol. 22, No. 2, 67–69, Feb. 2012.
22. Yu, J.-H., J.-C. Cheng, and Y.-H. Pang, "Design of a dual-band miniaturized 90 branch-line coupler with coupled lines," in *Proc. Asia Pacific Microw. Conf.*, 5–8, 2011.
23. Yeung, L. K., "A compact dual-band 90 coupler with coupled-line sections," *IEEE Transactions on Microwave Theory and Techniques*, Vol. 59, No. 9, 2227–2232, Sep. 2011.
24. Yu, C.-H. and Y.-H. Pang, "Dual-band unequal-power quadrature branch-line coupler with coupled lines," *IEEE Microwave and Wireless Components Letters*, Vol. 23, No. 1, 10–12, 2013.