

# Compact Microstrip Balanced-to-Balanced Diplexer Using Stub-Loaded Triple-Mode Resonators

Chao Zhang\*, Li Zhu, and Yuehua Li

**Abstract**—In this paper, a new microstrip balanced-to-balanced diplexer is presented and investigated. The proposed diplexer primarily consists of two balanced bandpass filter paths, and each balanced filter path can be designed independently based on two identical stub-loaded triple-mode resonators. It should be mentioned that no extra matching networks are required at the common balanced input port in the design. For demonstration, a prototype balanced-to-balanced diplexer operating at 2.30 and 2.83 GHz is designed, fabricated and measured with 3-dB fractional bandwidths of 13.0% and 13.4%. Both simulated and measured results are provided in satisfactory agreement.

## 1. INTRODUCTION

Diplexer, which is a significant RF component for communication system, is a three-port network that splits the incoming signals from a common port into two channels with different operating frequencies. The classical diplexers such as microstrip diplexer [1, 2], having the advantages of its low cost and compact layout, have been widely studied in the past decades. Most microstrip diplexers in published literatures focus on the single-ended configuration, and the balanced circuits are widely used in modern communication systems due to the superiority with good common-mode (CM) rejection and higher immunity to noise [3, 4], than the conventional single-ended counterparts. Hence, for balanced circuits connecting, balanced diplexer has gained special attention in the last few years. For instance, hybrid microstrip and slot-line was introduced in dual-band diplexer in [5] to effectively suppress the CM signals. However, the structure was relatively complex. Besides, a quad-band diplexer was designed in [6], and stepped-impedance resonator inserted T-junctions were employed as matching network. Nevertheless, the circuits with T-junction occupy large circuit areas obviously. To reduce the size of communication system, some balanced diplexers without T-junctions have been studied [7–10]. Zhou et al. [8] proposed a balanced diplexer with uniform impedance resonators and short-ended microstrip parallel-coupling feedlines. Although the filter in the diplexer is able to work without extra junction matching network, but the performance in upper passband can not achieve as that in lower passband. In addition, with dual-open/short-stub loaded resonator, Wei Jiang et al. designed a quad-channel diplexer [9], but it was only suitable for narrow-band application. By applying 16 close loops, a via-free and compact diplexer was proposed in [10]. However, both the return losses and insertion losses were poor. Therefore, it is significant to further improve the performance of the balanced diplexers.

A new balanced-to-balanced diplexer is introduced in this paper. The proposed balanced diplexer includes two balanced bandpass filter paths. Each balanced bandpass filter path can be designed independently based on two identical stub-loaded triple-mode resonators. Note that the proposal is designed without extra matching networks at the common balanced input port. For demonstration, a prototype balanced-to-balanced diplexer operating at 2.30 and 2.83 GHz is designed, fabricated and

---

*Received 25 October 2017, Accepted 24 March 2018, Scheduled 7 April 2018*

\* Corresponding author: Chao Zhang (enndychang@163.com).

The authors are with the School of Electronic and Optical Engineering, Nanjing University of Science and Technology, Nanjing, China.

measured with 3-dB fractional bandwidths of 13.0% and 13.4%. The structure of diplexer is compact and the performance of practical diplexer agrees well with the simulated ones.

## 2. DESIGN OF BALANCED-TO-BALANCED DIPLEXER

The proposed balanced-to-balanced diplexer includes two balanced filter channels, in which channel a pair of stub-loaded triple-mode resonators is adopted. Fig. 1(a) depicts the schematic view of the involved stub-loaded triple-mode resonator. The characteristics of resonator can be expounded with even-/odd-mode theory. With the reference to [11], the input admittance of even-/odd-mode equivalent circuits can be determined to be

$$Y_{ino} = -jY_1 \cdot \cot \theta_1 \quad (1)$$

$$Y_{ine} = Y_1 \cdot \frac{jY_2 \cdot (\tan \theta_2 - \cot \theta_3)/2 + jY_1 \cdot \tan \theta_1}{Y_1 + Y_2 \cdot \tan \theta_1 \cdot (\cot \theta_3 - \tan \theta_2)/2} \quad (2)$$

where  $\theta_i = 2\pi f L_i \sqrt{\varepsilon_e}/c$ ,  $i = 1, 2, 3$ ,  $c$  is the speed of light in free space, and  $\varepsilon_e$  and  $Y_i$  ( $i = 1, 2, 3$ ) are the effective dielectric constant and characteristic admittance of microstrip line.

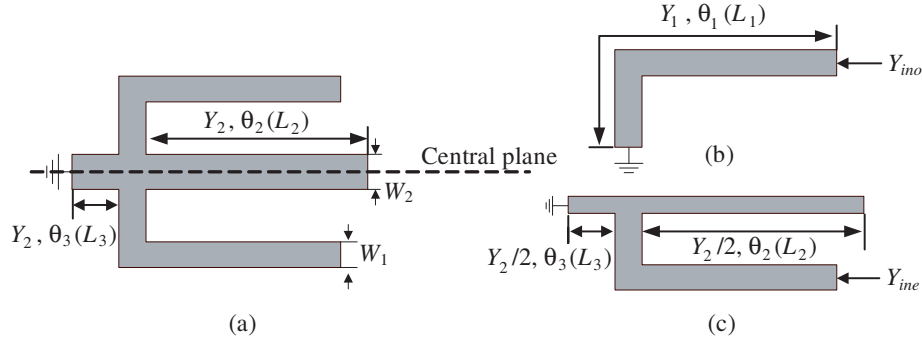

**Figure 1.** The schematic of proposed resonator.

By enforcing  $Y_{ino} = 0$  and  $Y_{ine} = 0$ , the odd- and even-mode resonance conditions can be deduced by

$$\theta_1 = \pi/2 \quad (3)$$

$$2Y_1 \cdot \tan \theta_1 + Y_2 \cdot (\tan \theta_2 - \cot \theta_3) = 0 \quad (4)$$

Then, within the interested frequency range, one odd-mode and two even-modes of involved resonator are achieved. According to the above design equations, the resonant frequencies of the resonator are related to the parameters of  $Y_i$  and  $\theta_i$ . Thus, the fundamental odd- and even-mode frequencies can be well controlled by adjusting its physical parameters, i.e.,  $W_1$ ,  $W_2$ ,  $L_1$ ,  $L_2$  and  $L_3$ .

Based on the above analysis, a new tri-mode balanced-to-balanced diplexer can be designed with resorting to the above mentioned resonators. Fig. 2 depicts the configuration of the proposed balanced diplexer. Basically, the diplexer is composed of two balanced filter channels with two pairs of forenamed stub-loaded resonators. Two balanced filter channels are directly connected through a common open-circuited half-wavelength transmission line without any matching network. As shown in Fig. 2, each balanced filter channel is symmetrical to the central plane of the input/output feed lines.

The equivalent circuits of the proposed diplexer under differential-mode (DM)/CM excitations are illustrated in Fig. 3.

When the differential-mode signals are applied to the input ports, a virtual-short-to-ground is present along the symmetric line. The corresponding equivalent circuit can be obtained as shown in Fig. 3(a). As we can observe, the bandpass-type coupled-line is formed at both input/output ports under DM excitation, thus two triple-mode bandpass filtering responses can be performed between the input and two output ports. Fig. 4 gives the related coupling scheme of the proposed diplexer under DM excitation. Port  $1^+/1^-$  is the balanced input port, then Port  $2^+/2^-$  and Port  $3^+/3^-$  are output

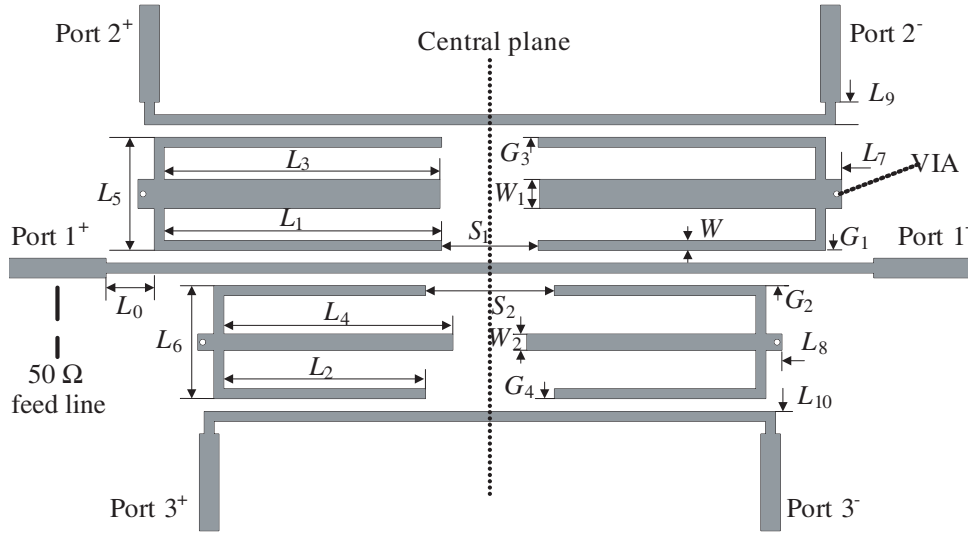

Figure 2. The configuration of proposed balanced diplexer.

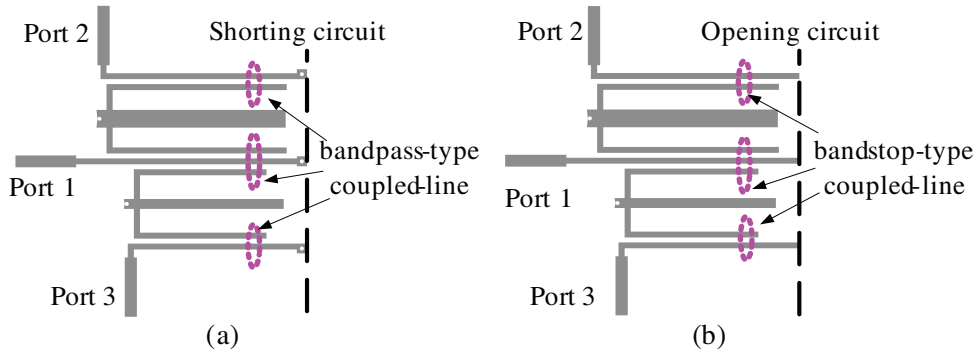

Figure 3. Equivalent circuit of proposed diplexer (a) differential-mode (b) common-mode.

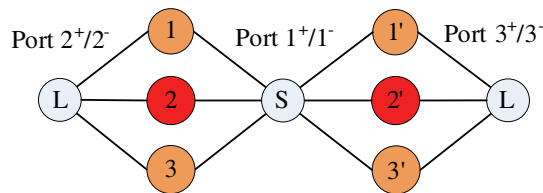
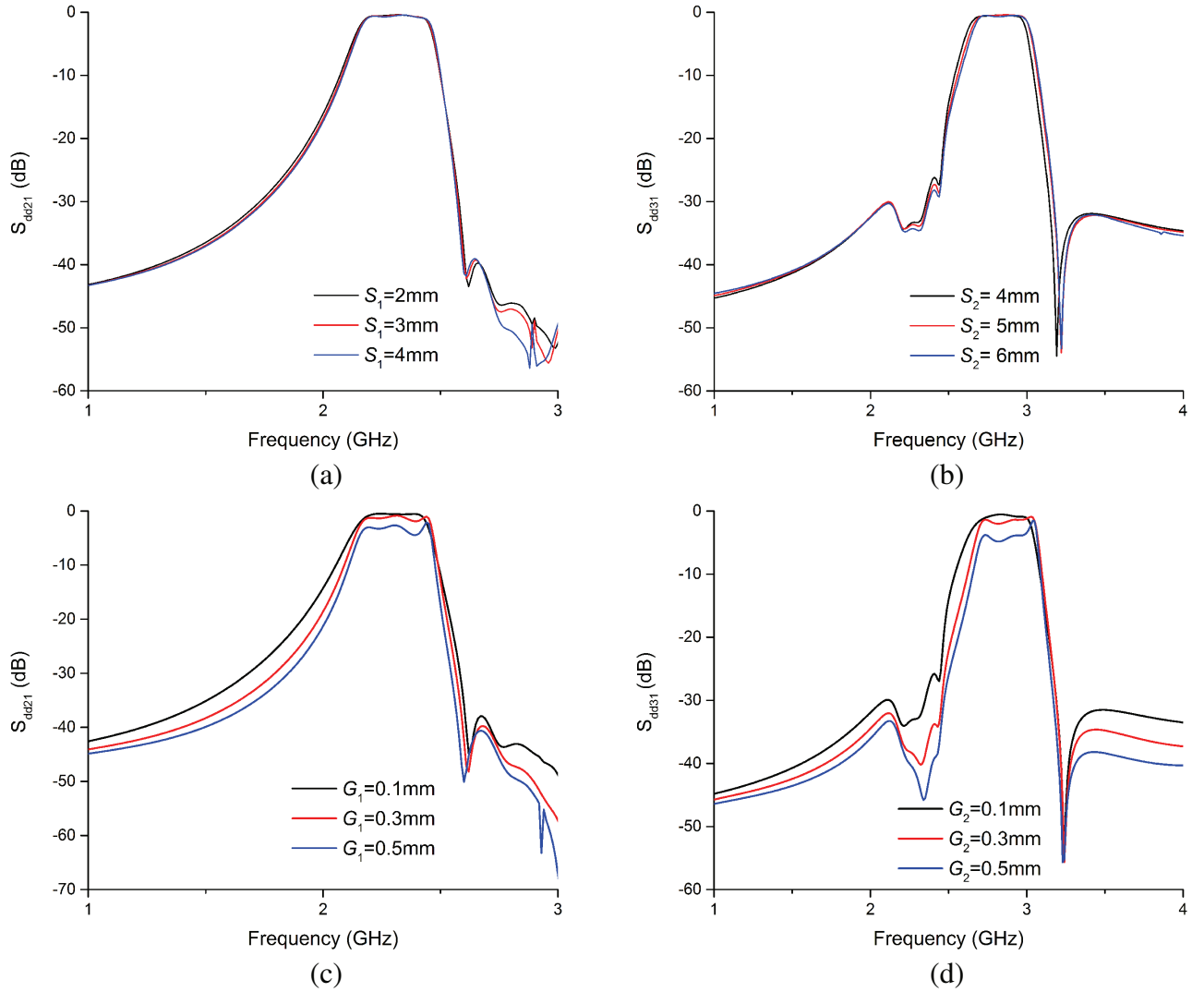

Figure 4. Coupling of proposed balanced diplexer under differential-mode excitation.

ports. Nodes (1, 2, 3 and 1', 2', 3') represent the resonant modes of stub-loaded resonators in two filter channels. Indeed, the coupling topology is only applied to synthesize the desired frequency responses nearby the passband. It should be noted that the bandwidth of these dual working passbands can be adjusted individually by fine tuning the lengths ( $L$ ,  $S_1$  and  $S_2$ ) and the gaps ( $G_1/G_3$ ,  $G_2/G_4$ ). Fig. 5 shows the effect of variable design parameters of  $S_1/S_2$  and  $G_1/G_2$  on  $S_{dd21}/S_{dd31}$  under the assumption that other parameters are kept identical. As indicated in Figs. 5(a) and (b), the centre frequency and bandwidth of our diplexer are shifted slightly with different  $S_1/S_2$ . Figs. 5(c) and (d) show that the performance of  $S_{dd21}/S_{dd31}$  deteriorates with the increase of  $G_1/G_2$ .

Alternatively, an open-circuited-to-ground boundary condition is present along the symmetric line under CM operation. Under this circumstance, the signals at the input port can't be transmitted to two output ports due to the bandstop-type coupled-line as illustrated in Fig. 3(b).



**Figure 5.** The effect of key parameters on the performance of proposed balanced diplexer. (a) Response of  $S_{dd21}$  with different  $S_1$ . (b) Response of  $S_{dd31}$  with different  $S_2$ . (c) Response of  $S_{dd21}$  with different  $G_1$ . (d) Response of  $S_{dd31}$  with different  $G_2$ .

### 3. IMPLEMENTATION AND MEASUREMENT

In order to verify our design concept, a prototype of balanced-to-balanced diplexer working at 2.30 and 2.83 GHz is designed and fabricated on a 0.508 mm thick Rogers RO4003C substrate with permittivity of 3.55, loss tangent of 0.0027. Final dimensions labeled in Fig. 2 are summarized as follows (Units: mm):  $L_0 = 1.2$ ,  $L_1 = 17.4$ ,  $L_2 = 12.8$ ,  $L_3 = 17.6$ ,  $L_4 = 14.65$ ,  $L_5 = 6.6$ ,  $L_6 = 6.7$ ,  $L_7 = 0.7$ ,  $L_8 = 0.7$ ,  $L_9 = 2$ ,  $L_{10} = 2$ ,  $W = 0.4$ ,  $W_1 = 1.8$ ,  $W_2 = 0.8$ ,  $S_1 = 1.2$ ,  $S_2 = 5$ ,  $G_1 = 0.15$ ,  $G_2 = 0.13$ ,  $G_3 = 0.15$ ,  $G_4 = 0.13$ . The photograph of fabricated diplexer is shown in Fig. 6. The dimension of practical diplexer is about  $0.55\lambda_g \times 0.26\lambda_g$ , where  $\lambda_g$  is the guided wavelength at 2.30 GHz.

The simulation is carried out by Ansys HFSS and measured with four-port vector network analyzer Agilent N5244A. The performances of simulation and measurement are in good agreement and they are both illustrated in Fig. 7.

For the DM operation, as shown in Fig. 7(a), the measured DM fractional bandwidths are of 13.0% and 13.4%, respectively, with two central frequencies of 2.30 and 3.83 GHz. The measured minimum

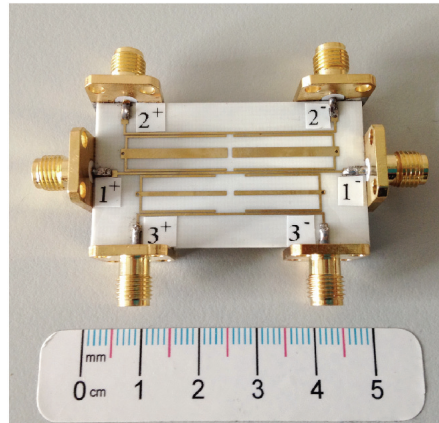

Figure 6. The photograph of the practical balanced-to-balanced diplexer.

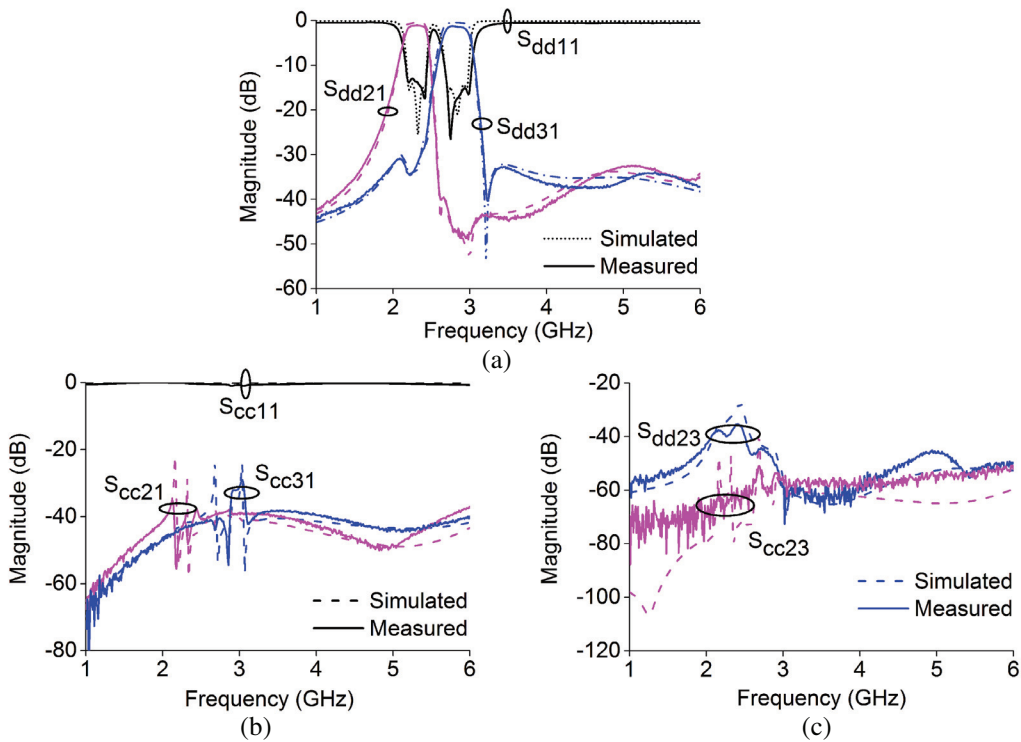

Figure 7. Performance of diplexer (simulated and measured). (a) Differential-mode responses. (b) Common-mode suppression. (c) Isolation.

in-band insertion losses are about 1.06 and 1.24 dB, while both return losses are better than 13 dB. Besides, in our design, transmission zeros at upper side of the passband in Fig. 7(a) are introduced when the middle open-stub microstrip line length of the resonator approximately equals to a quarter-wavelength [12]. The transmission zeros outside the passbands help us a lot to improve the frequency selectivity. As for CM response, the suppressions in both channels are better than 29 dB, which shown in Fig. 7(b). Fig. 7(c) depicts the isolation between two filter channels under DM/CM operation, which is better than 35 dB respectively. The slight distinction between measured and simulated results can be attributed to the fabrication tolerance and the loss from SMA connectors.

#### 4. CONCLUSIONS

In this paper, a new balanced-to-balanced microstrip diplexer is proposed and designed. The proposed balanced diplexer primarily consists of two balanced bandpass filter paths, and each balanced path can be designed independently based on two identical stub-loaded triple-mode resonators. For demonstration, a prototype balanced diplexer is implemented and measured. The results show good performance of the proposed balanced diplexer, with high CM suppression and good isolation. Owing to these properties, it is our belief that the proposed balanced diplexer can obtain widespread application in many balanced circuit systems.

#### REFERENCES

1. Henryk, G., "Microwave diplexer with direct coupled filters," *12th International Conference on Microwaves and Radar*, Vol.2, 620–623, 1998.
2. Srisathit, S., S. Patisang, R. Phromloungsri, S. Bunnjaweht, S. Kosulvit, and M. Chongcheawchaman, "High isolation and compact size microstrip hairpin diplexer," *IEEE Microw. Wireless Compon. Lett.*, Vol. 15, No. 2, 101–103, 2005.
3. Xia, B., L. S. Wu, and J. F. Mao, "A new balanced-to-balanced power divider/combiner," *IEEE Trans. Microw. Theory Tech.*, Vol. 60, No. 9, 2791–2798, 2012.
4. Feng, W. J., W. Q. Che, and Q. Xue, "The proper balance: overview of microstrip wideband balance circuits with wideband common mode suppression," *IEEE Microw. Mag.*, Vol. 16, No. 5, 55–68, 2015.
5. Chan, H.-L., C.-H. Lee, and Chung-I G. Hsu, "Balanced dual-band diplexer design using microstrip and slot-line resonators," *Asia-Pacific Microwave Conference*, Vol. 3, 1–3, 2015.
6. Lee, C.-H., C.-I. G. Hsu S.-X. Wu, and P.-H. Wen, "Balanced quad-band diplexer with wide common-mode suppression and high differential-mode isolation," *IET Microw. Antenna P.*, Vol. 10, No. 6, 599–603, 2016.
7. Lobato-Morales, H. S., J. S. Sun, A. Corona-Chavez, T. Itoh, and J. L. Olvera-Cervantes, "UWB and WiLAN microstrip diplexer for differential-mode operation," *IEEE MTT-S Int. Microwave Symp. Dig.*, 1–3, 2012.
8. Zhou, Y. G., H. W. Deng, and Y. Zhao, "Compact balanced-to-balanced microstrip diplexer with high isolation and Common-Mode suppression," *IEEE Microw. Wireless Compon. Lett.*, Vol. 24, No. 3, 143–145, 2014.
9. Jiang, W., Y. Huang, T. Wang, Y. Peng, and G. Wang, "Microstrip balanced quad-channel diplexer using dual-open/short-stub loaded resonator," *IEEE MTT-S Int. Microwave Symp.*, 1–3, 2016.
10. Arbelaez-Nieto, A., J. Olvera-Cervantes, and A. Corona-Chavez, "A novel via-free microstrip balanced-to-balanced diplexer for narrow-band applications," *Microw. Opt. Techn. Lett.*, Vol. 57, No. 3, 567–570, 2015.
11. Chen, C.-F., T.-M. Shen, T.-Y. Huang, and R.-B. Wu, "Design of compact quadruplexer based on the tri-mode net-type resonators," *IEEE Microw. Wireless Compon. Lett.*, Vol. 21, No. 10, 534–536, 2011.
12. Chen, C.-F., "Design of a compact microstrip quint-band filter based on the tri-mode stub-loaded stepped-impedance resonators," *IEEE Microw. Wireless Compon. Lett.*, Vol. 22, No. 7, 357–359, 2012.