

Experimental Study of Metal-to-Metal Contact Shapes Effects on Passive Intermodulation

Gilles Duteil^{1, *}, Patrick Le Cam², Franck Colombel¹,
Stephane Avrillon¹, Jérôme Plet², and Jean P. Harel²

Abstract—This paper describes an experimental study of passive intermodulation due to metal-to-metal contacts with focus on shape influence. This study investigates PIM value of different contact geometric profiles and different contact areas versus normal forces. A complete description of profiles used is done to achieve a relationship between PIM level and contact shape.

1. INTRODUCTION

Effects of passive intermodulation (PIM) products are growing concerns in mobile network context. These unwanted signals may cause degradation of radio communication quality of service. Considering two carriers, the intermodulation frequency F_{PIM} is described by:

$$F_{PIM} = mF_1 \pm nF_2 \quad (1)$$

where F_1 and F_2 are the two carrier frequencies, and $|m + n|$ provides the intermodulation order. According to [1–3], these phenomena are created by nonlinearities from, for example, dirty surfaces, loose connections or poor soldering. Nowadays, the specified PIM level of base station antennas (i.e., -107 dBm with two carriers power at 43 dBm [4]) makes PIM failures removing long, tedious and expensive for manufacturers of radiofrequency devices.

Some experimental studies on PIM effect in metal-to-metal contact have been published [5–8]. Nevertheless, majority of them are focused on surface roughness profile and the cleanliness of surfaces. Investigation on contact shape impact on PIM is only depicted in [5]. The authors observed the PIM level evolution as a function of the normal forces applied to the contact with different shapes. These contacts are described using three different profiles which are themselves described by three different contacts areas. According to obtained results, the authors conclude that contact shapes have more influence on PIM level than contact area. However, besides studies conditions are not compliant with the 3GPP specification [4], the investigated contact shapes are not representative of currents contact used in base station antennas.

The previous paper [7] shows studies about influence of metal-to-metal contact roughness profiles and cleanliness of surfaces on the passive intermodulation level as function of the normal force applied to this contact. Nevertheless, only one metal-to-metal contact shape was used to perform investigations. This is why this article proposes an investigation on metal-to-metal contact shapes influence on the passive intermodulation level as a function of the normal force applied to this contact, into a base station antenna context. In the first part, complete geometric descriptions and mechanical simulations of different metal-to-metal contacts are depicted. The second part focuses on investigations of the PIM trend as a function of contact shapes.

Received 18 October 2017, Accepted 11 March 2018, Scheduled 28 March 2018

* Corresponding author: Gilles Duteil (gilles.duteil@univ-rennes1.fr).

¹ Institute of Electronics and Telecommunications of Rennes, UMR CNRS 6164, University of Rennes 1, France. ² Radio Frequency Systems, Lannion, France.

2. MECHANICAL STUDIES OF CONTACT SHAPES

The test bench, described in [7], has been used to perform the investigation of contact shapes influence on PIM level as a function of the normal forces applied to the contact. It allows a PIM measurement at 910 MHz for forces increasing from 0 to 7.5 kN. These conditions permit comparisons with the forces that may be provided by screws, which are often used in base station antennas. The test setup, depicted in Figure 1, is based on the typical design of transmission line in base station antenna. To investigate the effect of contact shapes, brass blocks have been modified. Consequently, two surface profiles have been manufactured. The surface profiles are defined using the Radio Frequency Systems knowledge. Furthermore, to permit evaluation of contact area impact on PIM, each profile has been described for two contact areas.

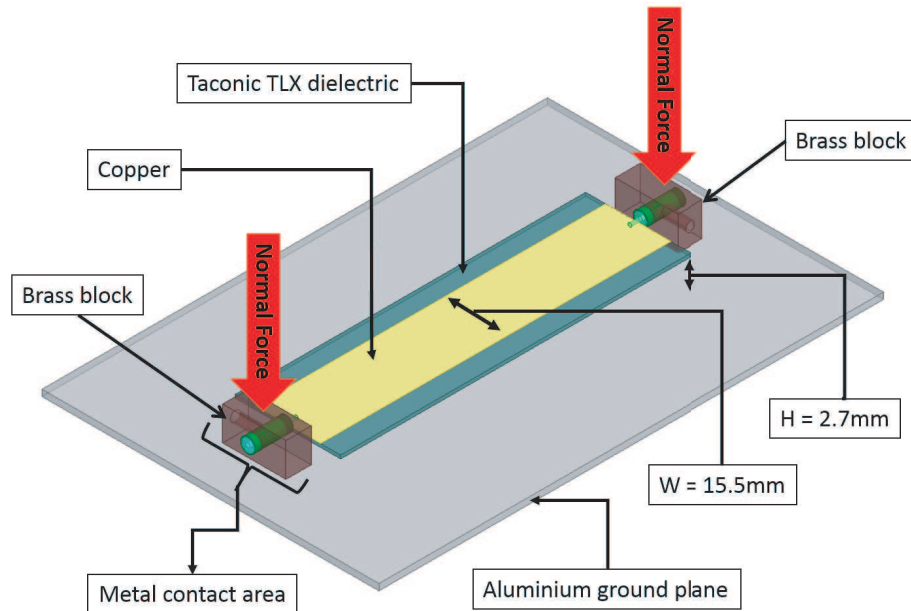

Figure 1. Test setup synoptic.

According to Figure 2, the first shape is defined by hollowing off the central part of brass blocks. Mechanical dimensions of the deleted part, L_c and W_c , are determined such that the contact areas are 45 mm^2 and 60 mm^2 . The second shape is obtained by cutting two grooves on the contact surface. The dimension of grooves, L_g , is defined to have the same contact areas.

According to [7], surface roughness impacts PIM level. To limit this, brass blocks have been manufactured with R_a parameter [9], which describes the arithmetic mean deviation of measured profile, ranging from $0.3 \mu\text{m}$ to $0.4 \mu\text{m}$ along X-axis and from $0.4 \mu\text{m}$ to $0.55 \mu\text{m}$ along Y-axis.

The aluminium ground plane is softer than brass blocks. As shown in Figure 3, when a normal force is applied to the brass block, it penetrates the ground plane. According to Figure 4, this penetration leads to metal-to-metal contact creation on block edges. Moreover, forces applied to metal-to-metal contacts, located between brass block edges and the ground plane, are tangential to the normal force provided by hydraulic cylinders. This relationship leads to that the force applied to new metal-to-metal contacts is almost 0 kN. Nevertheless, the penetration is dependent on normal force, contact area, and surface profile. Table 1 provides results, obtained by mechanical simulations [10], of the penetration area in ground plane for each contact shape used in this article. It appears that brass blocks with grooves have less penetration area than hollowed-out blocks. For 45 mm^2 contact area, the block with grooves obtains an area ratio, between penetration and contact area, of 108.4% whereas the ratio for hollowed-out block is 128.4%. For 60 mm^2 , the first one gets a 111.8% when the second one has a 118.3% ratio.

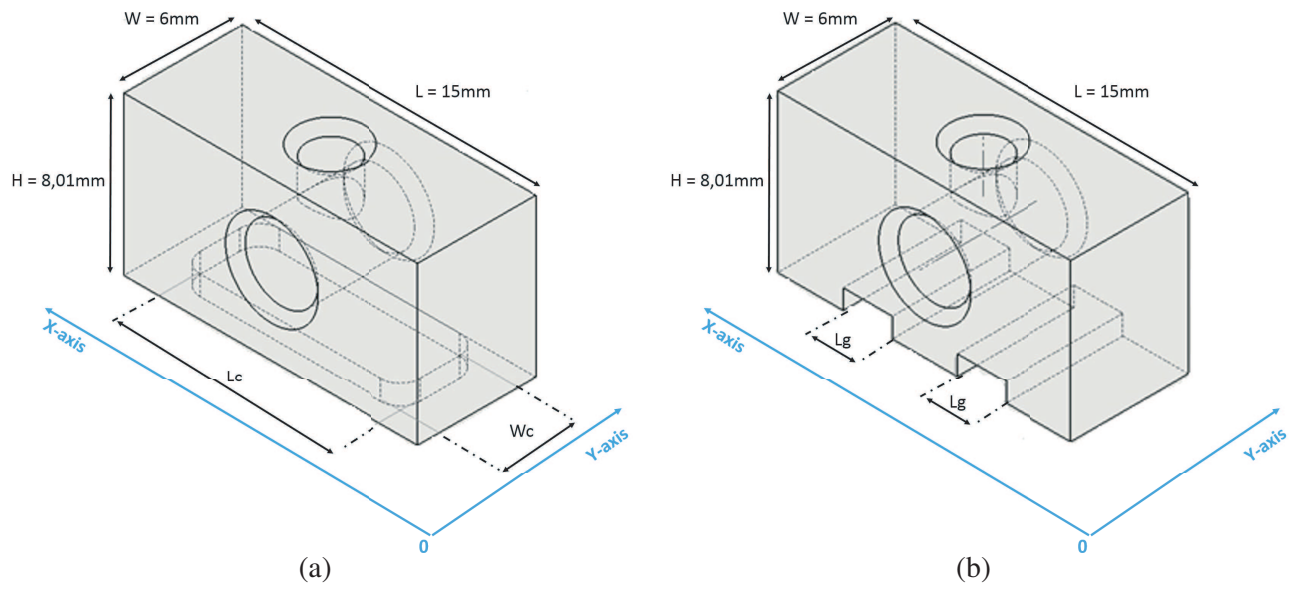

Figure 2. Mechanical design of (a) hollowed-out brass block, (b) grooves brass block.

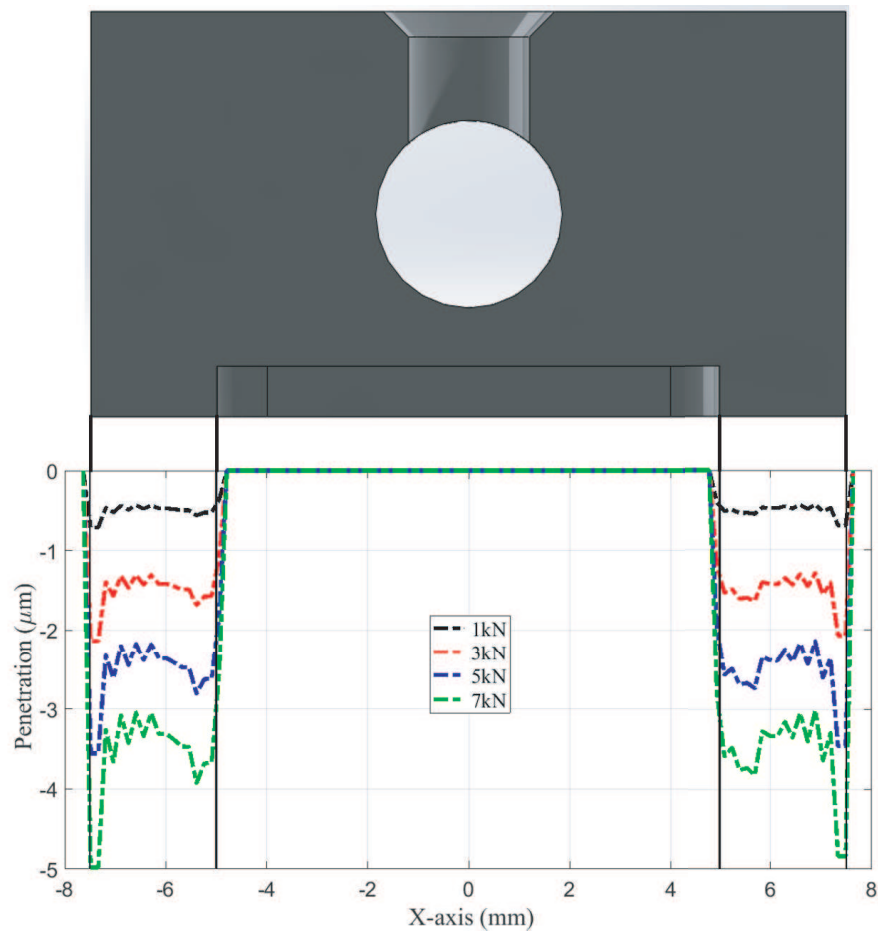

Figure 3. Penetration evolution versus normal force for hollowed-out profile (cross-sectional view).

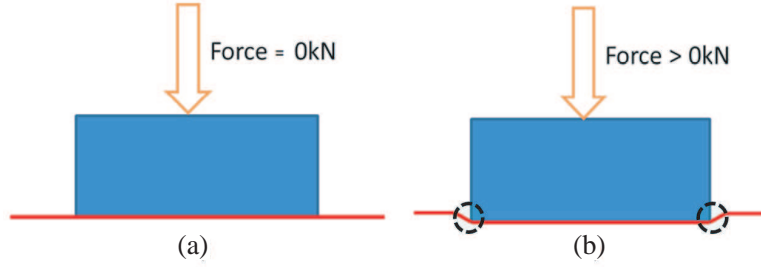

Figure 4. Synoptic of brass block penetration into aluminium ground plane for normal force (a) at 0 kN, (b) higher than 0 kN.

Table 1. Penetration area at 7 kN as a function of mechanical design and contact area obtained with simulated data coming from ANSYS Mechanical [10].

Mechanical Design	Contact area (mm ²)	Penetration area at 7 kN (mm ²)	Ratio (%)
Hollowed-out block	45	57.8	128.4
Hollowed-out block	60	71	118.3
Grooves block	45	48.8	108.4
Grooves block	60	67.1	111.8

3. INVESTIGATIONS OF PIM LEVEL EVOLUTION VERSUS CONTACT SURFACE SHAPE

As described in [7], PIM trend was defined by 10 test setup measurements. For normal force from 0.5 to 7 kN with a step of 0.5 kN, a measurement campaign depicts 140 measurements for each contact shape. Figures 5 and 6 plot the measured average, 68% confidence interval, and standard deviation of passive intermodulation level versus normal forces for both geometric surface profile at, respectively, 60 mm² and 45 mm².

3.1. Surface Profile Influence

For 60 mm² contact area, Figure 5 shows the first trend, for normal forces from 1 kN to 4 kN, wherein PIM average levels of both profiles decrease. Taking into account that 68% confidence intervals of both profiles are crossed each other, it has been observed that PIM levels of hollowed-out and grooves profiles are statistically close. Regarding standard deviations, both profiles are higher than 10 dB which means a high variation of PIM levels. The second trend has been observed, for normal forces from 4.5 kN to 7 kN, wherein PIM level average of grooves profile is around -130 dBm while the hollowed-out profile is around -125 dBm. Moreover, the standard deviation of grooves profile is lower than that of hollowed-out profile. It means a better PIM level stabilization for 60 mm² grooves profile at these normal forces.

According to Figure 6, the first trend has been observed for 45 mm² contact area. For normal forces from 0.5 to 4.5 kN, average PIM levels of the two profiles are close. Moreover, PIM levels are highly variable as standard deviations are higher than 15 dB. The second trend is observed for normal forces from 5 kN to 7 kN wherein average PIM level of grooves profile is lower than that of hollowed-out profile. The average PIM level of the grooves profile decreases from -130 dBm at 5 kN to the noise floor level at 7 kN, while average PIM level of hollowed-out profile increases to -105.8 dBm at 7 kN.

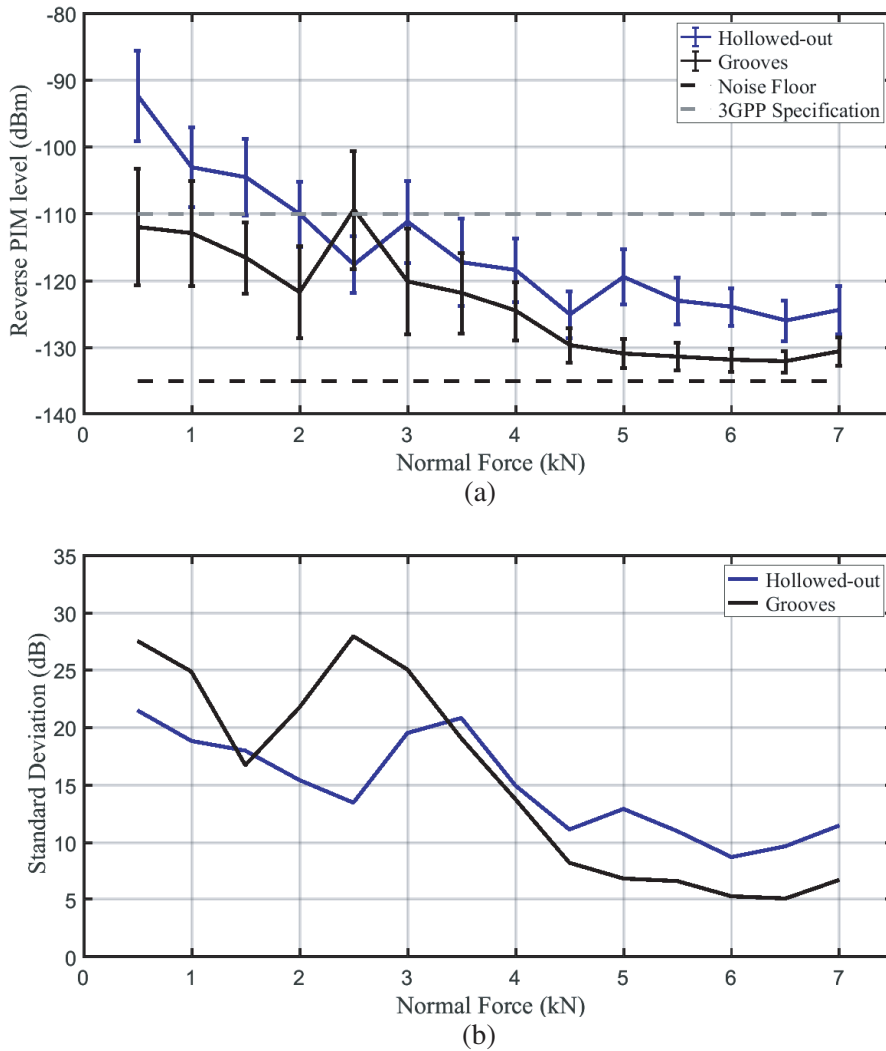

Figure 5. Comparison between hollowed-out and grooves surface profile of PIM measurements as a function of normal force for 60 mm² contact area. (a) Average and 68% confidence interval. (b) Standard deviation.

3.2. Contact Area Influence

The comparison between results for grooves profile with 45 mm² and 60 mm² areas shows a similar decreasing trend while normal force increases. Both areas reach a stabilized PIM level less than -130 dBm at 5 kN. The comparison between both contact areas of hollowed-out profile shows a similar decrease for normal forces from 0.5 to 5 kN. Nevertheless, for normal forces from 5.5 kN to 7.5 kN, the average PIM level for 60 mm² contact area is stabilized and close to -125 dBm while the average PIM level for 45 mm² contact area increases to -105.8 dBm at 7 kN with a standard deviation higher than 20 dB. According to these observations, no relationship common for both contact geometric profiles can be observed.

3.3. Comparison between PIM Level and Penetration Area at 7 kN

Focusing on average PIM level obtained at 7 kN and ratio between ground plane penetration area and contact area, a correlation appears between these parameters. In fact, at 7 kN, grooves profile achieves average PIM level at -133.4 dBm with a ratio of 108.4% for 45 mm² contact area and -130.6 dBm with

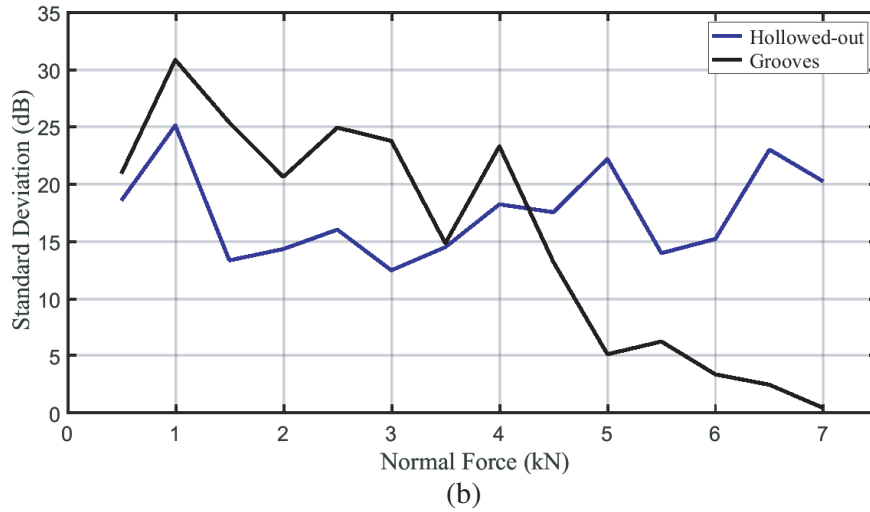
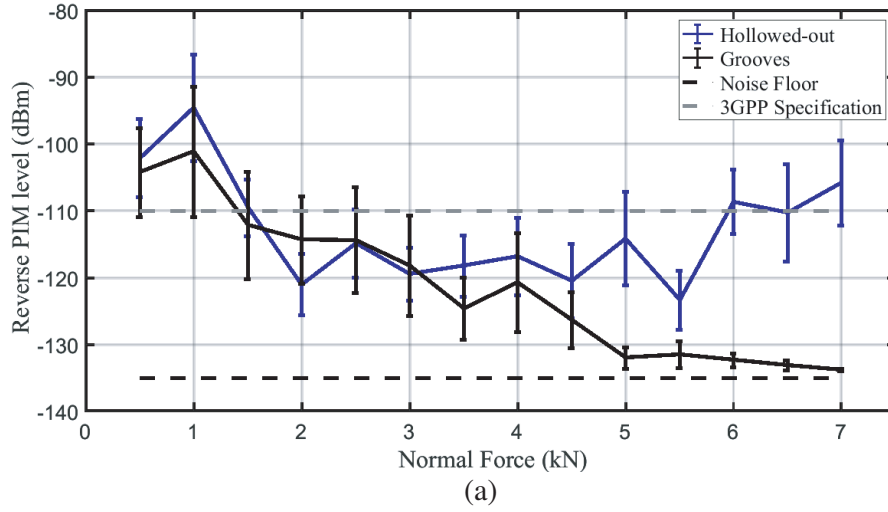

Figure 6. Comparison between hollowed-out and grooves surface profile of PIM measurements as a function of normal force for 45 mm^2 contact area. (a) Average and 68% confidence interval. (b) Standard deviation.

a ratio of 111.8% for 60 mm^2 contact area. At the same normal force, the average PIM level of hollowed-out profile reaches -124.4 dBm with a ratio of 118.3% for 60 mm^2 contact area and -105.8 dBm with a ratio of 128.5% for 45 mm^2 contact area. According to Figure 7, the correlation between penetration area and PIM level is quasi-linear. The linear model depicted in Figure 7, under the study contact conditions, is defined by Equation (2) and provides a coefficient of determination R^2 equal to 0.973. This relationship can be explained by metal-to-metal edge contact creation. In fact, the normal force applied to edge contact is very low which induces a high PIM level coming from this contact part. Consequently, the PIM level of contact between brass blocks and aluminium ground plane increases.

Therefore, to enhance the PIM level of metal-to-metal contact, it is necessary to define a contact shape which permits to reach a low penetration area.

$$PIM_{\text{dBm}} = 139 \times \frac{\text{Penetration Area}}{\text{Contact Area}} - 286 \quad (2)$$

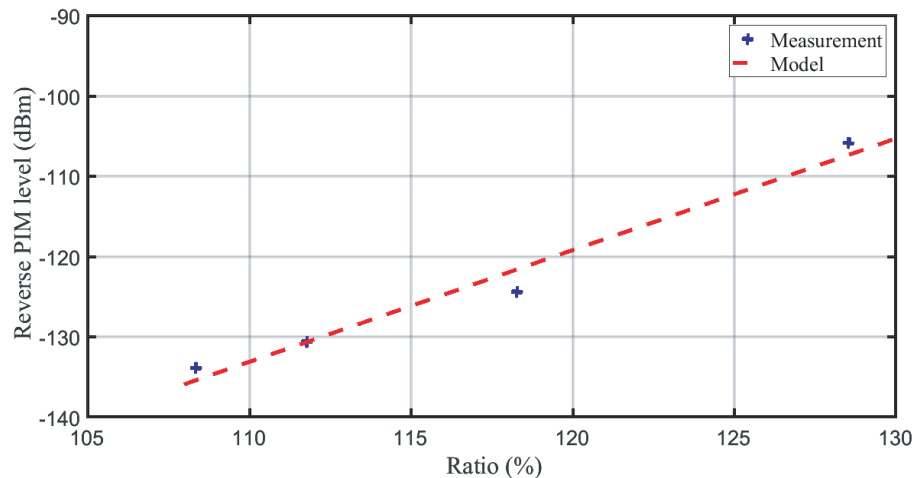

Figure 7. Average PIM level at 7 kN in function of the ratio between penetration and contact areas.

4. CONCLUSION

In this paper, we provide experimental results of passive intermodulation led by metal-to-metal contact for different contact shapes. For low normal forces, the surface profile and contact area have poor influence. For the same contact area, a difference between grooves and hollowed-out profiles appears for normal force around 5 kN. Starting from this force, it appears that grooves profile reaches a more stabilized and lower PIM level than hollowed-out profile. Moreover, the comparison between PIM trends of different contact areas with same geometric profile does not show a common relationship. Nevertheless, the comparison between mechanical simulation and PIM level averages at 7 kN shows a quasi-linear correlation between PIM level and the ratio of penetration area to contact area. Indeed, a contact shape which has lower penetration provides a lower PIM level than a contact shape with higher penetration.

In the aim to improve the antenna PIM level, additionally to proposals done in [7], metal-to-metal contact shapes must achieve a penetration area close to contact area at the normal force defined.

ACKNOWLEDGMENT

The authors are grateful to Xavier Morvan, of Institute of Electronics and Telecommunications of Rennes, for his participation in designing and manufacturing the test bench used in this article. Moreover, authors are grateful to Gaëtan Fauquert and Julien Touchet, of Radio Frequency Systems, for their help in the mechanical simulations.

REFERENCES

1. Lui, P. L., "Passive Intermodulation interference in communication systems," *Electron Electronics & Communication Engineering Journal*, Vol. 2, No. 3, 109–118, June 1990.
2. Best, G., "Passive Intermodulation (PIM) in broadcast transmission systems-lessons learned and a look into the future," *2014 IEEE International Symposium Broadband Multimedia Systems and Broadcasting (BMSB)*, June 25–27, 2014.
3. El Banna, B., T. Olsson, and J. Uddin, "Sources of passive intermodulation in base station antenna systems," *Proc. Antennas Propag. Conf.*, 139–144, Loughborough, UK, 2006.
4. *Passive Intermodulation (PIM) handling for Base Stations (BS)*, 3GPP TR 37.808, 2013.

5. Bayrak, M. and F. A. Benson, "Intermodulation products from nonlinearities in transmission lines and connectors at microwave frequencies," *Proc. Inst. Elect. Eng.*, Vol. 122, No. 4, 361–367, Apr. 1975.
6. Arazm, F. and F. A. Benson, "Nonlinearities in metal contacts at microwave frequencies," *IEEE Trans. Electromagn. Compat.*, Vol. 3, 142–149, Aug. 1980.
7. Duteil, G., F. Colombel, S. Avrillon, P. Le Cam, and J. P. Harel, "Experimental studies of passive intermodulation in metal-to-metal contacts," *Progress In Electromagnetics Research M*, Vol. 60, 67–73, 2017.
8. Vincente, C., D. Wolk, H. L. Hartnagel, B. Gimeno, V. E. Boria, and D. Raboso, "Experimental analysis of passive intermodulation at waveguide flange bolted connections," *IEEE Trans. on Microwave Theory and Techniques*, Vol. 55, No. 5, May 2007.
9. *Geometrical Product Specifications (GPS) — Surface Texture: Profile Method — Terms, Definitions and Surface Texture Parameters*, ISO-4287, 1997.
10. Mechanical, ANSYS, Release 14.0, ANSYS, 2009.