

Shielding Effectiveness of a Metamaterial Measured at Microwave Range of Frequency, Known as Wire Screen Metamaterial (WSM)

Silvina Boggi^{1, 2, *}, Ramiro Alonso¹, and Walter G. Fano¹

Abstract—This paper presents the study of an artificial material, made up of a periodic structure, defined by a unit cell, consisting of a finite number N of periodic layers of thin conducting cylinders placed between two dielectric planes. These artificial materials known as metamaterials can be regarded as a homogeneous material with effective constitutive parameters impossible to achieve with naturally occurring materials, such as negative values for both magnetic permeability and electric permittivity. An analytical model has been developed to study the effective electric permittivity of the whole system in terms of the unit cell dimensions and the frequency of the incident electromagnetic wave. Simulations of the effective electric permittivity of the metamaterial were performed by varying the geometry of the metamaterial. This analysis enables the design and construction of structures with properties that make them an attractive candidate for shielding applications in the range of microwave frequencies. The metamaterial has been constructed with four rows of 5 bronze conducting rods each. We have made experimental measurements of the shielding effectiveness of these materials when subjected to a electromagnetic plane wave with electric field polarized along the direction of the conducting rods, and conversely, with electric field polarized perpendicular to the rods. Non-zero values for shielding effectiveness were observed in the first polarization, and zero values in the second case.

1. INTRODUCTION

The first attempt to explore the concept of artificial materials and chiral media was made by Jagadis Chunder Bose with his microwave experiments in 1898. In 1914, Lindman worked on artificial chiral media, which consisted of metallic helix in a dielectric [1]. In 1948, Kock made lightweight microwave lenses from a set of conducting spheres, disks, and strips periodically arranged, adjusting the effective refracting index of the artificial material [4, 5].

In 1967, Viktor Veselago [6] proposed the existence of substances which support electromagnetic propagation where the electric field vector \mathbf{E} , the magnetic field vector \mathbf{H} , and the propagation vector form a left-handed (LH) triplet, as compared to conventional materials, which form right-handed (RH) triplet.

It was almost 30 years after Veselago's paper when the first LH material was conceived and experimentally demonstrated. These LH materials are not natural as Veselago imagined, but have an effective homogeneous structure, as Smith and other researchers have proposed [1].

This structure was inspired by the pioneering works of Pendry at Imperial College, London. Pendry introduced the plasmonic-type negative- ϵ positive- μ and positive- ϵ negative- μ structures which can be designed to have their plasmonic frequency in the microwave range [2].

Received 6 September 2017, Accepted 2 November 2017, Scheduled 2 December 2017

* Corresponding author: Silvina Boggi (silvinaboggi@gmail.com).

¹ Radiation Laboratory, Faculty of Engineering, University of Buenos Aires, Argentina. ² Department of Mathematics, Faculty of Engineering, University of Buenos Aires, Argentina.

These materials known as metamaterials consist of periodic structures defined by a unit cell of a characteristic size. Applying the quasi-static approximation, the cell size for the system's effective response to electromagnetic radiation is [3, 7, 8]:

$$a \ll \lambda = \frac{c_0}{f} \quad (1)$$

where f is the electromagnetic wave frequency, c_0 the light velocity in vacuum, and a the characteristic cell size. In other words, the spatial size of this cell must be small compared to the wavelength of the electromagnetic field which is propagating [8].

As the wavelength of the radiation is much larger than the cell unit length, this radiation is unable to detect the internal structure, and at this point, these artificial materials can be regarded as a homogeneous material with effective constitutive parameters [7] which will depend upon the contents of the cell.

Metamaterials have a wide range of potential applications in the optical and microwave field, such as new types of modulation systems, transition frequency band filters, microwave couplers, absorbers, antennas, and electromagnetic wave shielding [12, 14, 15].

The plane-wave shielding effectiveness of a planar-mesh screen and its applicability to the measurement of mesh properties has been carried out in [9].

The analysis of the effective permittivity of the metamaterial developed in this work considers the work of Pendry [8], in which the average magnetic and electric fields are defined, and the effective permeability of the metamaterials screen is obtained.

The shielding performance of a planar metamaterial wire medium screen under plane-wave illumination in the low frequency range with the electric field polarized along the wire direction has been studied in [13].

This artificial material (metamaterial) can offer advantages over conventional metallic screens used for electromagnetic wave shielding purposes, given its low density and weight saving, when a polarized uniform plane wave propagates along the material, possibly showing other selective properties [13].

2. THE EFFECTIVE ELECTRIC PERMITTIVITY MODEL OF THE WSM METAMATERIAL (WIRE SCREEN METAMATERIAL)

The WSM system made by array of cylindrical conductors placed between two insulating plates separated by a distance d was considered as a capacitor subjected to the external electric field (\vec{E}) parallel to the rods axis (z axis) as shown in Fig. 1.

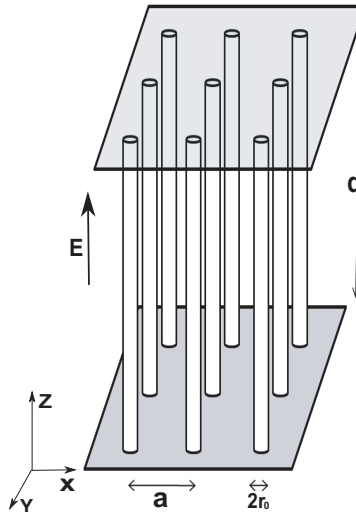

Figure 1. The rods screen metamaterial is made of bronze rods of radius r_0 and separation between rods a .

The contents of the cell will define the system's effective response as a whole:

$$\vec{D} = \epsilon_0 \epsilon_{eff} \vec{E} \quad (2)$$

where \vec{D} is the electric displacement vector, \vec{E} the electric field vector of the incident wave, and ϵ_{eff} the effective electric permittivity.

The relationship between the electric displacement \vec{D} , the electric field vector \vec{E} and the polarization inside a medium \vec{P} [19] is:

$$\vec{D} = \epsilon_0 \vec{E} + \vec{P} \quad (3)$$

In this case:

$$\vec{D} = \epsilon_0 \vec{E} + \frac{\vec{J}}{j\omega} \quad (4)$$

where \vec{J} is the current density flowing through the conducting wires and ω the angular frequency of the electromagnetic wave.

$$\vec{D} = \epsilon_0 \vec{E} + \hat{z} \frac{I}{j\omega a^2} \quad (5)$$

where a is the characteristic size of the system and I the electric current flowing through the conductors.

Considering the unit cell's inductance per unit length L , including the mutual coupling between conductors, and taking into account that conductors have electric losses due to Joule heating::

$$E = j\omega LI + Z_{int} I \quad (6)$$

where Z_{int} is the internal impedance of the cylindrical conductors. Solving for I of Eq. (6) and replacing it in Eq. (5):

$$\vec{D} = \epsilon_0 \vec{E} + \frac{\vec{E}}{j\omega a^2 (j\omega L + Z_{int})} \quad (7)$$

The effective electric permittivity of the metamaterial results:

$$\epsilon_{eff} = \epsilon_0 + \frac{1}{j\omega a^2 (j\omega L + Z_{int})} \quad (8)$$

Admitting that there is a series capacitance of the system owing to the cylindrical conductors, since most systems are resonant due to an internal inductance and a capacitance [8], a term is added to the effective relative electric permittivity:

$$\epsilon_{effr} = 1 + \frac{1}{\epsilon_0 j\omega a^2 (j\omega L + \frac{1}{j\omega C} + Z_{int})} \quad (9)$$

where C is the capacitance of the system.

With:

$$Z_{int} = \frac{1}{2\pi r_0} \sqrt{\frac{j\omega\mu}{\sigma + j\omega\epsilon}} \left(\frac{I_0(\gamma \cdot r_0)}{I_1(\gamma \cdot r_0)} \right) \quad (10)$$

where I_0 and I_1 are Bessel functions; γ is propagation constant; σ , ϵ and μ are the electric and magnetic properties of the conducting wire.

$$L = \frac{\mu_0}{2\pi} \ln \frac{a^2}{4r_0(a - r_0)} \quad (11)$$

where r_0 is the radius of the conducting wires.

In the appendixes, the inductance L and the conductors impedance Z_{int} are calculated.

A simulation of the effective permittivity of the metamaterial as a function of frequency was performed for different conductors' radii and cell sizes applying the previous model of Eq. (9) to determine the convenient geometry for the fabrication of the prototype according to its resonance frequency in microwave band of frequency [16]. In Appendix C, some of these simulations are shown.

The real part of the effective electrical permittivity as a function of frequency for the metamaterial builded can be observed in Fig. 2; the conducting cylinders have a radius $r_0 = 2$ mm, and the cell size is $a = 30$ mm, $\sigma = 10^7$ S/cm, $\mu = 4\pi 10^{-7}$ H/m. In this work, a capacity of value $C = 0.5 \cdot 10^{-13}$ F has been assumed, due to the location of the peak that was obtained in previous simulation of electric permittivity work by the authors [16] and experimentally in the shielding effectiveness measurements that were performed on prototypes with aggregates of capacitors in previous works [17].

A Savitzky-Golay method [11, 10], with 6 computed points and a polynomial of degree 2 of approximation was used in the graph of Fig. 2. The Savitzky-Golay method is based on the calculation of a local polynomial regression (of degree k), with at least $k+1$ equally spaced points, to determine the new value for each point. The result will be a function similar to the input data, but smoothed. The main advantage of this approximation is that it tends to preserve the features of the initial distribution such as relative maxima and minima, and peaks width, which are generally flattened by other averaging techniques (like moving averages).

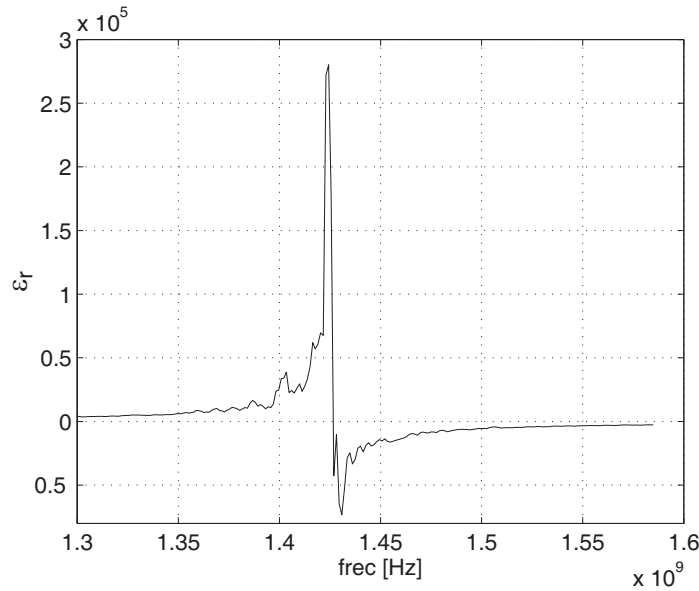

Figure 2. Simulation of the real part of the effective electrical permittivity of the metamaterial.

This simulation of the permittivity will be used in the next sections for a simple design of an efficient WSM. This permittivity is important for the shielding efficiency (SE), and in work [13] an approximation is proposed for the expression of the SE of a planar screen using permittivity models, in which it is observed that the frequency range of interest for a better SE is that in which $\epsilon_r < 0$ and $|\epsilon_r| \gg 1$. This work only uses the permittivity simulation to locate the resonance frequency and the frequency range of interest for the shielding efficiency.

3. SHIELDING EFFECTIVENESS

A shielding is, conceptually, a barrier to the transmission of electromagnetic fields. Shieldings are chosen for their physical properties (temperature resistance, weather resistance, structural resistance, weight, cost, etc.), as well as for their electric permittivity and magnetic permeability. Permittivity is a measure of the material's effect over the electric field of the electromagnetic wave, while permeability is a measure of the material's effect over the magnetic field.

When an electromagnetic plane wave is incident on a material, as shown in Fig. 3, a part of the incident wave is reflected, and the other part is transmitted along the material [18, 20, 23].

As well known, the shielding effectiveness (SE) is calculated as the ratio of the magnitude of the electric field that is incident on the material to the magnitude of the electric field that is transmitted

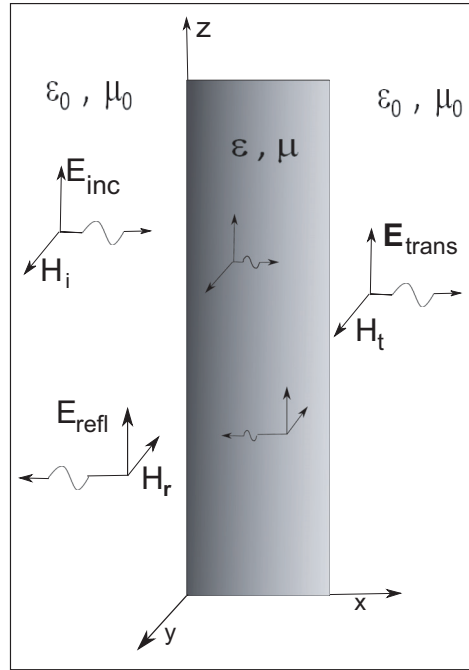

Figure 3. Illustration of the shielding effectiveness of a material subjected to a plane electromagnetic wave.

through the material.

$$SE_{(dB)} = 20 \log \left| \frac{E_{inc}}{E_{trans}} \right| \tag{12}$$

4. EXPERIMENTAL PROCEDURE

A wire screen metamaterial has been built by an array of 4 rows of 5 bronze cylinders, each of 2 millimeters radius and spaced a distance of 30 millimeters located between two dielectric planes perpendicular to the conductors.

The test bench is shown in Fig. 4 and made up of two LOG periodic antennas, for range of frequency: 800–3899 MHz, connected to an Agilent Field Fox N9932A vector network analyzer.

The antennas used for measurement and the network analyzer used are shown in Fig. 5. A plane wave is emitted through the transmitting antenna, and the distance between the antenna and the metamaterial corresponds to the far-field approximation $r > \frac{2D^2}{\lambda}$ [24, 25]. The distance between the transmitting antenna and the metamaterial and between the metamaterial and the receiving antenna was $r = 48$ cm, and the larger dimension of the transmitting antenna was $D = 14$ cm.

The metamaterial’s shield effectiveness measurement consists of sending a plane wave along the material for each bandwidth and measuring its response. Power from a transmitter is coupled to a receiver, first with no material present in order to establish a reference level, and then with the sample introduced. In each case, the source output level is kept the same. The ratio of the two received powers gives the insertion loss [26].

We measured the S_{21} coefficients, the forward transmission coefficients of the scattering matrix for a two-port network (expressed in dB). The difference between the S_{21} coefficients with and without metamaterial is as a result of the shielding effectiveness (SE).

Measurements were made with the electric field polarized in the direction parallel to the axis of the cylinders, i.e., on the z axis and also with the electric field polarized in the direction of the y axis, perpendicular to the axis of the cylinders as seen in Fig. 6(a) and Fig. 6(b), respectively.

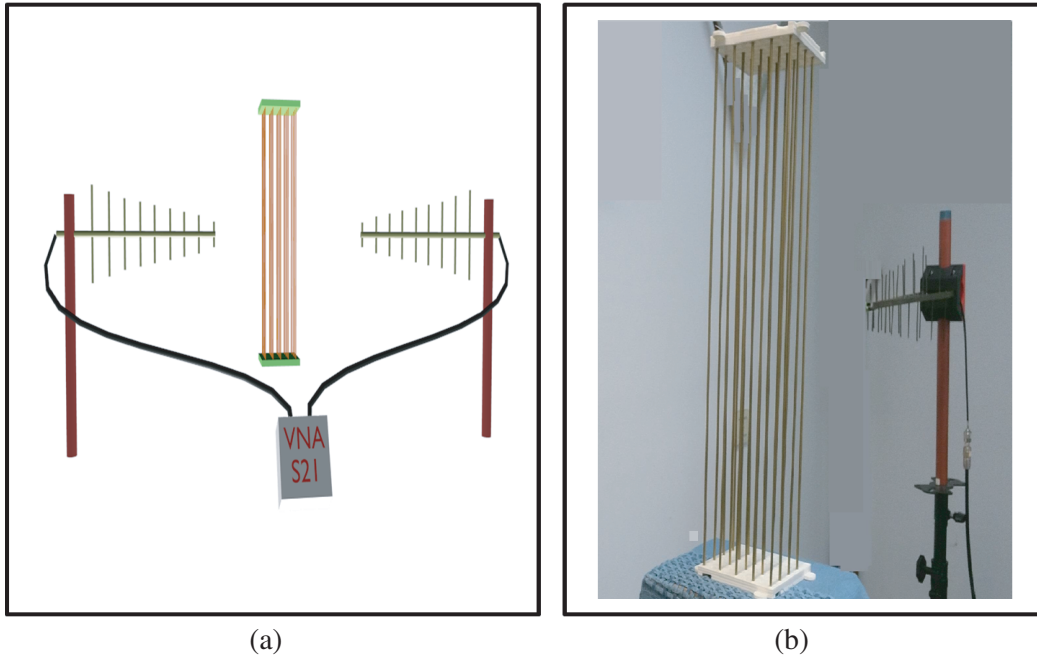

Figure 4. (a) Test bench. (b) Metamaterial and test bench.

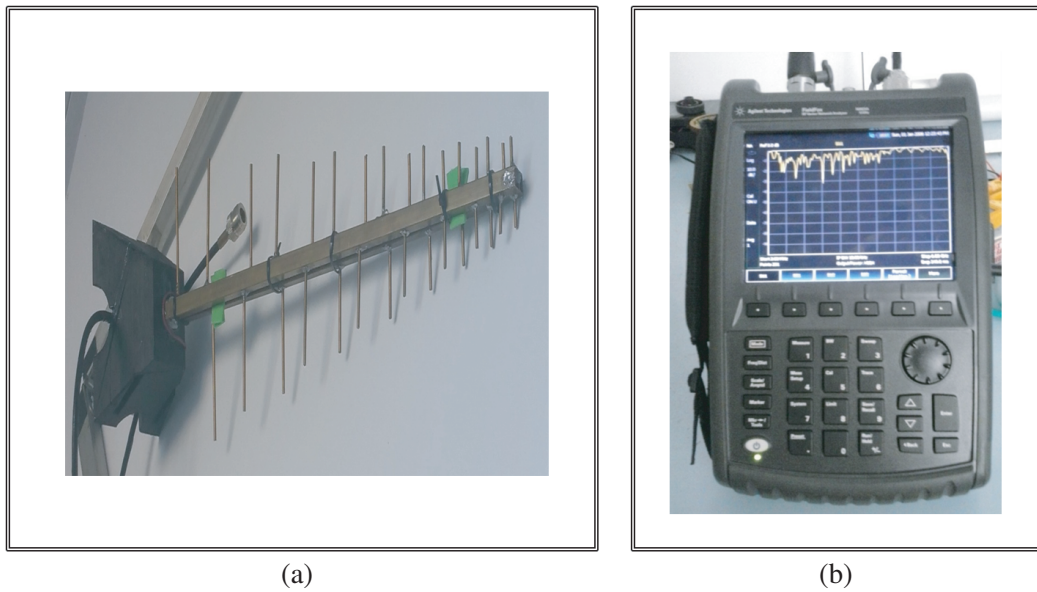

Figure 5. (a) Log periodic antenna used for measurement. (b) Picture of Network analyzer (VNA).

The calibration of the network analyzer is important in order to ensure a reliable measurement [21, 22].

5. RESULTS

Fig. 7 shows the shielding effectiveness for the metamaterial under test, with the application of an electromagnetic plane wave with electric field polarized along the direction of the z axis, parallel to the

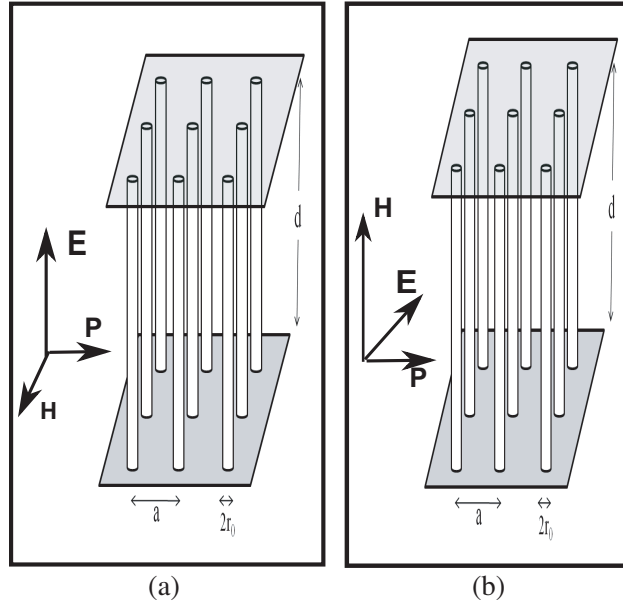

Figure 6. (a) Polarized in the direction parallel to the cylinders. (b) Polarized in the direction perpendicular to the axis of the cylinders.

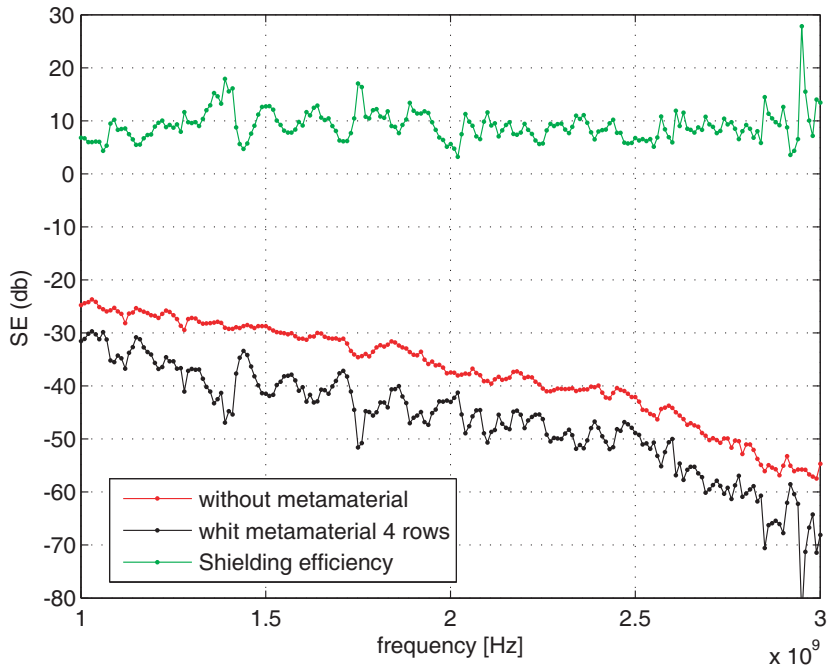

Figure 7. Shielding efficiency of metamaterial with 4 rows.

cylinders axis, at a frequency range of 1000–3000 MHz. A significant shielding effectiveness is observed for the metamaterial across the entire bandwidth.

Fig. 8 shows the shielding effectiveness for the metamaterial under test, with the application of an electromagnetic plane wave with electric field polarized along the direction of the z axis, parallel to the cylinders axis, at a frequency range of 1000 to 1500 MHz. As expected from the model, the shielding effectiveness increases at frequencies near 1.4 GHz, and then, there is a decrease, which is consistent with the graph in Fig. 2 since the peak of permittivity and the negative values of permittivity are observed

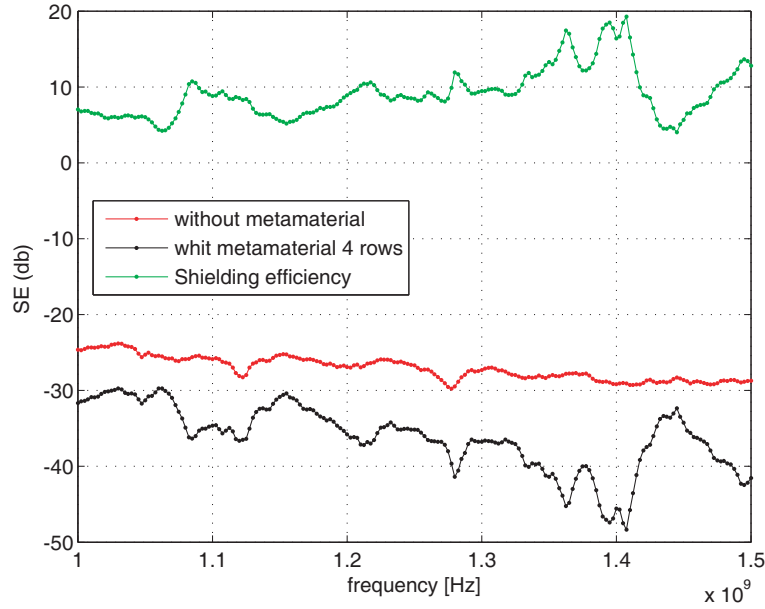

Figure 8. Shielding efficiency of metamaterial with 4 rows, frequency range 1000–1500 MHz.

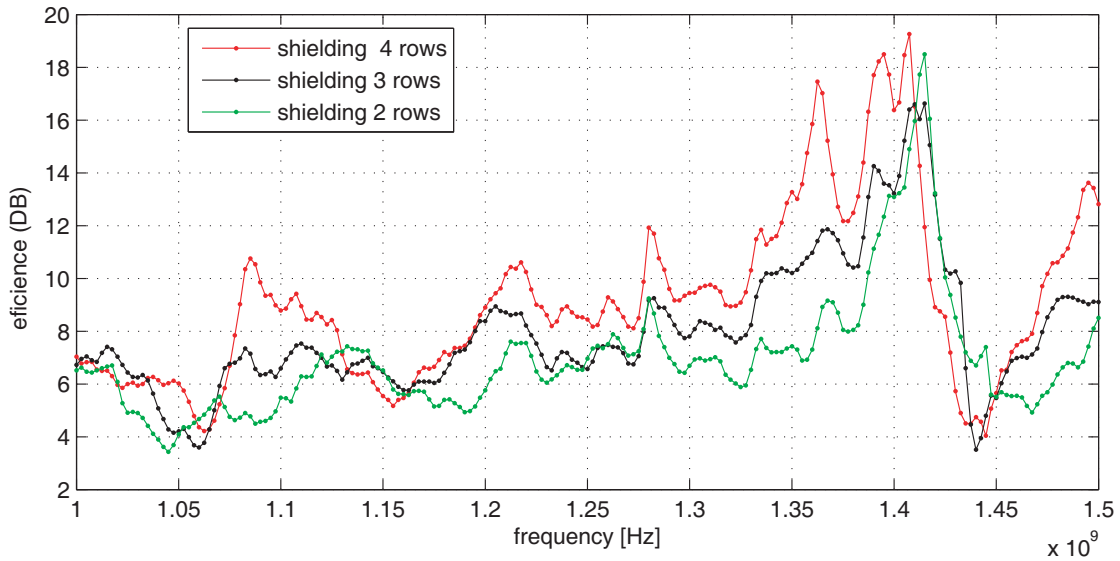

Figure 9. Shielding Efficiency of Metamaterial with 4 rows, 3 rows and 2 rows.

around these frequencies.

Figure 9 shows the shielding effectiveness at a frequency range of 1000 to 1500 MHz for the metamaterial with a different numbers of rows of wires. It can be seen that, as the shielding theory points out, as the numbers of rows of wires increase, namely, as the wall thickness of the material increases, the shielding effectiveness increases as well.

In Fig. 10, the effectiveness of a metamaterial subjected to an electromagnetic plane wave with electric field polarized in y -direction, that is to say in a horizontal direction, perpendicular to the wires axis. Fig. 10(a) shows the band of frequencies ranging from 450–900 MHz, and Fig. 10(b) the band of frequencies ranging from 800–3800 MHz. At both frequency bands, the effectiveness was found to be practically null. This shows that a plane wave normally incident to the wires axis would not be affected

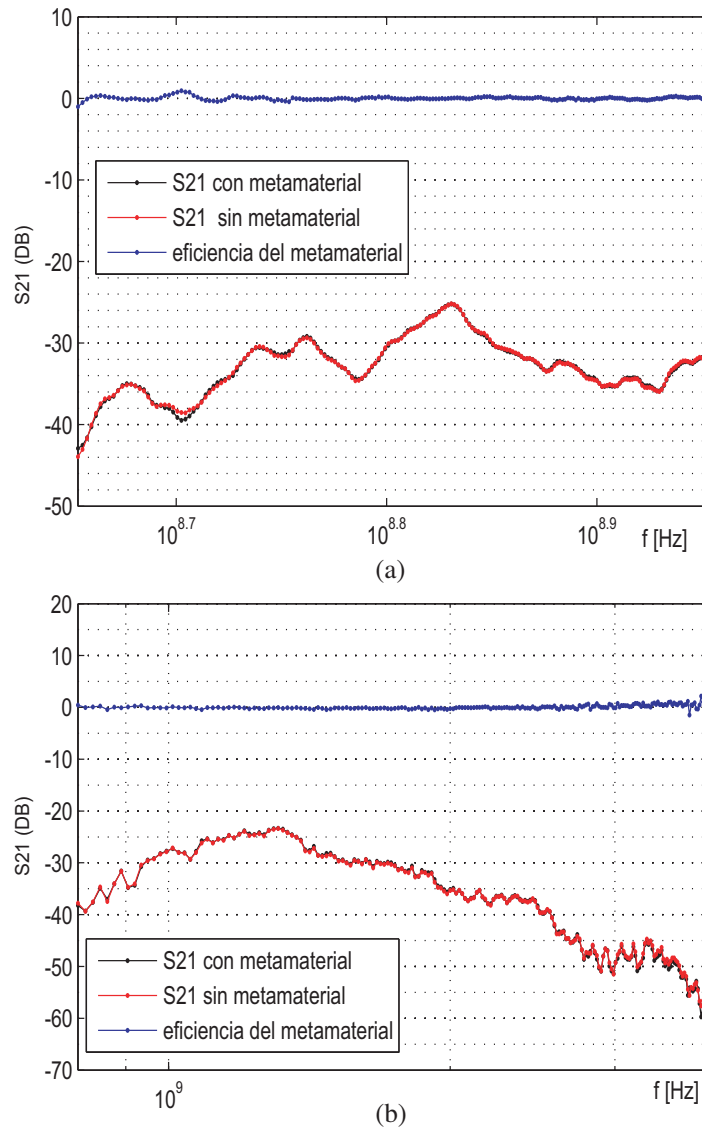

Figure 10. Shielding effectiveness of the metamaterial subjected to an electric field polarized in horizontal direction (a) at the frequency range of 450–900 MHz, (b) at the frequency range of 800–3800 MHz.

by the conductors presence and would simply see a screen with the same relative permittivity of free space [13, 16].

The test measurements were also made with 2 loops antennas placed on the sides of the metamaterial and connected to the vector network analyzer, but the sensitivity of the system was poor and the noise significant; therefore, the results of those measurements will not be shared here.

6. CONCLUSIONS

In this work, a wire screen metamaterial has been built, a simulation has been performed of the electric permittivity of a material made up of a periodic structure, defined by a unit cell, consisting of an array of bronze rods placed between two dielectric planes as a function of frequency. These materials known as metamaterials have an effective homogeneous structure impossible to achieve with natural materials, such as negative values for both magnetic permeability and electric permittivity.

A structure with a resonance frequency around 1.4 GHz was chosen for its subsequent construction.

This material was fabricated with four rows of 5 bronze conducting wires each. Experimental measurements were made on the shielding effectiveness of this material when subjected to a plane electromagnetic wave with the electric field polarized along the conducting wires direction, and, conversely, with the electric field polarized perpendicular to the wires at a frequency range of 1000 MHz to 3000 MHz; non-zero values of shielding effectiveness were observed in the first polarization and zero values in the second.

It was found that this metamaterial's effectiveness is between 10 and 20 decibels, reaching a maximum value at frequencies near 1.4 GHz. As predicted from the model, the shielding effectiveness increases at frequencies of around 1.4 GHz, and then, there is a decrease, which is consistent with the proposed permittivity model, since high values of permittivity are observed at around those frequencies, and negative values of permittivity at slightly higher frequencies.

ACKNOWLEDGMENT

This work was carried out thanks to the Department of Electronics of the Faculty of Engineering at the University of Buenos Aires who provided the required equipment. We would also like to thank Miss Marcela Luberto for her collaboration in the WSM metamaterial construction.

APPENDIX A. CALCULATION OF THE INDUCTANCE PER UNIT LENGTH IN THE SPACE BETWEEN CONDUCTORS

The inductance per unit length inside the metamaterial is calculated due to the magnetic field flux in the space between conductors, see Fig. A1

$$L = \frac{\Psi}{I} \quad (\text{A1})$$

where Ψ is the magnetic field flux per unit length, given by:

$$\Psi = \mu_0 \int H_y dx \quad (\text{A2})$$

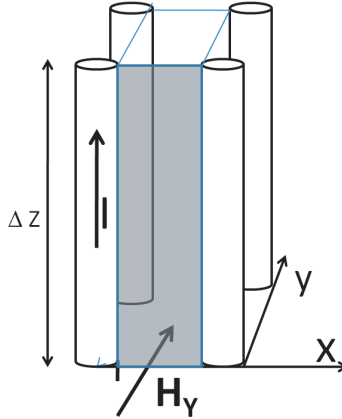

Figure A1. Picture of the WSM cell for the calculation of the inductance of the system.

Taking into account that, due to the symmetry of the problem, the magnetic field is zero at the middle points between conductors, and the main contribution to the flux comes from the area near the conductors. We are led to the following estimation for two neighboring conductors:

$$H_Y = \frac{I}{2\pi} \left(\frac{1}{x} - \frac{1}{a-x} \right) \quad (\text{A3})$$

The first term is the quasi-static field generated by the conductor at $x = 0$, and the second term is the field generated by the neighboring conductor, which is included so that the total field is zero in the center of symmetry. The magnetic flux per unit length obtained is:

$$\Psi = \mu_0 \frac{I}{2\pi} \int_{r_0}^{a/2} \left(\frac{1}{x} - \frac{1}{a-x} \right) dx \quad (\text{A4})$$

Therefore, the inductance is given by:

$$L = \frac{\mu_0}{2\pi} \ln \frac{a^2}{4r_0(a-r_0)} \quad (\text{A5})$$

where r_0 is the radius of the conducting wires.

APPENDIX B. ELECTRIC FIELD IN THE CONDUCTOR. CURRENT DENSITY. INTERNAL IMPEDANCE

In order to calculate the electric field in the cylindrical conductor, the Maxwell equations are applied:

$$\nabla \times \vec{E} = -j\omega\mu\vec{H} \quad (\text{B1})$$

$$\nabla \times \vec{H} = (\sigma + j\omega\epsilon)\vec{E} \quad (\text{B2})$$

Doing the calculations for a cylindrical geometry and given the symmetry of the system, we can say that:

$$\begin{aligned} \frac{\partial E}{\partial \phi} &= 0 \\ \frac{\partial E}{\partial z} &= 0 \end{aligned} \quad (\text{B3})$$

Consider that the electric field and external magnetic field applied to the metamaterial and the conductors are given by:

$$\begin{aligned} E &= E_z \\ H &= H_\phi \end{aligned} \quad (\text{B4})$$

We get the second order differential equation, from which the field E_z can be obtained [20].

$$\frac{\partial^2 E_z}{\partial(\gamma\rho)^2} + \frac{1}{\gamma\rho} \frac{\partial E_z}{\partial(\gamma\rho)} - E_z = 0 \quad (\text{B5})$$

where γ is the propagation constant:

$$\gamma = \sqrt{j\omega\mu(\sigma + j\omega\epsilon)} \quad (\text{B6})$$

Equation (B5) is called Bessel's modified differential equation, with the following results:

$$E_z = AI_0(\gamma\rho) + BK_0(\gamma\rho) \quad (\text{B7})$$

for $\rho \rightarrow 0 \Rightarrow K_0(\gamma\rho) \rightarrow \infty$, then $B = 0$

Therefore, the electric field will be:

$$E_z = AI_0(\gamma\rho) \quad (\text{B8})$$

Similarly, H_ϕ is obtained from Maxwell Equation:

$$H_\phi = \frac{1}{j\omega\mu} \frac{\partial E_z}{\partial \rho} = \frac{\gamma AI_1(\gamma\rho)}{j\omega\mu} \quad (\text{B9})$$

The internal impedance per unit length in the conducting wire is defined as [20]:

$$Z_{int} = \frac{E_z(r_0)}{I} \quad (\text{B10})$$

where, following Ampere's Law, the total current traveling along the conductor is:

$$I = 2\pi r_0 H_\phi \quad (\text{B11})$$

Replacing Eq. (B11) in Eq. (B10), we obtain the internal impedance in a conducting wire.

$$Z_{int} = \frac{AI_0(\gamma\rho)}{2\pi r_0 H_\phi} \quad (\text{B12})$$

Replacing the magnetic field H from Eq. (B9), we obtain:

$$Z_{int} = \frac{AI_0(\gamma\rho)}{2\pi r_0 \frac{\gamma AI_1(\gamma\rho)}{j\omega\mu}} \quad (\text{B13})$$

Replacing γ from Eq. (B6), we obtain:

$$Z_{int} = \frac{1}{2\pi r_0} \sqrt{\frac{j\omega\mu}{\sigma + j\omega\epsilon}} \left(\frac{I_0(\gamma \cdot r_0)}{I_1(\gamma \cdot r_0)} \right) \quad (\text{B14})$$

where I_0 and I_1 are Bessel functions, and σ , ϵ and μ are the electric and magnetic properties of the conducting wire.

Figure B1 shows the internal impedance of the conducting wire as a function of its radius.

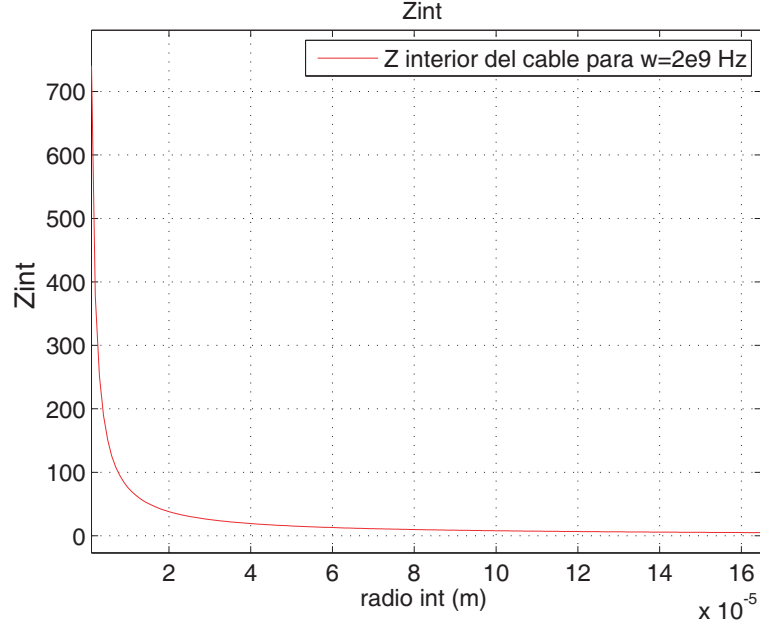

Figure B1. Internal impedance of the cylindrical conductor as a function of radius, for the frequency $f = 2 \cdot 10^9$ Hz.

APPENDIX C. SIMULATION OF THE EFFECTIVE PERMITTIVITY

Simulation of the effective permittivity of the metamaterial as a function of frequency was performed for different conductor radii and cell sizes applying the previous model [16].

Fig. C1 shows the simulation of the effective electric permittivity as a function of the frequency for different radii of the rods considering constant cell size $a = 30$ mm. It can be seen that as the radius increases the resonance frequency increases.

The effective electric permittivity of the metamaterial was simulated as a function of the frequency for different cell sizes a , considering the constant conductor radius $r_0 = 2 \cdot 10^{-3}$ m. The result is observed in Fig. C2. It can be seen that as the distance a between rods increases, the resonance frequency of the metamaterial decreases.

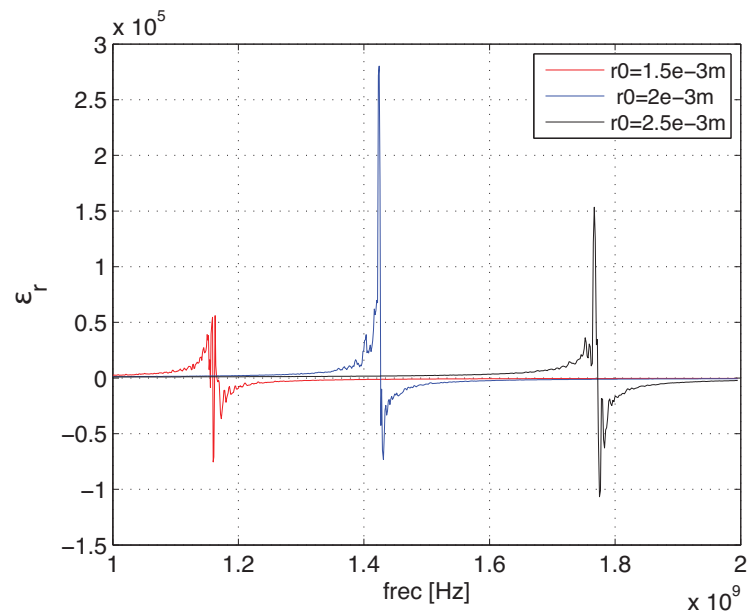

Figure C1. Effective electric permittivity as a function of frequency for different radii.

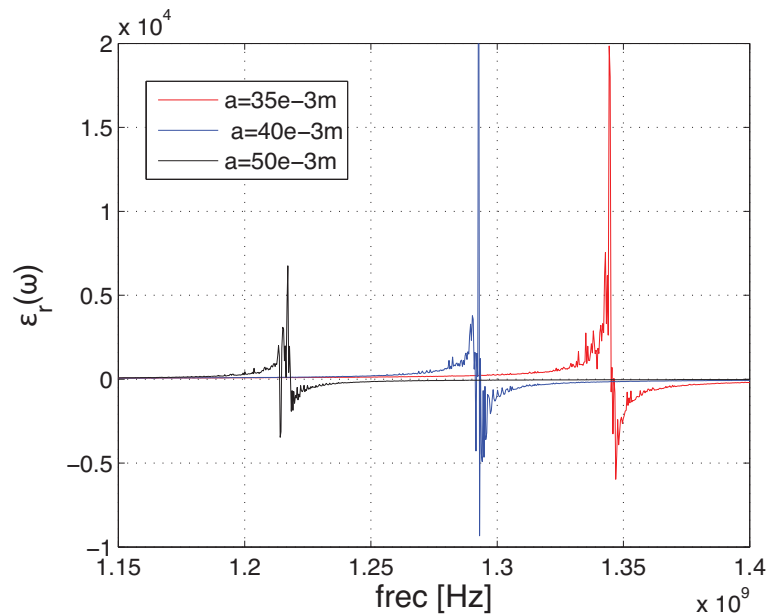

Figure C2. The effective electric permittivity of the metamaterial as a function of the frequency for different cell sizes.

REFERENCES

1. Engheta, N., *Metamaterials Physics and Engineering Explorations*, IEEE Press, USA, 2006.
2. Caloz, C. and T. Itoh, *Electromagnetic Metamaterials: Transmission Line Theory and Microwave Applications*, Published by John Wiley and Sons, Inc., Hoboken, New Jersey, 2006.
3. Pendry, J. B., “Metamaterials and the control of electromagnetic fields,” *Conference on Coherence and Quantum Optics, OSA Technical Digest (CD)*, Optical Society of America, 2007.

4. Kock, W. E., "Radio lenses," *Bell Lab. Rec.*, Vol. 24, 177–216, 1946.
5. Collin, R., *Field Theory of Guided Waves*, McGraw Hill, USA, 1960.
6. Veselago, V. G., "The electrodynamics of substances with simultaneously negative values of ϵ and μ ," *Sov. Phys. Usp.*, Vol. 10, No. 4, 509–514, 1967.
7. Maslovski, S. I., S. A. Tretyakov, and P. A. Belov, "Wire media with negative effective permittivity a quasi-static model," *Modelmicrowave and Optical Technology and Optical Letters*, Vol. 35, 1, páginas, Oct. 5, 2000.
8. Pendry, J. B., A. J. Holden, D. J. Ronbinson, and W. J. Stewart, "Magnetism from conductors and Enhanced Nonlinear Phenomena," *IEEE Trans. on MTT*, Vol. 47, 11, páginas, Feb. 1999.
9. Casey, K. F., "Electromagnetic shielding behavior of wire-mesh screens," *IEEE Transactions on Electromagnetic Compatibility*, Vol. 30, No. 3, Aug. 1988.
10. Press, W. H., B. P. Flannery, S. A. Teukolsky, and W. T. Vetterling, *Numerical Recipes in C: The Art of Scientific Computing*, Cambridge University Press, 1992.
11. Surhone, L. M., M. T. Timpledon, and S. F. Marseken Savitzky-Golay, *Savitzky-Golay Smoothing Filter*, 116 pages, VDM Publishing, Aug. 10, 2010.
12. Rahman, M. and M. A. Stuchly, "Transmission line periodic circuit representation of planar microwave photonic bandgap structures," *Microwave and Optical Tech. Lett.*, Vol. 30, No. 1, 15–19, 2001.
13. Lovat, G., P. Burghiognoli, and S. Celozzi, "Shielding properties of a wire medium screen," *IEEE Trans. on EMC*, Vol. 50, 1, páginas, Feb. 2008.
14. Yang, F. and Y. Rahmat-Samii, *Electromagnetic Band Gap Structures in Antenna Engineering*, Cambridge University Press, UK, 2009.
15. Eleftheriades, G. V. and K. G. Balmain, *Negative-Refractive Metamaterials Fundamental Principles and Applications*, IEEE Press, USA, 2005.
16. Boggi, S., A. Kieselesky, and W. G. Fano, "A model for the effective dielectric permittivity of Metamaterials," *Proceedings of RPIC-IEEE 2015 Symposium*, Oct. 2015.
17. Boggi, S., R. Alonso, and W. G. Fano, "Eficiencia de blindaje de nuevos materiales," *Proceedings of IEEE Biennial Congress of Argentina (ARGENCON)*, 1–5, 2016.
18. Clayton, P. R., *Introduction to Electromagnetic Compatibility*, 2nd edition, Wiley Interscience, Jan. 2006.
19. Trainotti, V., W. G. Fano, and L. A. Dorado, *Ingeniería Electromagnética Tomo I*, Editorial Nueva Librería, Buenos Aires, Arg., 2003.
20. Jordan, E. J., *Electromagnetic Waves and Radiating Systems*, Wiley, USA, 1950.
21. Trainotti, V., W. G. Fano, and L. A. Dorado, *Ingeniería Electromagnética Tomo II*, Editorial Nueva Librería, Buenos Aires, Arg., 2005.
22. Pozar, D. M., *Microwave Engineering*, 4th edition, Wiley, USA, 2011.
23. Schelkunoff, S. A., *Electromagnetics Wave*, D. Van Nostrand Company, USA, Apr. 1943.
24. Balanis, C. A., *Antenna Theory: Analysis and Design*, Wiley, 2005.
25. IEEE Standard Method for Measuring the effectiveness, IEEE-Std-299-1997.
26. Wilson, P. F., "Techniques for measuring the electromagnetic shielding effectiveness of materials: Part I: Far field source simulation," *IEEE Transactions on Electromagnetic Compatibility*, Vol. 30, No. 3, Aug. 1988.