

A Comparison between Carson's Formulae and a 2D FEM Approach for the Evaluation of AC Interference Caused by Overhead Power Lines on Buried Metallic Pipelines

Andrea Cristofolini*, Arturo Popoli, and Leonardo Sandrolini

Abstract—In this paper, the AC interference produced by an overhead power transmission line on a buried metallic pipeline is estimated using a circuital method based on the well-known Carson's formulae and a two-dimensional finite element numerical code. The finite element formulation used in this paper implicitly takes into account the mutual inductive coupling between all the considered conductors, and it allows a more detailed analysis in cases where a nonhomogeneous soil is present. The FEM approach includes a procedure which has been developed to enforce that the sum of the currents flowing through the soil, pipeline and eventual overhead ground wire is equal to zero. A case study has been identified, and the results obtained by the two approaches have been compared and discussed.

1. INTRODUCTION

Whenever overhead power-lines and buried metallic pipelines share the same transport corridors, the AC nature of the currents carried by the power-lines inevitably produces some effects on the pipelines. Indeed the pipelines will experience an electromotive force that results in currents that can be harmful both in the short (high current densities during faults) and long (corrosion effects) terms. Moreover, these induced voltages may represent a danger for the personnel touching the structure. Due to the importance and complexity of these topics, scientific research on the subject is still conducted nowadays. The various techniques adopted for the task of computing the induced voltages and currents are generally based either on analytical calculations [1–3] or on the Finite Element Method (FEM) [4, 5]. Furthermore, some other recent works are based on hybrid techniques [6, 7], in which FEM is used to compute equivalent lumped parameters that can be used to obtain the induced voltages and currents. Whenever an analytical method is involved in the computations, the eventuality of the earth acting as a return circuit for the currents has to be taken into account. In [1, 2] Carson's formulae are chosen for accomplishing this task. These rely on the diffusion equation for assessing the time-dependent distribution of the currents in a semi-infinite homogeneous soil.

2. PROBLEM FORMULATION

In both methods presented in this work, the inductive coupling is the only mechanism taken into account while computing the induced voltages and currents. Basically, it is assumed that the electromagnetic interaction between the overhead power-line and the pipeline happens due to Faraday's law only. This means that the conductive and the capacitive coupling are not considered. The focus of this work is set on buried pipelines and indeed, thanks to the shielding effect of the soil towards the electric field, the capacitive coupling can be reasonably neglected. Moreover, with respect to conductive coupling, this is

Received 5 August 2017, Accepted 9 October 2017, Scheduled 21 October 2017

* Corresponding author: Andrea Cristofolini (andrea.cristofolini@unibo.it).

The authors are with the Department of Electrical, Electronic, and Information Engineering, University of Bologna, Italy.

of some relevance only if the pipeline is located in the vicinity of a faulted power-line with some degree of unbalance between the currents of the three phases, which would imply some kind of return current flowing through the soil surrounding the pipeline itself. Since this is a quite infrequent circumstance, it appears logical focusing on the sole inductive coupling, which is the only effect taking place in every possible situation.

2.1. Circuital Approach

The circuital approach considered in this paper for calculating the voltages induced on pipelines due to power lines is described in the Cigré standard [1] and consists of a few steps. Here the procedure in the case of a power line with three line conductors, indicated with the subscript $i = 1, \dots, 3$ and equipped with a single overhead ground wire (OGW), is shown (all quantities are given in SI metric system):

- (i) computation of the mutual impedance $\mathbf{Z}_{i\text{-OGW}}$ between each phase conductor and the OGW. Given the line currents \mathbf{I}_i , this allows finding the electromotive force induced on the OGW:

$$\mathbf{EMF}_{\text{OGW}} = \sum_{i=1}^3 \mathbf{Z}_{i\text{-OGW}} \mathbf{I}_i; \quad (1)$$

- (ii) calculation of \mathbf{Z}_{OGW} , the self-impedance of the OGW. Therefore, the current caused by the EMF on the OGW is $\mathbf{I}_{\text{OGW}} = \mathbf{EMF}_{\text{OGW}} / \mathbf{Z}_{\text{OGW}}$;
 (iii) once the value of \mathbf{I}_{OGW} is found, it can be treated as another line current, and the process described in the previous steps can be applied to the pipeline (indicated with the subscript p):

$$\mathbf{EMF}_p = \sum_{i=1}^3 \mathbf{Z}_{i-p} \mathbf{I}_i + \mathbf{Z}_{\text{OGW}-p} \mathbf{I}_{\text{OGW}}, \quad (2)$$

where \mathbf{Z}_{i-p} and $\mathbf{Z}_{\text{OGW}-p}$ are the mutual impedances between the pipeline and the i th conductor and the OGW, respectively.

This method relies upon the use of Carson's expressions [8] for the computation of the self- and mutual impedances of conductors in presence of a semi-infinite earth. That is, the calculated impedances are comprehensive of the earth, acting as the return path of the metallic conductors. Carson's results were expressed in terms of convergent infinite series, however (for the sake of convenience) some simplified expressions are normally used instead. The per-unit-length (p.u.l.) self-impedance \mathbf{Z}' of an above-soil conductor with earth return can be expressed as [9]:

$$\mathbf{Z}' = R' + \mu_0 \tan^{-1} \left(\frac{\beta}{\beta + 1} \right) + j\mu_0 f \left(\ln \frac{2\pi}{r} \right) + \ln \left(\sqrt{(1 + \beta)^2 + \beta^2} \right), \quad (3)$$

where R' is the p.u.l. resistance of the conductor, f the frequency, h the height of the conductor above the soil, $\beta = \frac{330}{h} \sqrt{\frac{\rho_{\text{soil}}}{2f}}$, and ρ_{soil} is the soil resistivity.

The calculation of the mutual impedance \mathbf{Z}_m between two earth return conductors is performed using the so-called polynomial form of Carson's series [2]

$$\mathbf{Z}_m = j2\pi f (F_1 + jF_2) \cdot 10^{-9}, \quad (4)$$

where, having defined $x = \alpha d$ and d being the distance between the two circuits and $\alpha = \sqrt{\frac{\omega\mu_0}{\rho_{\text{soil}}}}$, for $x \leq 10$

$$\begin{aligned} F_1 &= a_1 - a_2x + a_3x^2 - a_4x^3 + a_5x^4 - a_6x^5 + a_7e^{-x} - a_8\ln(x), \\ F_2 &= -b_1 + b_2x - b_3x^2 + b_4x^3 - b_5x^4 + b_6x^5 + b_7e^{-x} - b_8e^x - b_9\ln(x) \end{aligned} \quad (5)$$

whereas for $x > 10$

$$F_1 = 0 \quad F_2 = -\frac{400}{x^2} \quad (6)$$

with

$$\begin{aligned}
 a_1 &= 123.36; a_2 = 1.69; a_3 = 23.937; a_4 = 4.9614; \\
 a_5 &= 0.44212; a_6 = 0.01526; a_7 = 0.001215; a_8 = 200; \\
 b_1 &= 339; b_2 = 193.67; b_3 = 49.77; b_4 = 6.979; \\
 b_5 &= 0.5243; b_6 = 0.01672; b_7 = 180.42; b_8 = 0.00146; b_9 = 0.274.
 \end{aligned}
 \tag{7}$$

Finally, the p.u.l. self-impedance of the pipeline-earth circuit $\mathbf{Z}'_p = R'_p + j\omega L'_p$ can be computed with:

$$R'_p = \frac{\sqrt{\rho_p \mu_0 \mu_r \omega}}{\sqrt{2\pi D}} + \frac{\mu_0 \omega}{8} \quad \omega L'_p = \frac{\sqrt{\rho_p \mu_0 \mu_r \omega}}{\sqrt{2\pi D}} + \frac{\mu_0 \omega}{2\pi} \ln \left(\frac{3.7 \sqrt{\frac{\rho_{soil}}{\omega \mu_0}}}{D} \right),
 \tag{8}$$

where $\omega = 2\pi f$ is the angular frequency; ρ_p and μ_r are the resistivity and the relative magnetic permeability of the pipeline respectively; D is its external diameter.

Here are the fundamental hypotheses on which the aforementioned Carson's expressions are based:

- (i) **linearity of magnetic materials:** generally, pipelines are made of iron, which is a ferromagnetic material. For this reason, in the case of very high induced currents, the saturation of the magnetic medium could heavily influence the electromagnetic behaviour of the structure. However, a situation like this is likely to happen only in the case of extremely strong faults in the vicinity of the pipeline, a quite unusual circumstance;
- (ii) **weak coupling:** the circuital approach works on the assumption that the considered conductors are *weakly coupled* [10]. Therefore, the line conductors will induce currents in the pipeline, whereas the currents induced in the line conductors due to the currents that are induced in the pipeline are considered negligible;
- (iii) **constant network frequency (sinusoidal steady-state):** this allows using the phasor method. In this paper, all the results refer to a frequency of 50 Hz;
- (iv) **quasi-stationary approximation:** Carson's formulae for the self and mutual impedance of conductors with earth-return are based on the assumption of $J \gg \partial D / \partial t$. This is valid [10] if the condition $2\pi \frac{r_{p0-p}}{v} \ll \frac{1}{f}$ is verified. In this expression r_{p0-p} is the maximum linear extension of the physical domain and v represents the speed of propagation of the electromagnetic interaction in the given medium;
- (v) **homogeneous soil:** the electrical properties of the soil surrounding the pipeline are taken as constants.

An additional assumption on the proposed methodology is that the pipelines are parallel to the power lines. In particular, the calculations are performed with the aim of obtaining p.u.l. values. However, this method has a wider spectrum of applications than what is presented here. Indeed, the circuital method can be applied (with some inevitable degree of approximation) even to non-parallel configurations [1, 2, 9], subdividing the pipeline in several parallel equivalent configurations, and then solving a linear system. It is also possible to compute the shunt admittance to earth of the pipeline,

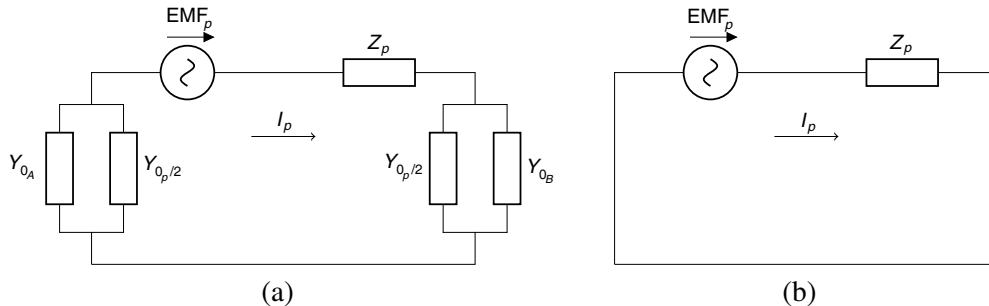

Figure 1. (a) Imperfect coating and earthing, (b) perfect coating and earthing.

which represents the imperfect coating of the pipeline itself. That would lead to writing a pi-equivalent circuit, depicted in Fig. 1(a), where the generator \mathbf{EMF}_p (representing the total induced EMF on considered axial portion of the pipeline) induces a current which finds its return path through the equivalent p.u.l. admittance $\mathbf{Y}'_p = \frac{\pi D}{\rho_c \delta_c} + j\omega \frac{\epsilon_0 \epsilon_r \pi D}{\delta_c}$. In the latter, ϵ_0 is the electric permittivity of the vacuum, ϵ_r the relative permittivity of the pipeline's coating, δ_c and ρ_c its thickness and resistivity respectively. However, for the purpose of a comparison with 2D FEM methodologies, a pipeline with perfect coating ($\mathbf{Y}'_p = 0$) is considered. In particular, the simulated pipeline is perfectly earthed at both ends ($\mathbf{Y}_{0_A} = \mathbf{Y}_{0_B} = 0$), thus leading to circuit (b) of Fig. 1.

2.2. Finite Element Formulation

A numerical procedure has been developed in order to analyse the effects of the AC interference induced by a transmission line on a buried pipeline. The method is based on a two dimensional finite element formulation for the solution of the problem in the quasi-magnetostatic assumption (i.e., $J \gg \partial D/\partial t$). The 2D formulation is obtained assuming that all the current densities flow in a perpendicular direction (which will hereafter referred to as z direction) with respect to the plane taken as calculation domain. Under this assumption, the magnetic flux density $\overline{\mathbf{B}}$ lies on the calculation plane and A_z is the only relevant component of the magnetic vector potential $\overline{\mathbf{A}}$. In this case, the current density along the z direction can be expressed as:

$$J_z = J_{z,0} - \sigma \frac{\partial A_z}{\partial t}, \quad (9)$$

and the governing equation for A_z can be written as follows [11]:

$$-\nabla \cdot \left(\frac{1}{\mu} \nabla A_z \right) = J_{z,0} - \sigma \frac{\partial A_z}{\partial t}. \quad (10)$$

This formulation does not require the aforementioned weak coupling approximation. Indeed, in this case the vector potential and its time derivative are a result of the current densities flowing on the whole domain. Thus, the current flowing through the overhead power lines are inherently affected by the pipeline and OGW currents. Assuming then a sinusoidal regime, a two dimensional complex formulation of (10) can be derived:

$$-\nabla \cdot \left(\frac{1}{\mu} \nabla \mathbf{A}_z \right) = \mathbf{J}_{0,z} - j\omega\sigma \mathbf{A}_z. \quad (11)$$

In Eq. (11), $\mathbf{J}_{0,z}$ represents the forcing term acting in the z direction and can be regarded as the current density that would travel through the conductors in a steady state regime.

Although the proposed formulation shares some of the assumptions underlying the Carson's formulae, like the linearity and isotropy of all the materials, FEM analysis allows a detailed analysis of cases where the complexity of the conductor location and the nonuniformity of the soil properties play an important role.

Equation (11) is discretized by means of a finite element method. Assuming that the considered domain Ω has been discretized in calculation mesh, the solution \mathbf{A}_z is approximated by a piecewise polynomial representation:

$$\tilde{\mathbf{A}}_z = \{N\}^T \{\mathbf{A}_z\}, \quad (12)$$

where $\{N\}$ is an array constituted by the shape functions for each node in the mesh, and $\{\mathbf{A}_z\}$ is constituted by the corresponding nodal values of the unknown. According to the Galerkin approach, the weak form of the weighted residual formulation can be written using the generic shape function N_k as weighting function:

$$\int_{\Omega} \nabla N_k \cdot \left(\frac{1}{\mu} \nabla \tilde{\mathbf{A}}_z \right) dS + j\omega \int_{\Omega} N_k \sigma \tilde{\mathbf{A}}_z dS = \int_{\Omega} N_k \mathbf{J}_{0,z} dS - \oint_{\partial\Omega} N_k \frac{1}{\mu} \frac{\partial \tilde{\mathbf{A}}_z}{\partial n} dl. \quad (13)$$

Inserting Eq. (12) in Eq. (13), a linear system is finally obtained:

$$[\mathbf{M}]\{\mathbf{A}_z\} = \{\mathbf{f}\} \quad (14)$$

which, once solved, allows one to determine the value of the unknown $\{\mathbf{A}_z\}$. The left- and right-hand side terms in Eq. (14) (that is, the complex coefficient matrix $[\mathbf{M}]$ multiplied by $\{\mathbf{A}_z\}$ and the array $\{\mathbf{f}\}$) are derived from the left- and right-hand side terms in Eq. (13), respectively. Particularly, the right-hand side term $\{\mathbf{f}\}$ depends on the distribution of the applied current density $\mathbf{J}_{0,z}$ over the calculation domain and on the conditions applied to the domain boundary $\partial\Omega$. The current densities can then be evaluated over the calculation domain using Eq. (9), that in phasorial form reads:

$$\mathbf{J}_z = \mathbf{J}_{0,z} - j\omega\mathbf{A}_z. \tag{15}$$

The numerical integration of this equation, performed using the Gaussian quadrature formulae, yields the currents flowing (along the z direction) in the regions of the domain. We can therefore define:

$$\mathbf{I}_{\text{soil}}(\mathbf{J}_{0,z}) = \int_{\text{soil}} \mathbf{J}_z dS, \tag{16a}$$

$$\mathbf{I}_p(\mathbf{J}_{0,z}) = \int_{\text{pipe}} \mathbf{J}_z dS, \tag{16b}$$

$$\mathbf{I}_{\text{OGW}}(\mathbf{J}_{0,z}) = \int_{\text{OGW}} \mathbf{J}_z dS \tag{16c}$$

as the electric current flowing through the soil, the pipeline and the OGW(s), respectively. In the definitions of Eq. (16), it is highlighted that the currents are functions of the applied current density $\mathbf{J}_{0,z}$ since, as previously noted, the solution \mathbf{A}_z depends on $\mathbf{J}_{0,z}$. For instance, if the applied $\mathbf{J}_{0,z}$ is set to 0 on every conductor except for the power line phase conductors, the condition schematically represented in Fig. 2(a) is obtained. As mentioned in the previous section, the results obtained by means of the FEM approach will be compared to the calculations based on the Carson's formulae. For this purpose, we refer to the case depicted in Fig. 1(b), where a perfectly coated ($\mathbf{Y}'_p = 0$) and perfectly earthed at both ends ($\mathbf{Y}_{0A} = \mathbf{Y}_{0B} = 0$) pipeline is considered. We also assume that the OGW is perfectly earthed at both ends. The applied current density $\mathbf{J}_{0,z}$ on each conductor is assumed to be produced by a forcing electric field $\mathbf{E}_{0,z}$ applied on the z direction:

$$\mathbf{J}_{0,z} = \sigma\mathbf{E}_{0,z}. \tag{17}$$

Since the pipeline and OGW are perfectly earthed, the forcing electric field $\mathbf{E}_{0,z}$ is the same through the soil, pipeline and OGW. As a result, the currents in Eq. (16) depend on a unique forcing field $\mathbf{E}_{0,z}$ through Eq. (17). Referring to Fig. 2(b), we now want to find the conditions under which the sum of the currents defined in Eq. (16) is equal to zero, in order to reproduce the real physical behaviour of the considered system. That is, we want to find the field $\mathbf{E}_{0,z}$ that verifies the condition:

$$\mathbf{S}(\mathbf{E}_{0,z}) = \mathbf{I}_{\text{soil}}(\mathbf{E}_{0,z}) + \mathbf{I}_p(\mathbf{E}_{0,z}) + \mathbf{I}_{\text{OGW}}(\mathbf{E}_{0,z}) = 0. \tag{18}$$

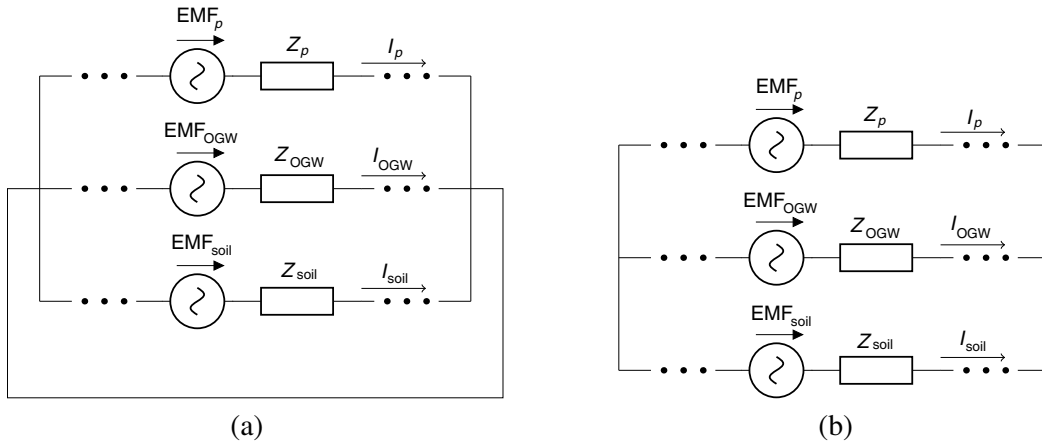

Figure 2. (a) Imperfect coating and earthing, (b) perfect coating and earthing.

Given the linearity of the problem, the function $\mathbf{S} = \text{Re}[\mathbf{S}] + j\text{Im}[\mathbf{S}]$ is a linear function of the field $\mathbf{E}_{0,z} = \text{Re}[\mathbf{E}_{0,z}] + j\text{Im}[\mathbf{E}_{0,z}]$ and can be conveniently expanded in a Taylor first degree polynomial centred on a generic $\mathbf{E}_{0,z}^*$:

$$\begin{Bmatrix} \text{Re}[\mathbf{S}(\mathbf{E}_{0,z})] \\ \text{Im}[\mathbf{S}(\mathbf{E}_{0,z})] \end{Bmatrix} = \begin{Bmatrix} \text{Re}[\mathbf{S}(\mathbf{E}_{0,z}^*)] \\ \text{Im}[\mathbf{S}(\mathbf{E}_{0,z}^*)] \end{Bmatrix} + [\mathbf{B}] \begin{Bmatrix} \text{Re}[\mathbf{E}_{0,z}] - \text{Re}[\mathbf{E}_{0,z}^*] \\ \text{Im}[\mathbf{E}_{0,z}] - \text{Im}[\mathbf{E}_{0,z}^*] \end{Bmatrix}, \quad (19)$$

where $[\mathbf{B}]$ the Jacobian matrix:

$$[\mathbf{B}] = \begin{bmatrix} \frac{\partial \text{Re}[\mathbf{S}]}{\partial \text{Re}[\mathbf{E}_{0,z}]} & \frac{\partial \text{Re}[\mathbf{S}]}{\partial \text{Im}[\mathbf{E}_{0,z}]} \\ \frac{\partial \text{Im}[\mathbf{S}]}{\partial \text{Re}[\mathbf{E}_{0,z}]} & \frac{\partial \text{Im}[\mathbf{S}]}{\partial \text{Im}[\mathbf{E}_{0,z}]} \end{bmatrix}. \quad (20)$$

Expression (19) is used to find the field $\mathbf{E}'_{0,z}$ satisfying Eq. (18). Indeed, given an initial guess $\mathbf{E}_{0,z}^*$, the field $\mathbf{E}'_{0,z}$ can be found by equating the expansion in Eq. (19) to zero:

$$\begin{Bmatrix} \text{Re}[\mathbf{E}'_{0,z}] \\ \text{Im}[\mathbf{E}'_{0,z}] \end{Bmatrix} = \begin{Bmatrix} \text{Re}[\mathbf{E}_{0,z}^*] \\ \text{Im}[\mathbf{E}_{0,z}^*] \end{Bmatrix} - [\mathbf{B}]^{-1} \begin{Bmatrix} \text{Re}[\mathbf{S}(\mathbf{E}_{0,z}^*)] \\ \text{Im}[\mathbf{S}(\mathbf{E}_{0,z}^*)] \end{Bmatrix}. \quad (21)$$

Hence, the procedure to solve the problem is articulated as follows:

- (i) a first guess $\mathbf{E}_{0,z}^*$ is chosen, and the forcing current density $\mathbf{J}_{0,z}$ is found using Eq. (17) over the calculation domain. The system in Eq. (14) is then solved, and the quantity $\mathbf{S}(\mathbf{E}_{0,z}^*)$ can be evaluated through Eqs. (16) and (18);
- (ii) the elements in the Jacobian matrix are numerically computed by perturbing in turn the real and imaginary parts of the initial guess $\mathbf{E}_{0,z}^*$ with a small quantity and finding the corresponding variation of \mathbf{S} through the method described in the previous step;
- (iii) the field $\mathbf{E}'_{0,z}$ is found using Eq. (21).

3. RESULTS AND DISCUSSION

In order to perform a comparison between the circuitual and 2D FEM approaches, the current on the pipeline was computed for various different physical configurations using the two corresponding proposed methods. Those configurations consisted of three main cases, which correspond to three different positions of the pipeline. In the first one (A) the pipeline is located under the center of the power line, buried in the soil at a depth of 2 m. Then, the other two configurations (B) and (C) were obtained positioning the pipeline at 8 m and 18 m respectively from the center of the power line, without changing its depth. For each of the three pipeline positions, three simulations were performed, as depicted in Fig. 3:

- (i) three phase system, single circuit without OGW;
- (ii) three phase system, single circuit with OGW; $h_{\text{OGW}} = 12.185$ m
- (iii) three phase system, single circuit with OGW. $h_{\text{OGW}} = 15.185$ m

The three configurations considered and the coordinates of the conductors are shown in Fig. 3. The electrical conductivity σ of the line conductors and OGW has been set equal to $5.9 \cdot 10^7$ S/m, whereas for the pipeline and soil $\sigma_p = 5 \cdot 10^6$ S/m and $\sigma_{\text{soil}} = 2 \cdot 10^{-2}$ S/m are chosen. The radii of the line conductors and OGW have been set respectively equal to 20 mm and 16 mm. The pipeline has been modeled as a hollow ferromagnetic ($\mu_r = 1800$) conductor, with an external radius of 25 cm and a thickness of 2 cm.

Concerning the FEM code, as stated in Section 2.2 the physical domain has to be discretized. For this purpose, a 78791 nodes, 157420 triangles mesh was used. The mesh boundary consists of a circumference of radius 600 m, upon which the normal component of the magnetic flux density is set to zero by enforcing the boundary condition $A_z = 0$. For the regions corresponding to the air and the soil surrounding the power line and the pipeline respectively, a non-structured mesh was employed.

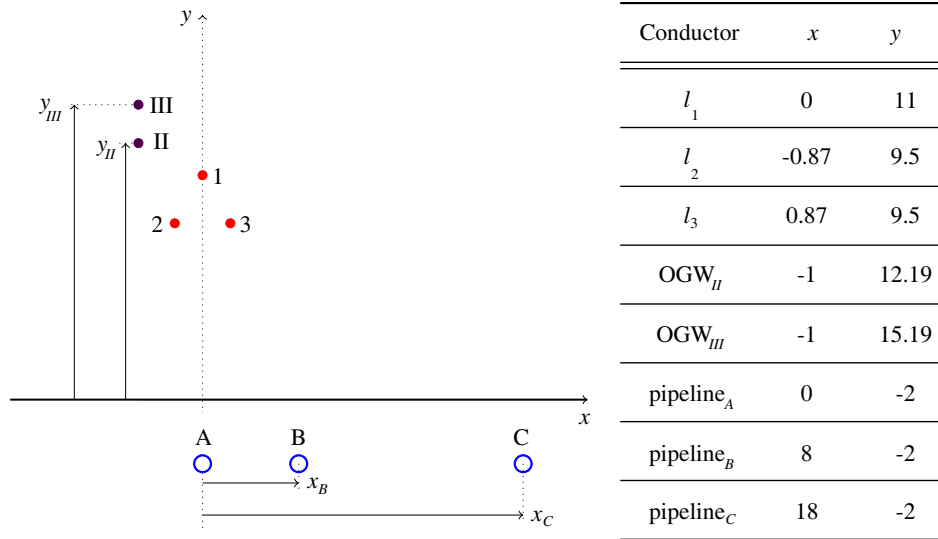

Figure 3. Scheme of the pipeline and OGW positioning considered for the calculation.

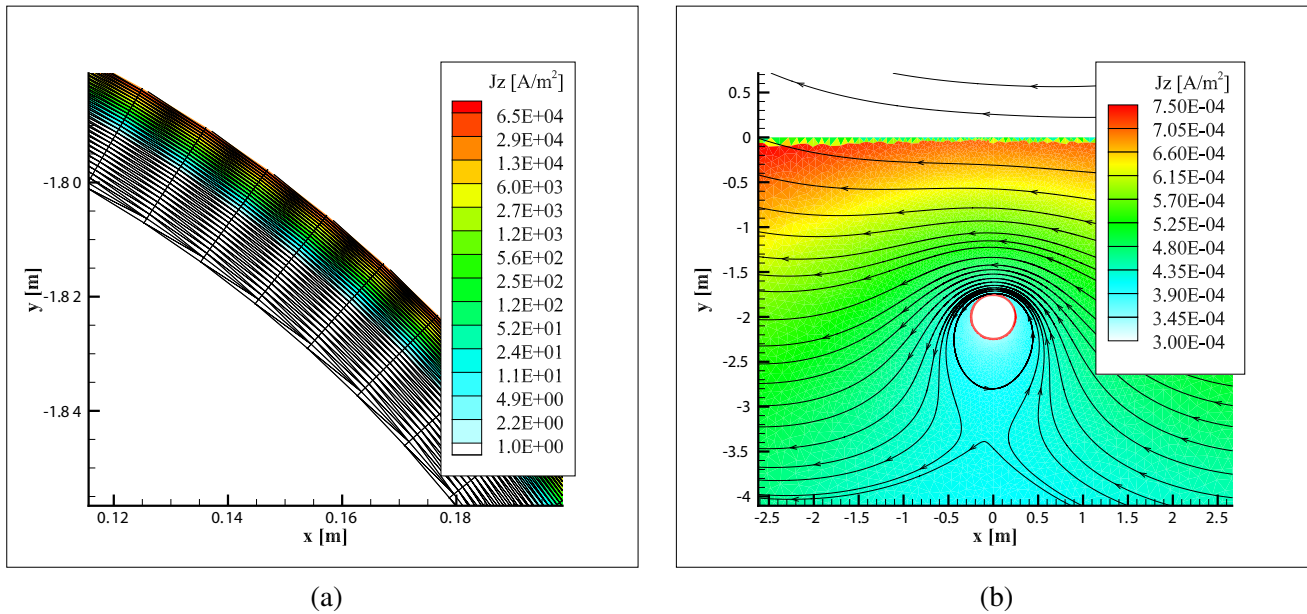

Figure 4. Distribution of $|\mathbf{J}_z|$ through (a) the pipeline and (b) the soil.

Aiming to increase the accuracy on the regions subjected to the skin effect, the external part of the metallic conductors has been represented instead with a structured mesh. As an example, Fig. 4(a) shows the current density distribution on the pipeline cross section. As can be noticed, in order to ensure a good level of confidence in the results, the pipeline was meshed using 30 divisions in the radial direction. In Fig. 4(b) the distribution of the currents flowing through the soil surrounding the pipeline is depicted. It is also interesting to note how the distribution of the magnetic field lines surrounding the pipeline is modified by \mathbf{I}_p . The various FEM simulations were run imposing for the line conductors $\mathbf{J}_{0-1} = 1 \cdot 10^8 = \underline{0^\circ}A$, $\mathbf{J}_{0-2} = 1 \cdot 10^8 / \underline{-120^\circ}A$ and $\mathbf{J}_{0-3} = 1 \cdot 10^8 / \underline{120^\circ}A$ respectively, which corresponds through Eq. (17) to a three-phase balanced system of voltages. Unlike the circuital method, in the 2D FEM approach the absence of the *weak coupling* hypothesis causes every line current to be affected by the other conductor's currents. Therefore, for each different physical configuration, the line currents

Table 1. Case A — $x_p = 0$ m.

Current [A]	I — no OGW	II — OGW 12.185 m	III — OGW 15.185 m
I_1	5801.94/ <u>-86.44°</u>	5943.14/ <u>-86.34°</u>	5847.74/ <u>-86.39°</u>
I_2	5804.05/ <u>153.5°</u>	5727.63/ <u>154.2°</u>	5784.68/ <u>153.7°</u>
I_3	5805.32/ <u>33.60°</u>	5761.65/ <u>32.90°</u>	5795.76/ <u>33.34°</u>
$I_{OGW_{Car}}$	-	527.175/ <u>89.42°</u>	206.944/ <u>93.45°</u>
$I_{OGW_{FEM}}$	-	583.104/ <u>91.42°</u>	248.784/ <u>94.77°</u>
$I_{p_{Car}}$	67.0717/ <u>-70.03°</u>	131.823/ <u>-86.68°</u>	97.8112/ <u>-76.99°</u>
$I_{p_{FEM}}$	79.2456/ <u>-53.68°</u>	140.307/ <u>-93.68°</u>	103.238/ <u>-76.39°</u>

Table 2. Case B — $x_p = 8$ m.

Current [A]	I — no OGW	II — OGW 12.185 m	III — OGW 15.185 m
I_1	5774.91/ <u>-86.44°</u>	5943.59/ <u>-86.30°</u>	5848.09/ <u>-86.35°</u>
I_2	5783.11/ <u>153.4°</u>	5721.97/ <u>154.3°</u>	5779.05/ <u>153.7°</u>
I_3	5791.09/ <u>33.60°</u>	5765.53/ <u>32.85°</u>	5800.12/ <u>-33.30°</u>
$I_{OGW_{Car}}$	-	530.321/ <u>90.20°</u>	209.092/ <u>95.24°</u>
$I_{OGW_{FEM}}$	-	572.824/ <u>90.85°</u>	240.286/ <u>93.36°</u>
$I_{p_{Car}}$	65.1739/ <u>-103.7°</u>	126.913/ <u>-104.3°</u>	91.0675/ <u>-101.0°</u>
$I_{p_{FEM}}$	65.4451/ <u>-77.18°</u>	143.465/ <u>-110.9°</u>	100.001/ <u>-101.3°</u>

Table 3. Case C — $x_p = 18$ m.

Current [A]	I — no OGW	II — OGW 12.185 m	III — OGW 15.185 m
I_1	5807.51/ <u>-86.39°</u>	5948.06/ <u>-86.32°</u>	5851.71/ <u>-86.35°</u>
I_2	5794.57/ <u>153.5°</u>	5720.95/ <u>154.3°</u>	5776.52/ <u>153.7°</u>
I_3	5808.25/ <u>33.51°</u>	5759.24/ <u>32.80°</u>	5797.46/ <u>33.26°</u>
$I_{OGW_{Car}}$	-	540.438/ <u>89.86°</u>	215.530/ <u>95.17°</u>
$I_{OGW_{FEM}}$	-	562.485/ <u>91.37°</u>	232.824/ <u>94.30°</u>
$I_{p_{Car}}$	41.2048/ <u>-134.0°</u>	99.1569/ <u>-112.5°</u>	67.1861/ <u>-112.5°</u>
$I_{p_{FEM}}$	39.5672/ <u>-102.4°</u>	122.538/ <u>-122.6°</u>	75.6333/ <u>-115.3°</u>

computed with the 2D FEM have been used as the imposed line currents of the circuital method in order to have the same starting line currents in the two codes. In Tables 1, 2 and 3, the results for the three previously described positions of the pipeline are shown.

As can be observed, the current induced on the pipeline increases when the OGW is present. This effect has also been reported in [1]. This is because in the three-phase overhead line, the magnetic field generated by a current tends to be cancelled by the other two phases. Thus, the field produced by the power lines decreases more rapidly than the one generated by the OGW. For this reason, even if the current carried by the OGW is smaller than the currents flowing through the overhead power line, it is capable of producing significant effects on the pipeline.

According to these results, the agreement between the two approaches is consistent. In particular, some very close results can be noticed for the (B) and (C) cases, i.e., when the pipeline is not located directly under the power line.

It is also worth highlighting that once an OGW is included in the configuration, the difference between the two approaches increases. However, the described discrepancy becomes narrower when the OGW is moved farther from the other conductors. This fact shows that the computation of the currents on the OGW is somehow a critical task in this context (position **III**).

For this reason, some interesting conclusions can be drawn by looking at the computed currents on the pipeline (using the circuital method) if \mathbf{I}_{OGW} is forced on the value computed using the 2D FEM approach. Actually, running the circuital code with imposed OGW currents is not a critical choice, as it just corresponds to a situation where those currents are being measured, and thus used as an input value for the codes.

The following three tables summarize the results. The input line current values used to obtain the results reported in Table 4, Table 5 and Table 6 are the ones that can be found in columns corresponding to **II** and **III** of Table 1, Table 2 and Table 3, respectively. As can be seen, when using the circuital method with imposed OGW current, the computed pipeline current is higher and closer to the FEM result, than that obtained by utilising the Carson's formulae for evaluating the OGW current. This may point out that the weak interaction assumption underlying the Carson's formulae does not allow, in this case, a correct estimate of the current flowing through the OGW.

Table 4. Case D — $x_p = 0$ m, $\mathbf{I}_{\text{OGW}} = \mathbf{I}_{\text{OGW}_{\text{FEM}}}$.

Current [A]	II — OGW 12.185 m	III — OGW 15.185 m
I_{OGW}	583.104/91.42°	248.784/94.77°
$I_{p_{\text{Car}}}$	151.198/−83.71°	111.895/−76.44°
$I_{p_{\text{FEM}}}$	140.307/−93.68°	103.238/−76.39°

Table 5. Case E — $x_p = 8$ m, $\mathbf{I}_{\text{OGW}} = \mathbf{I}_{\text{OGW}_{\text{FEM}}}$.

Current [A]	II — OGW 12.185 m	III — OGW 15.185 m
I_{OGW}	572.824/90.85°	240.286/93.36°
$I_{p_{\text{Car}}}$	139.715/−101.4°	101.381/−100.2°
$I_{p_{\text{FEM}}}$	143.465/−110.9°	100.001/−101.3°

Table 6. Case F — $x_p = 18$ m, $\mathbf{I}_{\text{OGW}} = \mathbf{I}_{\text{OGW}_{\text{FEM}}}$.

Current [A]	II — OGW 12.185 m	III — OGW 15.185 m
I_{OGW}	562.485/91.37°	232.824/94.30°
$I_{p_{\text{Car}}}$	103.271/−108.6°	72.1512/−111.0°
$I_{p_{\text{FEM}}}$	122.538/−122.6°	75.6333/−115.3°

4. CONCLUSIONS

In this work, several configurations of a buried metallic pipeline located close to an overhead power line are analysed, using both a circuital and a 2D FEM-based approaches. The latter was embedded with a procedure dedicated to reproducing the same physical conditions assumed by Carson. The currents flowing through the pipeline and the possible OGW are indeed forced to take the meshed soil as a return path. This is consistent with Carson's approach, based on computing the impedances of earth-return conductors. The results obtained using the two methods are in good agreement, especially

when dealing with very simple configurations. Whenever an OGW is added, or some more critical positions of the pipeline with respect to the overhead power line are considered, the differences of the two approaches increase, though not excessively. Overall, this work shows that the proposed methodology for enforcing the return of the currents through the soil in a 2D FEM code performs consistently with the Carson-based approach. However, as the FEM approach does not require some of the simplifying hypotheses adopted by Carson, its applicability is broader. Therefore, its use can be extended for physical configurations involving higher complexity without the computational burden presented by a 3D code.

REFERENCES

1. Cigré, *Guide on the Influence of High Voltage AC Power Systems on Metallic Pipelines*, Working Group 36.02, 1995.
2. Directive, C. C. I. T. T., *Vol. III — Calculating Induced Voltages and Currents in Practical Cases*, 1989.
3. Campione, S., L. K. Warne, L. I. Basilio, C. D. Turner, K. L. Cartwright, and K. C. Chen, “Electromagnetic pulse excitation of finite-and infinitely-long lossy conductors over a lossy ground plane,” *Journal of Electromagnetic Waves and Applications*, Vol. 31, No. 2, 209–224, 2017.
4. Micu, D. D., G. C. Christoforidis, and L. Czumbil, “AC interference on pipelines due to double circuit power lines: A detailed study,” *Electric Power Systems Research*, Vol. 103, 1–8, 2013.
5. Popoli, A., A. Cristofolini, L. Sandrolini, B. T. Abe, and A. Jimoh, “Assessment of AC interference caused by transmission lines on buried metallic pipelines using FEM,” *International Applied Computational Electromagnetics Society Symposium (ACES)*, Florence, Italy, 2017.
6. Christoforidis, G. C., D. P. Labridis, and P. S. Dokopoulos, “A hybrid method for calculating the inductive interference caused by faulted power lines to nearby buried pipelines,” *IEEE Transactions on Power Delivery*, Vol. 20, No. 2, 1465–1473, 2005.
7. Christoforidis, G. C., D. P. Labridis, and P. S. Dokopoulos, “Inductive interference on pipelines buried in multilayer soil due to magnetic fields from nearby faulted power lines,” *IEEE Transactions on Electromagnetic Compatibility*, Vol. 47, No. 2, 254–262, 2005.
8. Carson, J. R., “Wave propagation in overhead wires with ground return,” *Bell Labs Technical Journal*, Vol. 5, No. 4, 539–554, 1926.
9. Tleis, N., *Power Systems Modelling and Fault Analysis: Theory and Practice*, Newnes, 2007.
10. Paul, C. R., *Introduction to Electromagnetic Compatibility*, John Wiley & Sons, 2006.
11. Steele, C. W., *Numerical Computation of Electric and Magnetic Fields*, 2nd edition, Chapman & Hall, New York, 1997.