

Mutual Coupling Reduction between Closely Placed Microstrip Patch Antenna Using Meander Line Resonator

Jeet Ghosh^{1,*}, Sandip Ghosal², Debasis Mitra¹, and Sekhar Ranjan Bhadra Chaudhuri¹

Abstract—An approach of reducing Mutual Coupling between two patch antennas is proposed in this paper. Here, a meander line resonator is placed in between the radiating elements. By inserting the meander line resonator between the patch antennas with the edge-to-edge distance less than $\lambda/18$, about 8 dB reduction of Mutual Coupling throughout the 10-dB bandwidth has been achieved without degrading the radiation pattern. The circuit model of the proposed configuration is carried out in this paper. The envelope correlation coefficient investigation has been done and the results are presented. The proposed structure has been fabricated and measured.

1. INTRODUCTION

Mutual Coupling is an inevitable phenomenon for multiple antenna system. This property degrades the system performance in two ways, namely by increasing coupling and by distorting the radiation pattern. It is well-known that coupling between two patches, two apertures, or two wires is a function of position of one element relative to other [1]. The aforesaid problem will be increased if the antennas are very close to each other.

Reduction of Mutual Coupling is one of the most appealing domains for antenna designers since early days. Generally, Mutual Coupling analysis is made by two ways; transmission line model [2] and cavity model [3, 4]. Recently some of the methodologies [5–19] were used for the reduction of Mutual Coupling by using some structures like Electromagnetic Band Gap (EBG) structure [5–8], Defective Ground Structure (DGS) [9], different shape resonator [10–12] etc. In [13], a slot was designed on the ground plane to decrease Mutual Coupling between radiating elements. The configuration used in [13] is a simple structure, but it affected the radiation pattern mainly on the rear side. Degradation in radiation pattern could be overcome by mushroom type EBG structure [5, 6]. However, these structures involved plated through hole (vias) which generates an electric loss and also the structures are very complicated from manufacturing perspective. For eliminating the need of vias, a novel uni-planar compact EBG (UC-EBG) structure was proposed in [7, 8]. Main disadvantages of the UC-EBG structure are its design complexity. It is noted that to reduce mutual coupling a multilayer structure has been proposed in [17].

Some other techniques were reported by using slotted complementary split ring resonator (SCSRR) [14] and slot combined complementary split ring resonator (SCCSSR) [15] structure to reduce the Mutual Coupling between the radiating elements. It is noted in [15] that the gain of the antenna was reduced and the side lobe level was enhanced with respect to the reference antenna. Waveguide Metamaterial (WG-MTM) is also an effective choice to increase isolation between two radiating elements [17–19]. In [17, 18] magnetic resonance property as well as band gap property of WG-MTM were used to reduce coupling between two H plane couple patch antenna. Epsilon negative

Received 22 January 2016, Accepted 21 March 2016, Scheduled 13 April 2016

* Corresponding author: Jeet Ghosh (jeet.ghosh07@gmail.com).

¹ Department of Electronics and Telecommunication Engineering, Indian institute of Engineering Science and Technology Shibpur, India. ² Department of Electronics & Electrical Communication Engineering, Indian Institute of Technology Kharagpur, India.

(ENG) and Mu negative (MNG) WG-MTM structure were used in [19] to reduce surface wave coupling between E plane and H plane couple patch antenna respectively. Different resonating structure was placed between the radiating elements to decrease Mutual Coupling [10–12]. The main challenge of the resonator design is to control cross polar power that may increase due to horizontal arms in the resonator structure [10].

In this paper, a meander line resonator is inserted between the radiating elements for better isolation with minimum level of cross polar power. It is found that a significant increased isolation can be obtained between a pair of microstrip antennas with edge to edge distance of $\lambda/18$ between two elements. The coupling suppression of 8–10 dB is obtained throughout the 10 dB impedance bandwidth. The circuit model of the proposed configuration is developed and circuit parameter values are extracted in this paper. The proposed design can be employed for reducing Mutual Coupling value of closely placed patch antenna effectively.

2. ANTENNA STRUCTURE

The setup model used to demonstrate the Mutual Coupling reduction is shown in Figure 1(a), where two identical microstrip antennas having resonant frequency of 2.8 GHz fabricated on Fr4 Epoxy ($\epsilon_r = 4.4$, Thickness = 1.59 mm, Dielectric Loss Tangent = 0.02) substrate. The length (L) and the width (W) of the reference antenna are 24.8 mm and 24.6 mm respectively. Edge to edge distance between the two patch antennas (g) is 6 mm.

Two patches are coupled through all present media, i.e., substrate and air, when they are placed closed to each other. The coupling through substrate layer is done by the surface wave, and the coupling through the air medium is the direct patch-to-patch near field coupling [10]. One of the two couplings may become dominant depending on its topology and geometry of the structure.

The direct Mutual Coupling between two patch elements can be controlled by adding an extra indirect coupling path. The main aim of this work is to create a suitable extra coupling path that opposes the signal going directly from one radiating element to other. An extra requirement is the decoupling unit should not degrade the radiation pattern.

In this design meander line resonator act as a decoupling unit which is shown in Figure 1(b). Meander line resonator has four long arms with an opposite current flow as shown in Figure 2. For this phenomenon their contribution to the far field to be cancelled by each other, preventing destructive effects on the radiation properties of the elements.

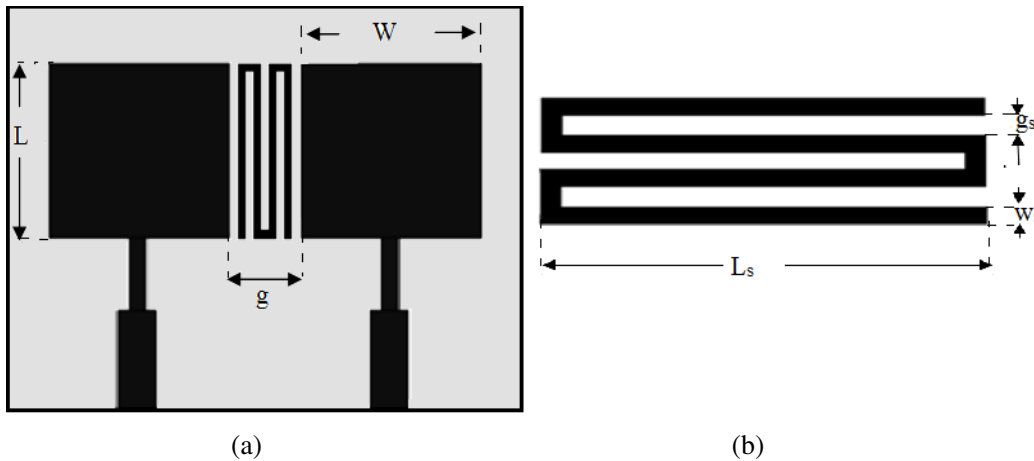

Figure 1. (a) Antenna structure with decoupling unit. (b) Decoupling unit (Meander line resonator).

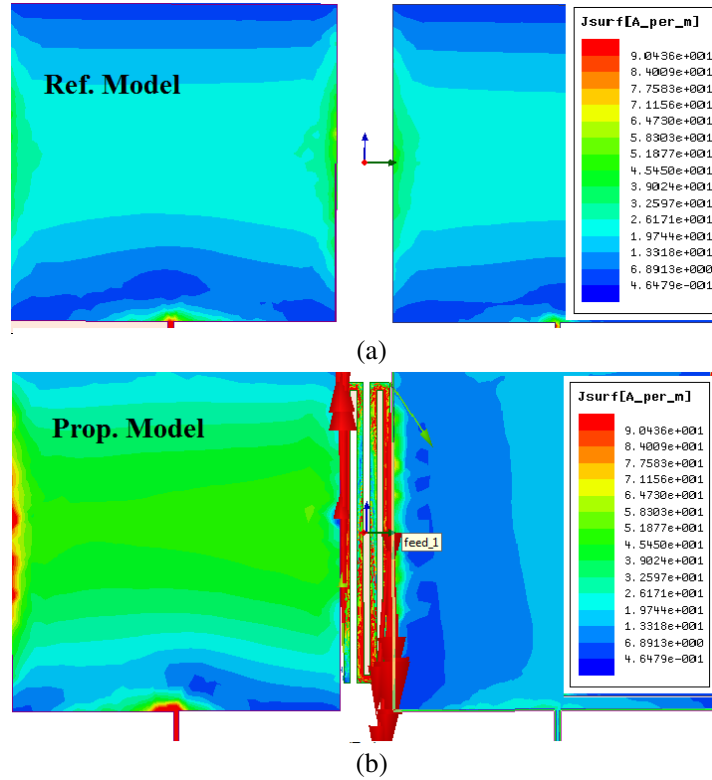

Figure 2. Surface current distributions. (a) Reference model and (b) proposed model.

3. RESULT

The two patch antennas are placed 6 mm (edge to edge) apart from each other. A meander line resonator is sandwiched between them to reduce Mutual Coupling between the radiating elements. To investigate the proposed antenna design shown in Figure 1, high frequency structure simulation (HFSS) software [21] are used for simulation and optimization. Figure 3 exhibits S_{21} variation for different length (L_s) of meander line resonator. It is found that the optimum length (L_s), width (W_s) and gap (g_s) of the meander line are 21 mm, 0.5 mm and 0.5 mm respectively. S parameters of the antenna structure are presented in Figure 4. S_{21} of the antenna without meander line resonator is about -10 dB in the operating region. However, there is a non-zero coupling between two radiating element or antenna port indicated by the S_{21} curve mainly in the operating region. By inserting the proposed decoupling element, S_{21} is decreased around -20 dB in the operating band of the antenna. It can be seen that the improvement is achieved over the full operating range of the antenna system.

In order to provide a deep understanding of the overall configuration the conceptual equivalent circuit model is shown in Figure 5. The equivalent circuit is a network realized by cascading three circuit sections together. In the equivalent circuit representation the patch antenna can be modelled by a resonant circuit with inductance L_P and capacitance C_P which is marked as Section 1 whereas the equivalent circuit of the decoupling unit, that is the meander line resonator is marked as Section 2 in Figure 5. It might be noted in Section 2 that, the inductance L_{ML} and the capacitance C_{ML} mainly model the effect of the meander line section and depends upon the length (L_s) and gap (g_s) between the two consecutive horizontal arms. The losses such as ohmic and dielectric loss associated with the meander line resonator are modelled by R_{ML} in the circuit. It is well-known that, the resonance frequency (f_r) of such decoupling unit is dependent on the value of inductance (L_{ML}) and capacitance (C_{ML}). In order to provide further mathematical explanation the value of L_{ML} and C_{ML} can be

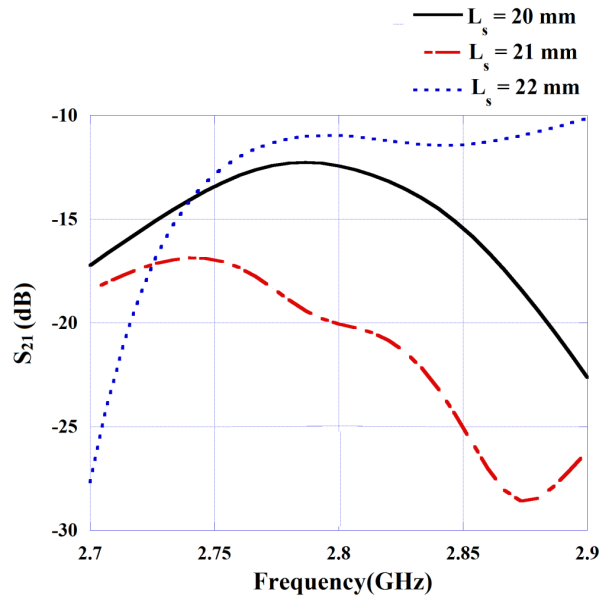

Figure 3. S_{21} for different values of L_s .

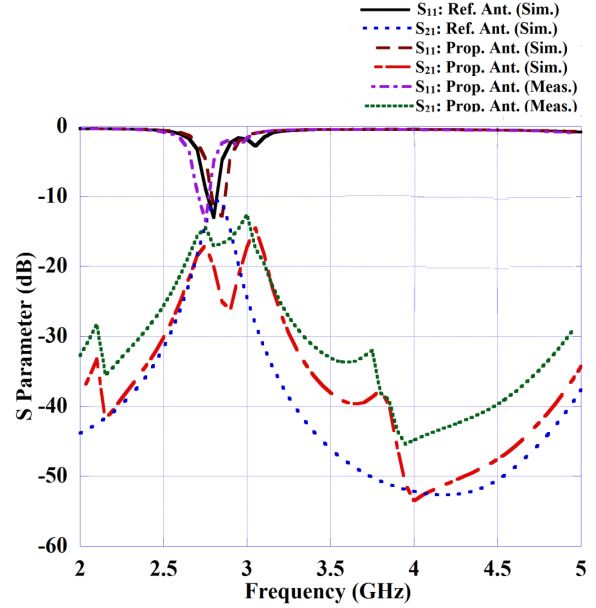

Figure 4. S parameters (S_{11} & S_{21}) of the antenna elements.

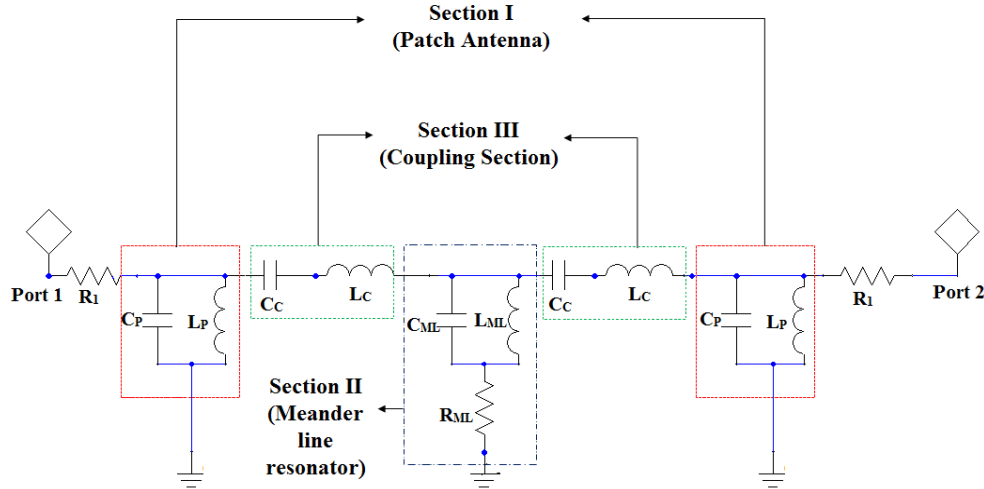

Figure 5. Equivalent circuit diagram of the proposed model.

computed by the help of Equation (1).

$$f_r = \frac{1}{2\pi\sqrt{L_{ML}C_{ML}}} \quad (1)$$

It might be noted that the coupling between patch and meander line resonator is a combination of inductive (L_C) and capacitive (C_C) coupling as shown in Section 3 of Figure 5. The former one is more dominated because the meander line is coupled via non radiating edge of the patch antenna. The circuit parameters of the equivalent circuit model have been extracted by the help of optimizing and tuning feature of Ansoft designer [22]. The parameter of equivalent lumped circuit model is extracted and tabulated in Table 1. Figure 6 of shows the full wave EM simulated and circuit simulated S_{21} of the proposed and reference antenna. Reasonable consistency is observed in the frequency region of interest

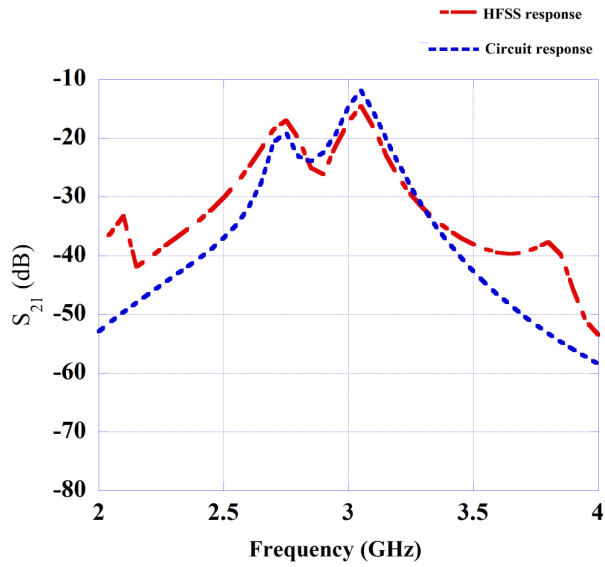

Figure 6. S_{21} comparison with full wave simulation (HFSS) and circuit simulation.

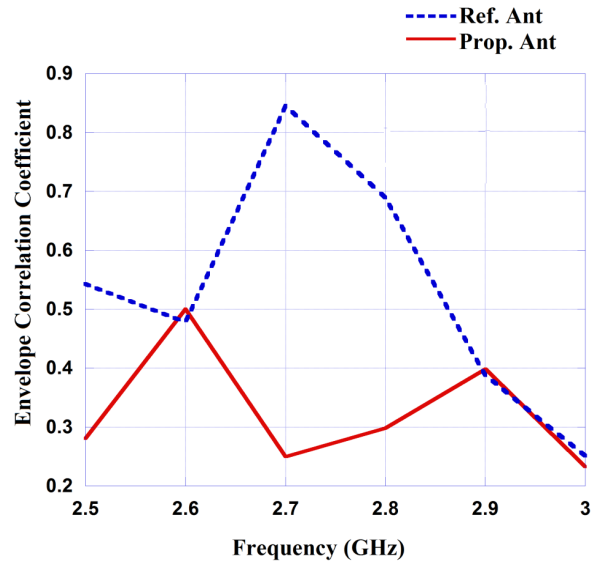

Figure 7. Correlation coefficient of the antenna elements.

Table 1. Optimize value of the equivalent circuit model of the proposed structure.

R_1	C_P	L_P	C_{ML}	L_{ML}	R_{ML}	C_C	L_C
104.442	0.75 pF	6.325 nH	4.0586 pF	0.806 nH	114.564	0.021 pF	134.592 nH

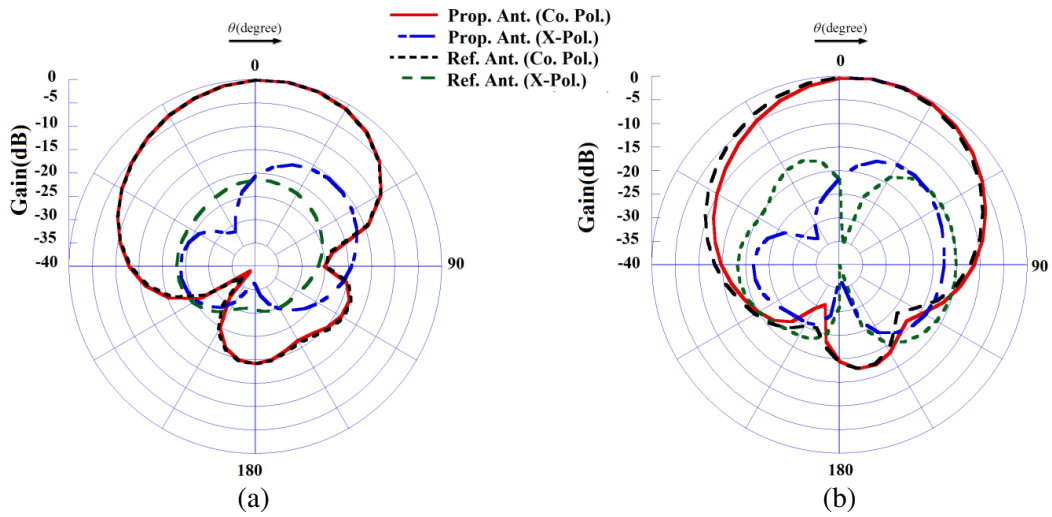

Figure 8. Radiation pattern of proposed and reference antenna. (a) E plane. (b) H plane.

between the circuit and full wave EM simulated results.

Another important parameter for the isolation is envelope correlation coefficient. The diversity capability of a system can be evaluated using the envelope correlation coefficient. According to [20] the

envelope correlation coefficient between two elements can be calculated by the Equation (2).

$$\rho_{12} = \left| \frac{\iint (XPR \cdot E_{\theta_1}(\Omega)E_{\theta_2}^*(\Omega)P_{\theta} + E_{\phi_1}(\Omega)E_{\phi_2}^*(\Omega)P_{\phi}) d\Omega}{\sqrt{\iint (XPR \cdot G_{\theta_1}(\Omega)P_{\theta} + G_{\phi_1}(\Omega)P_{\phi}) d\Omega \iint (XPR \cdot G_{\theta_2}(\Omega)P_{\theta} + G_{\phi_2}(\Omega)P_{\phi}) d\Omega}} \right|^2 \quad (2)$$

where Ω is the solid angle, $G_{\theta_1} = E_{\theta_1}(\Omega)E_{\theta_1}^*(\Omega)$, $G_{\theta_2} = E_{\theta_2}(\Omega)E_{\theta_2}^*(\Omega)$, and $E_{\theta_1}(\Omega)$, $E_{\theta_2}(\Omega)$ being the θ (vertical) polarised complex radiation patterns of antennas 1 and the antennas 2 of the system, and $E_{\phi_1}(\Omega)$, $E_{\phi_2}(\Omega)$ being the ϕ (horizontal) polarized complex radiation patterns of antenna 1 and the antenna 2 of the system; XPR is the cross polar discrimination is defined as time averaged vertical to horizontal power ratio. The θ and ϕ component of the angular density function of the incoming wave

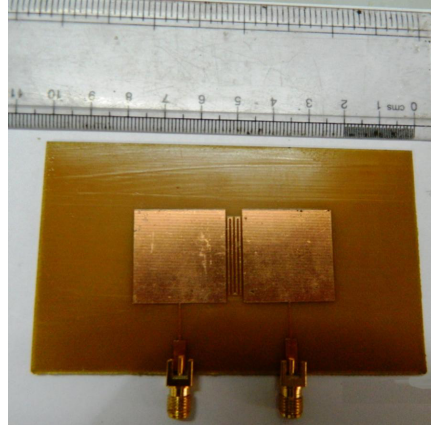

Figure 9. Fabricated prototype of proposed design.

Table 2. Performance of the proposed structure compared with previous reported designs.

Ref.	Technique	Centre Frequency (in GHz)	Edge to Edge Distance	Centre to Centre Distance	Isolation Improvement (in dB)
[9]	DGS	7.5	0.30 λ	0.45 λ	17.43
[5]	EBG	5.56	Not Reported	0.84 λ	4
[7]	UC-EBG	5.75	0.50 λ	0.76 λ	10
[8]	Compact EBG	2.4	0.47 λ	0.8 λ	17
[10]	U-shaped resonator	2.44	0.28 λ	0.6 λ	6–10
[11]	Slotted Meander Line Resonator	4.8	0.11 λ	0.38 λ	6–16
[13]	Slot in Ground plane	5.8	0.031 λ	0.33 λ	40
[14]	SCSRR	5	0.25 λ	0.50 λ	10
[15]	SCSSRR	3.7	0.125 λ	0.67 λ	14.6
[17]	Waveguide MTM	3.525	0.125 λ	0.37 λ	6–20
[19]	Waveguide MTM	2.446	0.093 λ	0.422 λ	18 (<i>E</i> Plane) 9 (<i>H</i> Plane)
[12]	I-shaped resonator	3.95	0.18 λ	0.45 λ	30
Proposed Work	Meander line resonator	2.8	0.056 λ	0.28 λ	8–10

are denoted by P_θ and P_ϕ . Assuming uniform propagation as mention in [20], we can write $XPR=1$ and $P_\theta = P_\phi = \frac{1}{4\pi}$. It reduces Equation (2) to

$$\rho_{12} = \left| \frac{\iint E_{\theta 1}(\Omega) E_{\theta 2}^*(\Omega) + E_{\phi 1}(\Omega) E_{\phi 2}^*(\Omega) d\Omega}{\sqrt{\iint (G_{\theta 1}(\Omega) + G_{\phi 1}(\Omega)) d\Omega \iint (G_{\theta 2}(\Omega) + G_{\phi 2}(\Omega)) d\Omega}} \right|^2 \quad (3)$$

By the help of Equation (3), envelope correlation coefficient is computed and shown in Figure 7. It is shown that the proposed design has less correlation coefficient than the reference one at the operating frequency.

The normalized radiation pattern of antenna is shown in the Figure 8. It is shown that there is no change in the co-polar radiation pattern and acceptable cross polar performance has been obtained which is below -15 dB with respect to co-polar radiation pattern in both E -plane and H -plane. Figure 9 shows the fabricated prototype of the proposed antenna structure.

Table 2 demonstrates a comparison of diversely reported technique from the isolation point of view. DGS [9] or slot in the ground plane [13] reported maximum isolation between two elements, yet it deteriorated radiation pattern. EBG [5, 6], UC-EBG [7, 8] and WGMTM [17–19] are the most appealing choice to reduce surface wave coupling between two elements, without affecting radiation pattern, but it increase design difficulties a lot. It is seen from our design by using a simple structure, a very minimum edge to edge distance in between the radiating patch has been observed compared with all other reported designs.

4. CONCLUSION

In this paper, Mutual Coupling reduction using meander line resonator between two patch antennas has been demonstrated. With edge-to-edge spacing of 6 mm ($\lambda/18$) an enhancement of 8–10 dB isolation at the operating frequency is achieved. A comparative study report showing Mutual Coupling reduction in respect of common design parameters as reported in various techniques has been furnished in Table 2. The measured results are also found to be in good agreement with the simulated ones. The proposed design may have its footprint in MIMO, RFID technology and Radar applications.

REFERENCES

1. Balanis, C., *Antenna Theory: Analysis and Design*, Wiley Inter science, Hoboken, NJ, 2005.
2. Van Lil, E. H. and A. R. Van de Capelle, "Transmission-line model for mutual coupling between microstrip antennas," *IEEE Transaction on Antennas Propagation*, Vol. 32, No. 8, 816–821, 1984.
3. Malkomes, K., "Mutual coupling between microstrip patch antennas," *Electronic Letters*, Vol. 18, No. 12, 520–522, 1982.
4. Penard, E. and J. P. Daniel, "Mutual coupling between microstrip antennas," *Electronics Letters*, Vol. 18, No. 14, 605–607, 1982.
5. Yu, A. and X. Zhang, "A novel method to improve the performance of microstrip antenna arrays using a dumbbell EBG structure," *IEEE Antennas Wireless Propagation Letters*, Vol. 2, No. 1, 170–172, 2003.
6. Suntives, A. and R. Abhari, "Miniaturization and isolation improvement of a multiple-patch antenna system using electromagnetic band gap structures," *Microwave and Optical Technology Letters*, Vol. 55, No. 7, 1609–1612, 2013.
7. Farahani, H. S., M. Veysi, M. Kamyab, and A. Tadjalli, "Mutual coupling reduction in patch antenna arrays using a UC-EBG superstate," *IEEE Antennas Wireless Propagation Letters*, Vol. 9, 57–59, 2010.
8. Islam, M. T. and M. S. Alam, "Compact EBG structure for alleviating mutual coupling between patch antenna array elements," *Progress In Electromagnetics Research*, Vol. 137, 425–438, 2013.

9. Zhu, F. G., J. D. Xu, and Q. Xu, "Reduction of mutual coupling between closely packed antenna elements using defected ground structure," *Electronics Letters*, Vol. 45, No. 12, 601–602, 2012.
10. Farsi, S., D. Schreurs, and B. Nauwelaers, "Mutual coupling reduction of planar antenna by using a simple microstrip u-section," *IEEE Antennas and Wireless Propagation Letters*, Vol. 11, 1501–1503, 2012.
11. Alsath, M. G., M. Kanagasabai, and B. Balasubramanian, "Implementation of slotted meander line resonators for isolation enhancement in microstrip patch antenna arrays," *IEEE Antennas and Wireless Propagation Letters*, Vol. 12, 15–18, 2013.
12. Ghosh, C. K. and S. K. Parui, "Reduction of mutual coupling between E-shaped microstrip antennas by using a simple microstrip I-section," *Microwave and Optical Technology Letters*, Vol. 55, No. 11, 2544–2549, 2013.
13. OuYang, J., F. Yang, and Z. M. Wang, "Reduction of mutual coupling of closely spaced microstrip MIMO antennas for WLAN application," *IEEE Antennas Wireless Propagation Letters*, Vol. 10, 310–312, 2011.
14. Suwailam, M. M. B., O. F. Siddiqui, and O. M. Ramahi, "Mutual coupling reduction between microstrip patch antennas using slotted-complementary split-ring resonators," *IEEE Antennas Wireless Propagation Letters*, Vol. 9, 876–878, 2010.
15. Shafique, M. F., Z. Qamar, L. Riaz, R. Saleem, and S. A. Khan, "Coupling suppression in densely packed microstrip arrays using metamaterial structure," *Microwave and Optical Technology Letters*, Vol. 57, No. 3, 759–763, 2015.
16. Zuo, S. L., Y. Z. Yin, W. J. Wu, Z. Y. Zhang, and J. Ma, "Investigations of reduction of mutual coupling between two planar monopoles using $\lambda/4$ slots," *Progress in Electromagnetic Research Letters*, Vol. 19, 9–18, 2010.
17. Yang, X. M., X. G. Liu, X. Y. Zhu, and T. J. Cui, "Reduction of mutual coupling between closely packed patch antenna using waveguide metamaterials," *IEEE Antennas and Wireless Propagation Letters*, Vol. 11, 389–391, 2012.
18. Xu, H. X., G. M. Wang, and M. Q. Qi, "Hilbert-shaped magnetic waveguided metamaterials for electromagnetic coupling reduction of microstrip antenna array," *IEEE Transactions on Magnetics*, Vol. 49, No. 4, 1526–1529, 2013.
19. Qamar, Z. and H. C. Park, "Compact waveguided metamaterials for suppression of mutual coupling in microstrip array," *Progress In Electromagnetic Research*, Vol. 149, 183–192, 2014.
20. Sarkar, D., A. Singh, K. Saurav, and K. V. Srivastava, "Four-element quad-band multiple-input-multiple-output antenna employing split-ring resonator and inter-digital capacitor," *IET Microwaves Antennas & Propagation*, Vol. 9, No. 13, 1453–1460, 2015.
21. HFSS ver. 14, Ansoft Corporation, Pittsburgh.
22. Ansoft Designer ver. 2.2.0, Ansoft Corporation.