

## Simulation of Magnetic Field Topology in a Saddle-Shaped Coil of Nuclear Quadrupole Resonance Spectrometer

Andriy Samila\*

**Abstract**—A topology of high-frequency field intensity in the work area of a saddle-shaped coil for a nuclear quadrupole resonance spectrometer was studied. With a view to determine magnetic field topology, a computational domain was created which is a model of a saddle-shaped coil physical structure. Finite element method was used to perform numerical simulation in COMSOL Multiphysics software. According to the results of calculations performed and the field maps obtained, the relative volume of coil work area was determined which makes 28.12% of its full volume. For such a volume the recommended size of samples under study is  $12 \times 18 \times 10 \text{ mm}^3$ .

### 1. INTRODUCTION

At the present stage of semiconductor electronics development particular attention has been focused on layered semiconductor materials of  $A^3B^6$  group which hold promise for creation of electronic products resistant to ionizing radiation [1]. The quality of starting materials is determined by the presence of dislocations and structural defects in the layered semiconductor single crystals. One of modern and sensitive methods of studying the quality of layered semiconductors is nuclear quadrupole resonance (NQR) method [2]. Using this method permits consecutive scanning of the entire volume of layered semiconductor sample, which makes it possible to judge on crystal perfection by the obtained NQR spectra. An important technical characteristic of nuclear magnetic resonance (NMR), nuclear quadrupole resonance (NQR) and electron paramagnetic resonance (EPR) microwave spectrometers is their sensitivity which is mostly determined by the number of spins in unit volume (one cubic centimeter) of specific substance. However, in actual practice it is more convenient to estimate relative sensitivity by signal/noise ratio at spectrometer output [3].

The purpose of this paper is to determine the optimal work volume of a saddle-shaped coil for a nuclear quadrupole resonance spectrometer via creation of a 3D magnetic field model and calculation of magnetic field topology in the work area by the finite-element method.

### 2. PROBLEM FORMULATION

The  $SNR_S$  signal/noise ratio at spectrometer output is determined by the noise ratio of microwave spectrometer input stage and, primarily, by the quality of receiving coil or resonator. For the analytical estimation of  $SNR_S$  ratio of spectrometers working in very high frequency range one can use the following expression [3]:

$$SNR_S = \frac{1}{8} \cdot \left( \frac{\omega_0^3 \cdot \eta \cdot Q \cdot V_S}{2 \cdot \mu_0 \cdot k \cdot T \cdot F \cdot b_R} \cdot \frac{T_2}{T_1} \right)^{1/2} \cdot \frac{\chi_0}{\gamma}, \quad (1)$$

---

Received 23 July 2015, Accepted 6 September 2015, Scheduled 17 September 2015

\* Corresponding author: Andriy Samila (asound@ukr.net).

The author is with the Department of Radio Engineering and Information Security, Yuriy Fedkovych Chernivtsi National University, Chernivtsi 58012, Ukraine.

where  $\eta$  is filling ratio;  $Q$  is quality factor of resonance loop;  $V_S$  is sample volume;  $T_1$  and  $T_2$  are nuclear spin-lattice and spin-spin relaxation times;  $\mu_0$  is magnetic permeability of medium;  $k$  is the Boltzmann constant;  $T$  is absolute temperature;  $F$  is noise ratio of preamplifier;  $b_R$  is transmission bandwidth of microwave spectrometer amplification path;  $\chi_0$  is magnetic susceptibility of substance under study;  $\gamma$  is gyromagnetic ratio for resonating nuclei.

From expression (1) it is seen that under all other conditions with formation of  $\text{SNR}_S$  ratio of primary significance is the factor of quality of receiving coil  $\eta Q$ . The figure of merit of the coil can be improved through optimal combination of structural features, namely the number of coils, wire quality, shape configuration, inductance for given frequency, etc.

Parameter  $\eta$  is a function of coil volume filled with substance. In fact, it also depends on the homogeneity of the field where the sample is placed. That is why some effective value  $\eta'$  is introduced, which depends on the distribution of high-frequency field in the sample filling the coil. This is particularly important with pulse detection of resonance signal where maximum intensity of response signal is largely dependent on the intensity of high-frequency field in the coil ( $\mathbf{B}_1$ ) during the pulse of duration  $t_i$  and is achieved under condition [4]

$$\gamma \mathbf{B}_1 t_i = \pi/2, \quad (2)$$

where  $\pi/2$  is rotation angle of nuclear spins. In powder-like samples for NQR such an angle can be  $0.66\pi$ . In the presence of high-frequency field intensity gradient within the sample, in the process of response signal formation there is “blurring” of total vector of spin magnetization, which results in the expansion of resonance signal and the reduction of its intensity amplitude. Increase of high-frequency field uniformity is particularly important for detection of weak signals observable in the study of substances with a low natural abundance of magnetoactive nuclei. With a nonuniform high-frequency field, a complete filling of the coil with a substance under study does not result in expected signal amplification according to expression (1). So, when configuring and manufacturing the coil, the factor of quality  $\eta Q$  with regard to field uniformity is of decisive importance for optimizing the conditions of resonance signal generation.

The topology of high-frequency field intensity in solenoid coil of microwave spectrometer detector was considered in [5]. To provide a restricted zone for scanning of sample under study and more efficient interaction of high-frequency field and crystal for excitation and reception of spin induction signal, it is reasonable to use a saddle-shaped spectrometer coil (Fig. 1), where the vector of high-frequency field  $\mathbf{B}_1$  is directed normal to crystal growth direction. The use of a single-turn coil is due to the type of samples under study. The NQR spectra for instrumentally convenient spin transitions of InSe layered semiconductor crystals are in the frequency range of 30–40 MHz. Adjustment of NQR spectrometer in this range requires a low-inductance tuned-circuit coil, which is inherent in single-turn saddle-shaped coil. The signal/noise ratio for high-frequency coil can be represented by the expression [6, 7]:

$$\text{SNR} \approx \frac{\mathbf{B}_1 V \sqrt{Q} \mathbf{B}_0^{3/2}}{\sqrt{\Delta\omega}}, \quad (3)$$

where  $\mathbf{B}_1$  is magnetic field induction created by receiving coil with a unitary current in it;  $V$  is excited volume of the sample;  $Q$  is quality factor of high-frequency system;  $\mathbf{B}_0$  is induction of polarizing magnetic field;  $\Delta\omega$  is bandwidth.

The value  $\mathbf{B}_1$  governs coil sensitivity. So, the relative work volume of the coils should be maximized, for their conductors to be as close as possible to the object under study. The permissible field nonuniformity for recording of NQR with minimum distortions of resonance spectra should make 10–15% [7, 8].

To determine a magnetic field map, it is necessary to perform synthesis and create a field model of the coil. One of the first tasks when creating the field model is to determine the model geometry. For a more complete representation with regard to geometric features of a real configuration of saddle-shaped coil, its 3D model was developed (Fig. 1).

This model was developed with regard to recommendations as to geometry of saddle-shaped coils given in [7]. The total transverse component of radio-frequency coil field is determined by the field of four linear and four arc conductors:

$$\mathbf{B}_S = 4(\mathbf{B}_{YL} + \mathbf{B}_{YA}). \quad (4)$$

The transverse component of the field of 1D conductor of infinite length arranged in coordinates  $y_0, z_0$ , at point  $y, z$  is given by the expression

$$\mathbf{B}_{YL} = \frac{\mu_0 \mathbf{I} (z - z_0)}{2\pi [(y - y_0)^2 + (z - z_0)^2]}. \tag{5}$$

The field induction component of work conductor with start coordinates  $x_1 y_0 z_0$  and end coordinates  $x_2 y_0 z_0$  is defined by the expression

$$\mathbf{B}_{YL} = \frac{\mu_0 \mathbf{I} (z - z_0)}{4\pi r^2} \left( \frac{x_1 - x}{\sqrt{r^2 + (x_1 - x)^2}} - \frac{x_2 - x}{\sqrt{r^2 + (x_2 - x)^2}} \right). \tag{6}$$

The transverse component of magnetic field induction of the coil arc conductor is:

$$\mathbf{B}_{YA} = \frac{\mu_0 \mathbf{I}}{4\pi} \int_0^\varphi \frac{r_0 (x_1 - x) \cos \varphi_0}{[r^2 + r_0^2 - 2rr_0 \cos(\varphi_0 - \varphi) + (x_1 - x)^2]^{3/2}} d\varphi_0. \tag{7}$$

To improve field uniformity  $\mathbf{B}_Y$ , the optimal value of  $\Delta x$  and angular dimensions of coil arcs can be found by compensation of other derivatives of expressions for magnetic field induction of linear conductors (6) and arcs (7) with a view to remove the respective terms of power series expansion of these expressions [7].

The value of the angular dimension of arc areas is:

$$\varphi = 2 \arctg \left( \frac{y_0}{z_0} \right) = 120^\circ. \tag{8}$$

On the assumption of maximum inhomogeneity of component  $\mathbf{B}_{YA}$  of the field of 1D conductors, their length is:

$$\Delta x = 2(1,26r_0). \tag{9}$$

### 3. A MODEL OF A SADDLE-SHAPED COIL IN COMSOL MULTIPHYSICS SOFTWARE

For the calculation of 3D fields, wide application has been gained by computer programs based on finite element method, such as ANSYS, ABAQUS, COMSOL, ELCUT. Extensive use of 3D simulation is constrained by the absence of clear theoretical substantiation of the formulation of electromagnetic

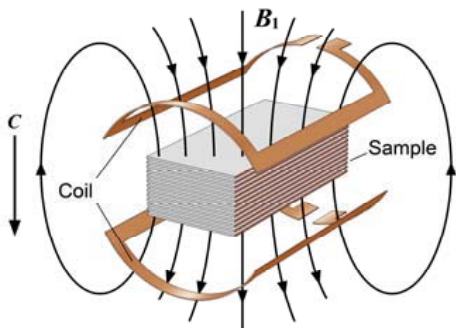

**Figure 1.** Configuration of a saddle-shaped coil with arrangement of a crystal sample of layered semiconductor therein.

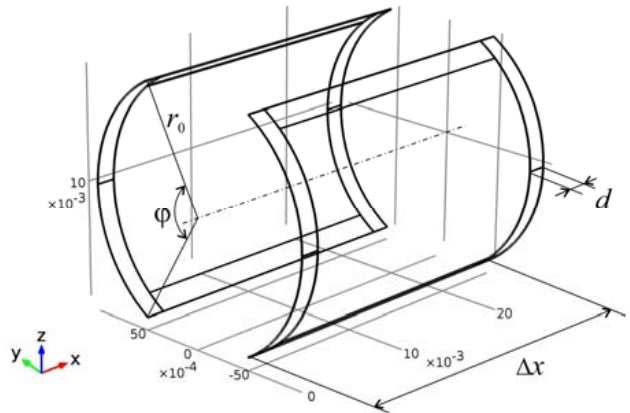
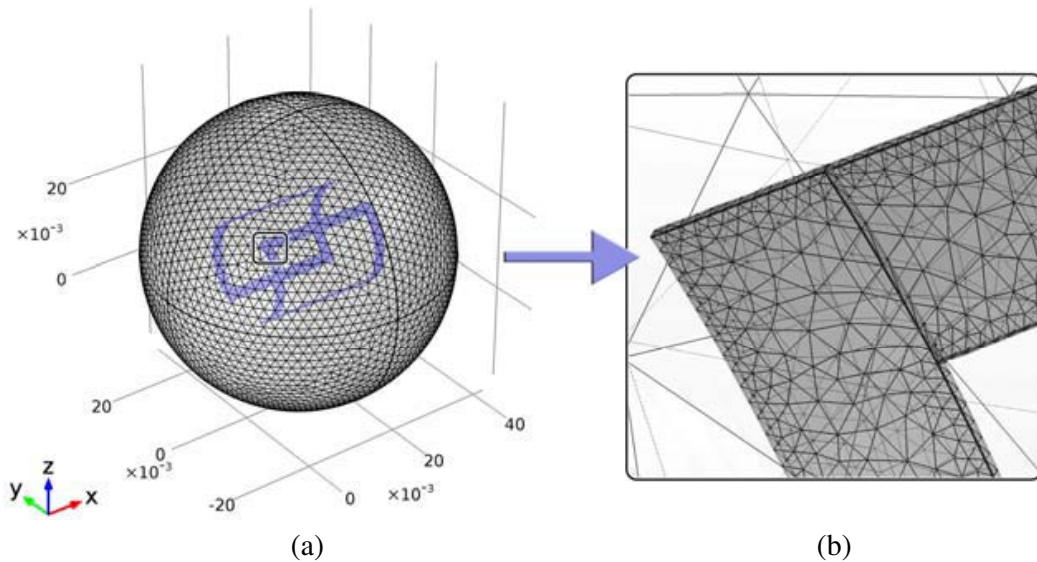

**Figure 2.** 3D image of a geometrical model of a saddle-shaped coil in COMSOL Multiphysics.

field numerical calculation problems which in some cases are beyond the scope of classical theory of electromagnetic field. First of all, this concerns the formulation of problems of electromagnetic field calculation with respect to vector magnetic and scalar electric potentials [9]. Magnetic field topology of a saddle-shaped coil was analyzed in COMSOL Multiphysics V 4.4, which offers vast opportunities in the field of simulation of electromagnetic, thermal, mechanical, acoustic and other fields [10]. The problem of magnetic field calculation was formulated with respect to vector magnetic potential  $\mathbf{A}$  [11]. Taking into account the original dimensions of samples under study and the relations (8) and (9), a computational domain was created which is a model of physical structure of a saddle-shaped coil for which the numerical simulation is done. The model describes a system of coil with the following parameters: radius  $r_0 = 10$  mm, length  $\Delta x = 25.2$  mm, opening angle of arc areas  $\varphi = 120^\circ$  (Fig. 2). Copper with the electric conductivity  $\sigma = 5.998 \cdot 10^{-7}$  S/m and relative magnetic permeability  $\mu_r = 0.99999$  was selected as material for coil conductors.

In the development of this model the following initial conditions were assumed. This model was developed under the following assumptions. As long as the coil is to be made according to planar technology, by etching flat copper turns on the surface of thin PCB laminate material, the winding is considered to be single-turn, realized by a conductor of cross-section  $1 \cdot 10^{-4} \times 1.6 \cdot 10^{-3}$  m. To simplify the analysis, coil turns are represented as closed perimeters with direct current flowing along them, and the influence of attached conductors is excluded. Current flow direction  $I_{\text{coil}}$  is simulated along the reference edges established for each coil turn. The area of magnetic field simulation is restricted by air sphere of electric conductivity  $\sigma = 0$  S/m and relative magnetic permeability  $\mu_r = 1$ . Sphere radius is  $R = 3 \cdot 10^{-2}$  m, air temperature and pressure are assumed to be  $T = 293.15$  K and  $P = 1$  atm, respectively. On the external boundary of the computational region the boundary conditions were specified by the Dirichlet condition represented in the differential form. This allowed ignoring scattering fluxes that are closed through the air gap on the external boundary of the computational region by specifying magnetic isolation condition which by default in COMSOL Multiphysics is of the form  $\mathbf{n} \times \mathbf{A} = 0$ .

Calculation of magnetic field topology was done in *Magnetic Fields (mf)* module. As a result of triangulation of computation domain, finite element mesh was created with multiplexing in the area of field with maximum gradients (Fig. 3). Mesh size was chosen optimal with regard to the fact that its increase reduces the accuracy of simulation, and its decrease causes errors due to rounding of numbers in computer. Moreover, setting of minimum mesh size calls for essential expenditures of hardware computing power.



**Figure 3.** Finite element mesh was obtained due to triangulation of computational domain: (a) general view, (b) detailed representation of coil fragment.

In COMSOL Multiphysics a map of static magnetic fields can be calculated by solving a magnetostatic equation obtained from Ampere’s law for static cases.

$$\nabla \times \mathbf{H} = \mathbf{J}, \tag{10}$$

where  $\nabla$  is differential Hamiltonian operator,  $\mathbf{H}$  is magnetic field intensity,  $\mathbf{J}$  is the amplitude of total electric-current density. The relations between magnetic field intensity  $\mathbf{H}$  and magnetic flux density (induction)  $\mathbf{B}$  are given by the dependences:

$$\mathbf{B} = \nabla \times \mathbf{A}; \tag{11}$$

$$\mathbf{H} = \mu_0^{-1} \mu_r^{-1} \mathbf{B}. \tag{12}$$

Taking into account the value of relative magnetic permeability for copper and the definition of vector potential of magnetic field  $\mathbf{A}$ , we can write the resulting differential magnetostatic equation as a modified Ampere’s law:

$$\nabla \times (\mu_0^{-1} \mu_r^{-1} \nabla \times \mathbf{A}) - \sigma \nu \times (\nabla \times \mathbf{A}) = \mathbf{J}_e, \tag{13}$$

where  $\mu_0$  is the magnetic permeability of vacuum,  $\mu_r$  the relative magnetic permeability of copper,  $\sigma$  the electric conductivity,  $\nu$  the motion velocity, and  $\mathbf{J}_e$  the the amplitude of external current density.

The values of external current density are determined only in the model zones that represent a saddle-shaped inductance coil and are determined through current flowing along its perimeter:

$$\mathbf{J}_e = \frac{\mathbf{I}_{\text{coil}}}{S}, \tag{14}$$

where  $\mathbf{I}_{\text{coil}}$  is given current, and  $S$  is the cross-sectional area of coil perimeter.

#### 4. SIMULATION RESULTS

Processing of numerical simulation results was done by embedded COMSOL tools with the aid of the objects and options of “Results” item. This item automatically creates the objects necessary for graphical representation of results on completion of calculation, “Graphics” window shows graphical representation of numerical simulation results. Representation parameters were assigned depending on the representation of graphical results.

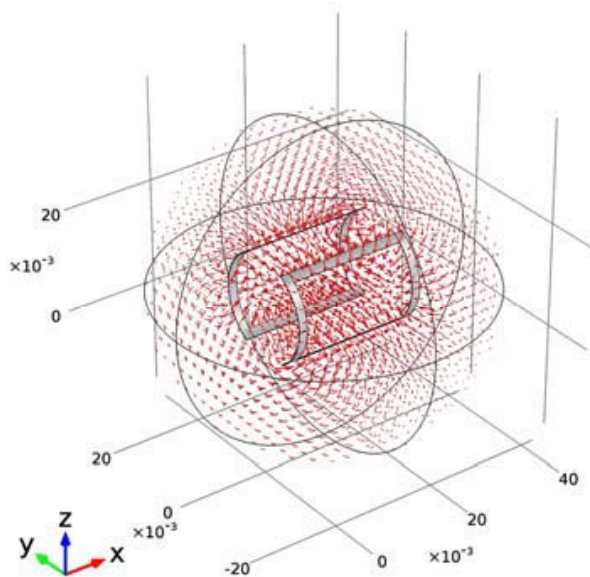

**Figure 4.** Magnetic field lines in the computational domain of a saddle-shaped coil.

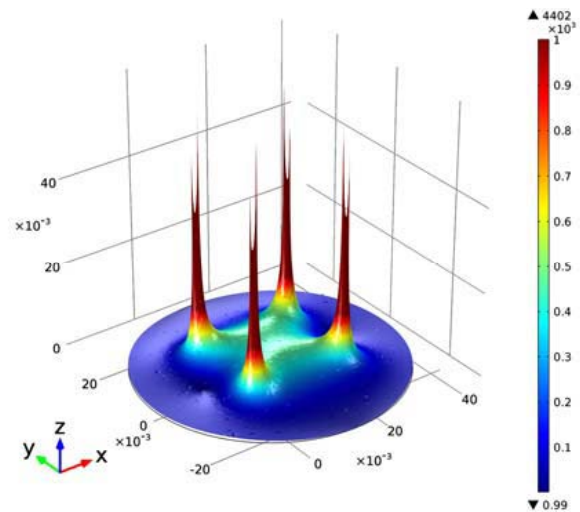

**Figure 5.** 3D topology of magnetic field intensity in  $XY$  plane of a saddle-shaped coil.

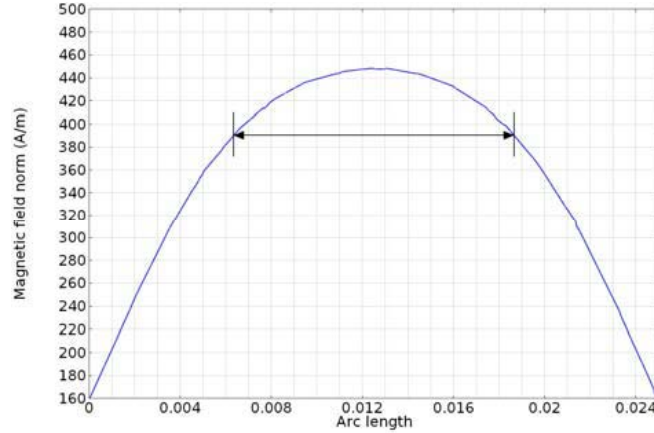

**Figure 6.** Magnetic field intensity along the axis  $x$  of a saddle-shaped coil.

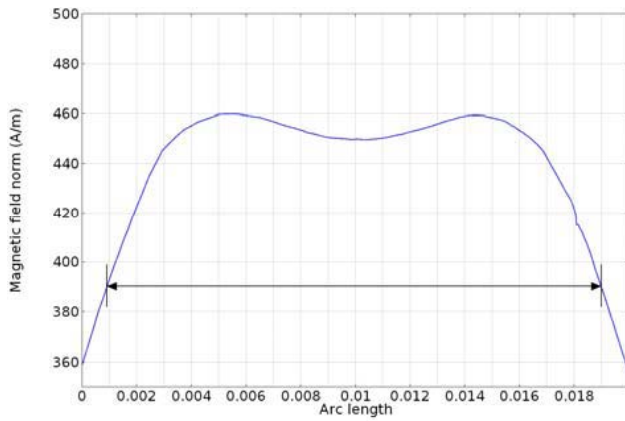

**Figure 7.** Magnetic field intensity along the axis  $y$  of a saddle-shaped coil.

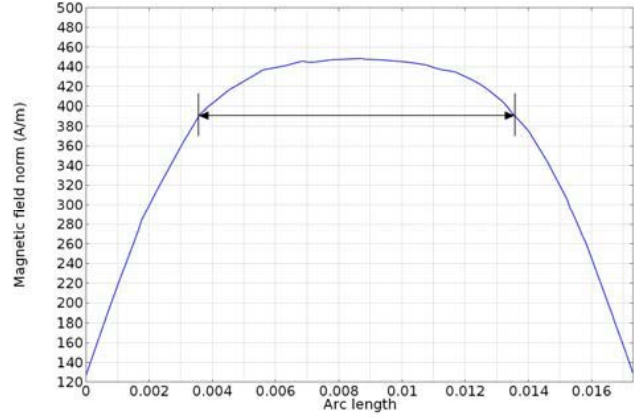

**Figure 8.** Magnetic field intensity along the axis  $z$  of a saddle-shaped coil.

The result of field topology simulation in a saddle-shaped coil with direct current flow  $I_{\text{coil}} = 10$  is shown in Fig. 4 as magnetic field lines (lines of equal magnetic potential). The simulation was done with regard to the boundary conditions describing magnetic field distribution at the boundaries of computational domain. 3D topology of magnetic field intensity in  $XY$  plane is represented in Fig. 5. From this figure it is seen that in the work area of coil under study there is a zone with a uniform distribution of the field, and for a more detailed study of its geometry it is necessary to process the results for individual sections of computational domain.

Detailed simulation results for geometric axes  $x$ ,  $y$ ,  $z$  are represented by 1D plots (Fig. 6–Fig. 8). The dependences of magnetic field intensity distribution represented in these figures show that the zones of permissible field nonuniformity (not more than 15%) on either side of the geometrical centre of a saddle-shaped coil are: 12.3 mm along the  $x$  axis, 18.1 mm along the  $y$  axis, and 10 mm along the  $z$  axis.

According to the results of calculations performed and the field maps obtained, the relative volume of coil work area was determined which makes 28.12% of its full volume. For such a volume the recommended size of samples under study is  $12 \times 18 \times 10 \text{ mm}^3$ .

## 5. CONCLUSIONS

To provide a restricted zone for scanning of a layered semiconductor sample and a more efficient interaction of high-frequency field and crystal, an optimal work volume of a saddle-shaped coil of NQR-spectrometer was studied by the calculation of magnetic field topology in the coil work zone using

finite element method.

1. Taking into account the original geometrical dimensions of samples under study, a computational domain was created which is a model of physical structure of a saddle-shaped coil of length  $\Delta x = 25.2$  mm, radius  $r_0 = 10$  mm and opening angle of arc areas  $\varphi = 120^\circ$ .

2. A numerical simulation in COMSOL Multiphysics software was done, and 2D and 3D maps of static magnetic field intensity distribution of a saddle-shaped coil were calculated.

3. It is established that for a one-turn saddle-shaped coil with the above geometric parameters the recommended size of samples studied by NQR method is  $12 \times 18 \times 10$  mm<sup>3</sup> which is 28.12% of full coil volume.

## REFERENCES

1. Kyazym-Zade, A. G., A. A. Agaeva, V. M. Salmanov, and A. G. Mokhtari, "Optical detectors on GaSe and InSe layered crystals," *Technical Physics*, Vol. 52, No. 12, 1611–1613, 2007.
2. Khandozhko, V., N. Raranskii, V. Balazjuk, Z. Kovalyuk, and A. Samila, "Temperature and baric dependence of nuclear quadruple resonance spectra in indium and gallium monoselenides," *Proceedings of SPIE*, Vol. 9066, 90661G–7, 2013.
3. Schneider, H. and P. Dullenkopf, "Slotted tube resonator: A new NMR probe head at high observing frequencies," *Review of Scientific Instruments*, Vol. 48, No. 1, 68–73, 1977.
4. Grechishkin, V. S. and N. Ya. Sinyavskii, "Remote nuclear quadrupole resonance in solids," *Physics-Uspokhi (Advances in Physical Sciences)*, Vol. 36, No. 10, 980–1003, 1993.
5. Brailovskyy, V. V., A. P. Samila, and O. G. Khandozhko, "Topology of high-frequency field strength of microwave spectrometer sensor coil," *Visnyk of Lviv Polytechnic National University*, No. 646, 46–51, 2009 (in Ukrainian).
6. Hoult, D. I., "The NMR receiver: A description and analysis of design," *Progress in NMR Spectroscopy*, Vol. 12, No. 1, 41–77, 1978.
7. [http://open.ifmo.ru/images/b/b6/144261\\_book.pdf](http://open.ifmo.ru/images/b/b6/144261_book.pdf).
8. Marrocco, B. J. D., D. J. Drost, and F. S. Prato, "An optimized head coil design for MR imaging at 0.15 T," *Magnetic Resonance in Medicine*, Vol. 5, No. 2, 143–159, 1987.
9. Glukhenkyi, O. I., Yu. M. Goryslavets, and A. V. Tokarevskiy, "Three-dimensional simulation of single-phase electromagnetic stirrer of liquid metal," *Technical Electrodynamics*, No. 5, 77–84, 2013 (in Russian).
10. <http://www.comsol.com/>.
11. Glukhenkyi, O. I. and Yu. M. Goryslavets, "Scalar electric and vector magnetic potentials in theory of electromagnetic field," *Technical Electrodynamics*, No. 2, 7–8, 2012 (in Russian).