

A Planar UWB Antenna with Triple-Notched Bands Using Triple-Mode Stepped Impedance Resonator

Shaoming Pan¹, Gongkun Luo¹, Baozhong Ke¹, and Kejian Li^{1, *}

Abstract—A planar ultra-wideband (UWB) antenna with triple-notched bands using triple-mode stepped impedance resonator (SIR) is presented in this paper. By coupling the novel triple-mode SIR beside the microstrip feedline, band-rejected filtering properties around the C-band satellite communication band, the 5.8 GHz WLAN band, and the X-band satellite communication band are generated. The notched frequencies can be adjusted according to specification by altering the triple-mode SIR. The results indicate that the proposed planar antenna not only retains an ultra wide bandwidth but also owns triple band-rejections capability. The UWB antenna demonstrates omnidirectional radiation patterns across nearly whole operating bandwidth, which is suitable for UWB communications.

1. INTRODUCTION

Ultra-wideband (UWB) radio technology has attracted much attention since the US Federal Communications Commission (FCC) allocated a frequency range with a bandwidth of 7.5 GHz (3.1~10.6 GHz) for unlicensed radio applications. Many applications have been developed based on UWB technology such as short-range broadband communication, radar sensing, and body-area networking [1]. It is a well-known fact that planar monopole antennas present attractive features, such as simple structure, small size, low cost, stable radiation patterns, and constant gain over the entire operating band. Owing to these characteristics, planar monopoles are attractive for use in emerging UWB applications, and research activity is increasingly focused on them [2–5].

However, the existing wireless networks such as IEEE 802.16 WiMAX system operating at C-band (3.7~4.2 GHz) satellite communication systems (CSCS) signals, the wireless local area network (WLAN) for IEEE802.11a operating at 5.15~5.35 GHz/5.725~5.825 GHz, and X-band (3.7~4.2 GHz) satellite communication systems (XSCS) signals can interfere with UWB systems, thus compact UWB monopole antennas with multiple notched-bands are emergently required to reject these unwanted interfering signals [6–12]. To achieve desired band-notched performance, slots such as U-shaped, V-shaped, etc. are usually inserted on initial the UWB monopole antenna in [7, 8], however, only one notched band is created. In [9, 10], two notched bands can be introduced using defected ground structure (DGS), however, they are all based on multi-layer structure that would increase fabrication cost and hardly compatible with the existing microwave-integrated circuit. In [11, 12], two notched bands can also be obtained and these antenna structures are very simple and easy to fabricate, however, they use two or three single-mode resonators. Then, the spurious notched bands obtained by spurious resonances of the conventional resonance structures [13, 14].

In this paper, a planar UWB antenna with triple-notched bands based on triple-mode stepped impedance resonator (SIR) is presented. Firstly, the resonance properties of the triple-mode SIR are

Received 4 May 2015, Accepted 25 August 2015, Scheduled 19 August 2015

* Corresponding author: Kejian Li (elenuestc@163.com).

¹ The authors are with School of Electrical and Information Engineering, Guangxi University of Science and Technology, Liuzhou 545006, China.

studied. The analyzed results reveal that triple band-stop performance can be obtained based on the triple-mode resonant property of the triple-mode SIR. Then, the triple notched-bands characteristic is achieved by putting the triple-mode SIR near by the feed line of the UWB antenna. Notice that the spurious notched-band of the triple-mode SIR is also far away from the UWB antenna work band. To validate the design concept, a novel planar UWB antenna with triple sharply rejected notched bands respectively centered at frequencies of 4.2 GHz, 5.8 GHz and 8.0 GHz is designed and fabricated. The simulation and the measurement show that the antenna achieves an ultra wide bandwidth ranging from 2.0 GHz to 11.0 GHz and avoids the CSCS /WLAN/ XSCS interference. An omni directional pattern across the entire bandwidth in the H -plane of the antenna is achieved.

2. UWB ANTENNA CONFIGURATION

The geometry of the proposed UWB antenna triple-notched bands is shown in Figure 1. It can be seen that the antenna is composed of a triple band-stop filter and a conventional planar circular monopole antenna. It is fabricated on Rogers 4350B microwave substrate of thickness 0.508 mm and relatively permittivity 3.48. The band-stop filter (i.e., the triple notched-bands) is realized by coupling the

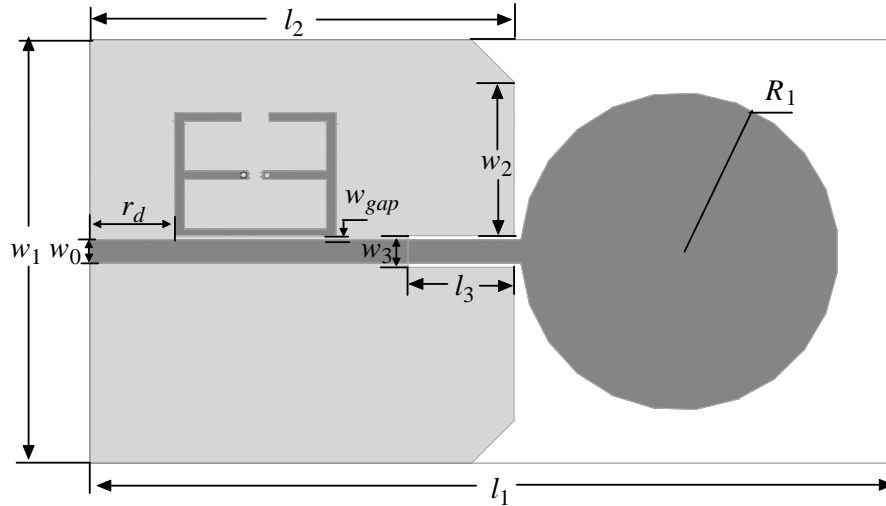

Figure 1. Layout of the proposed UWB antenna with triple notched-bands.

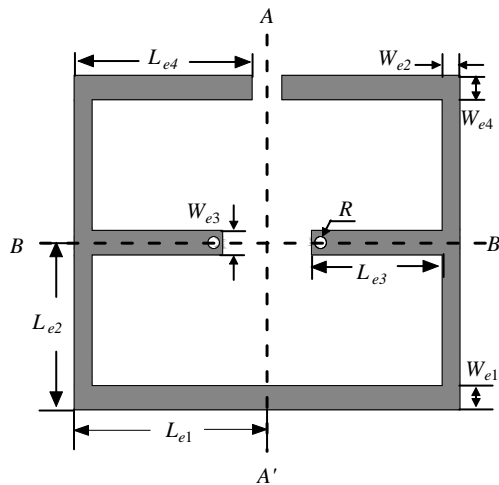

Figure 2. Geometry of the proposed triple-mode SIR.

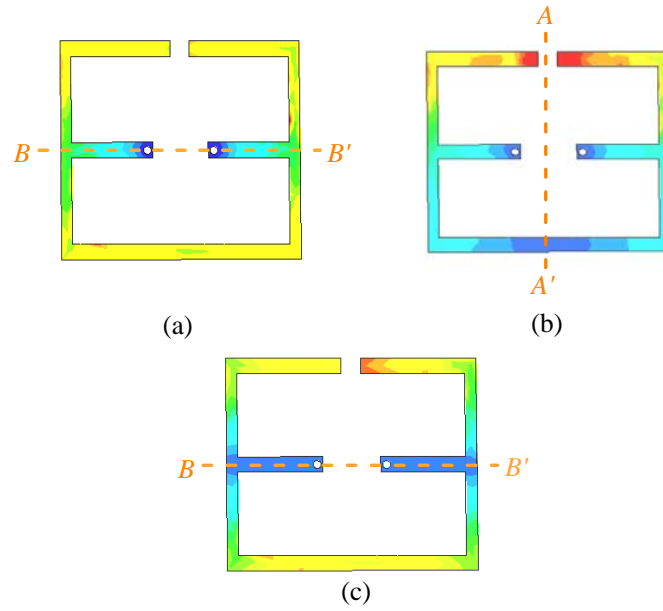

Figure 3. Electrical field distribution of the proposed triple-mode SIR: (a) even mode, (b) odd mode, (c) odd mode.

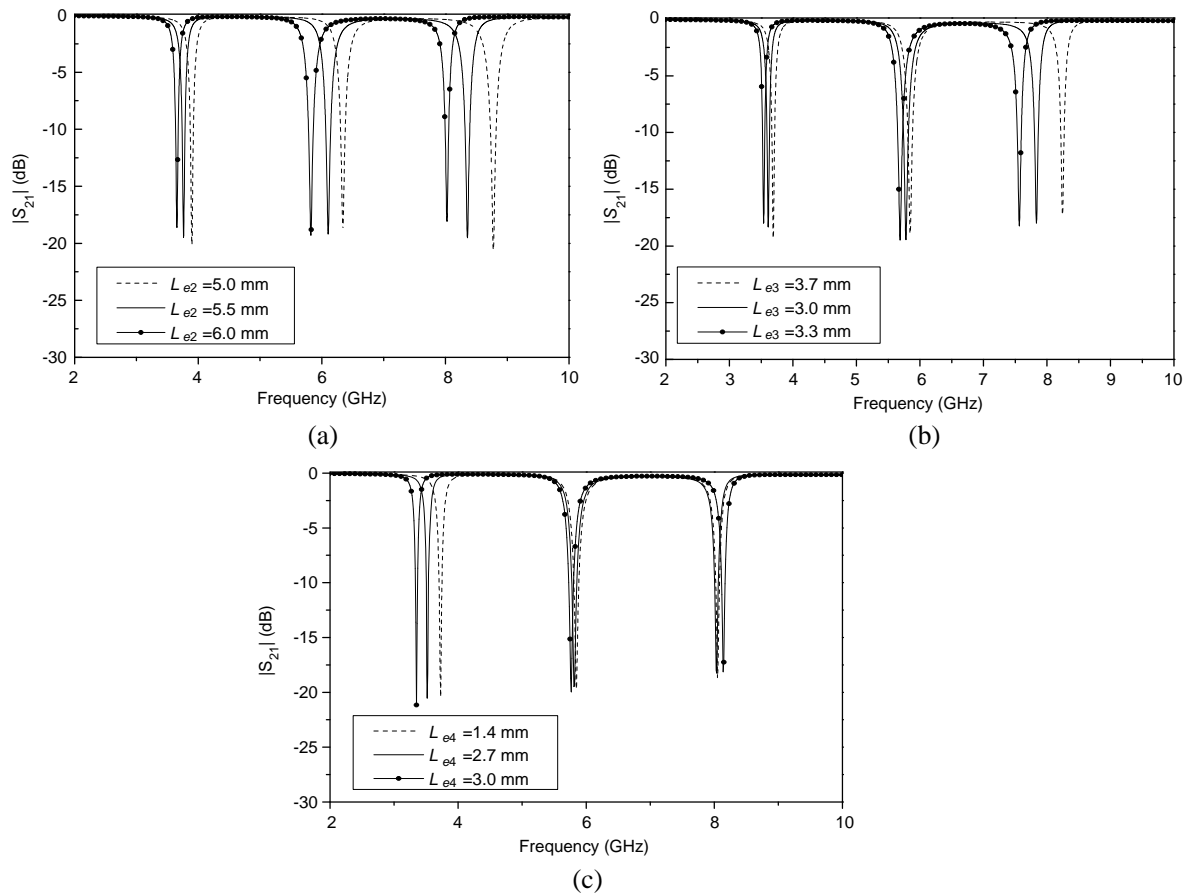
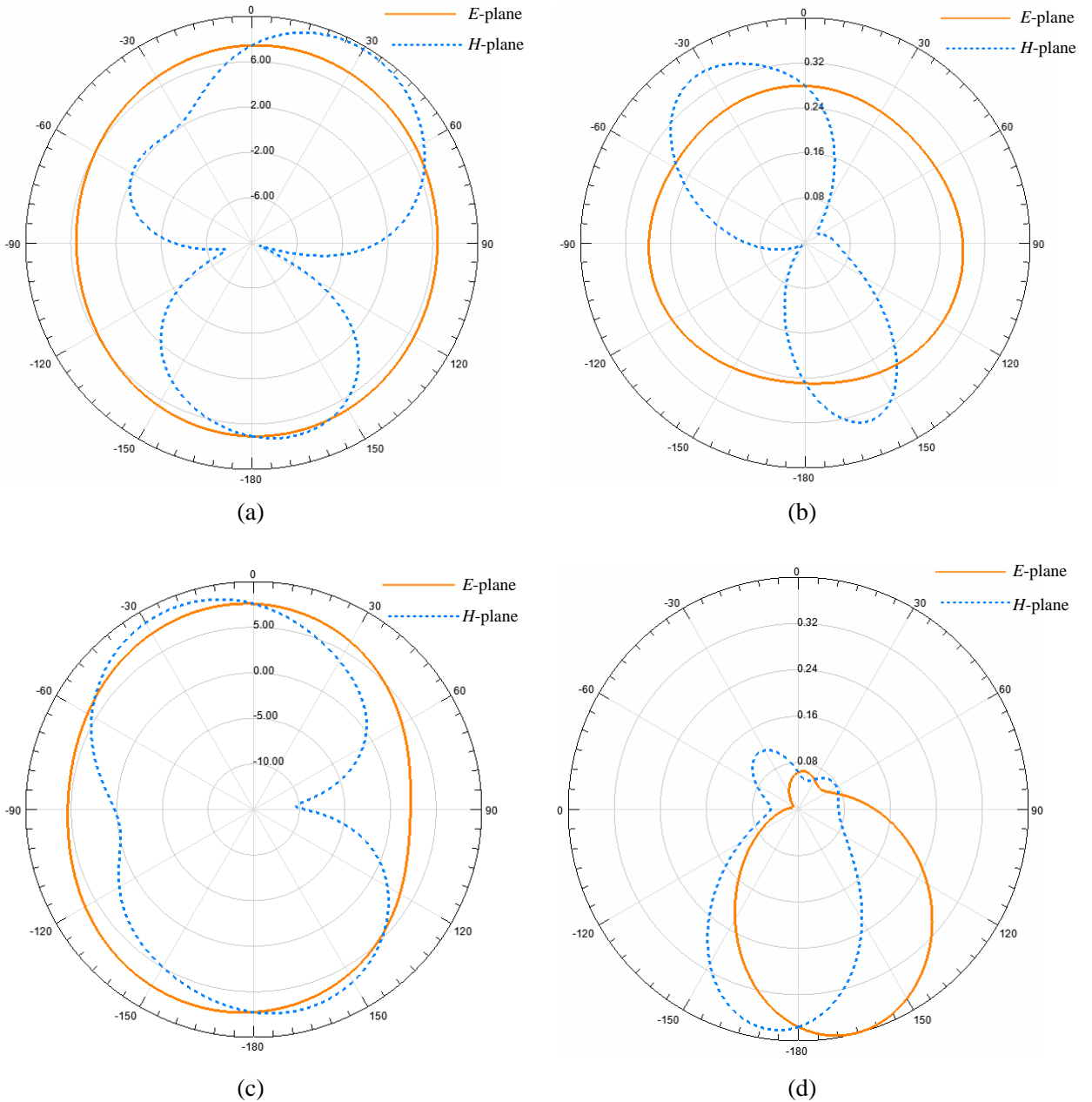

Figure 4. Simulated S -parameters of the coupled triple-mode SIR for various dimensions: (a) L_{e2} , (b) L_{e3} , (c) L_{e4} .

triple-mode SIR to $50\ \Omega$ microstrip feed-lines. The design of triple-notched bands will be discussed in Section 3. The proposed planar UWB antenna has a circular patch with radius $R_1 = 7.5$ mm, which is fed by $50\ \Omega$ microstrip line of width $w_0 = 1.1$ mm. In order to improve impedance matching performance, a rectangular slit is embedded in the ground plane, located under the microstrip feed line. The final optimized parameters of the planar UWB antenna are as follows: $w_1 = 20$ mm, $w_2 = 7.25$ mm, $w_3 = 1.5$ mm, $l_1 = 38$ mm, $l_2 = 20$ mm, $l_3 = 5.0$ mm, $r_d = 4.0$ mm, $w_{gap} = 0.1$ mm.

3. CHARACTERISTICS OF THE NOTCHED ANALYSIS

Figure 2 shows the geometry of the proposed triple-mode SIR. The proposed triple-mode SIR is composed of a stepped impedance hairpin resonator and two short-ended stubs. Since the resonator is symmetrical to the $A-A'$ and $B-B'$ plane, the resonance properties of the triple-mode SIR can be analyzed by the even-odd modes analysis method. Under mode excitation, the resonator electrical field



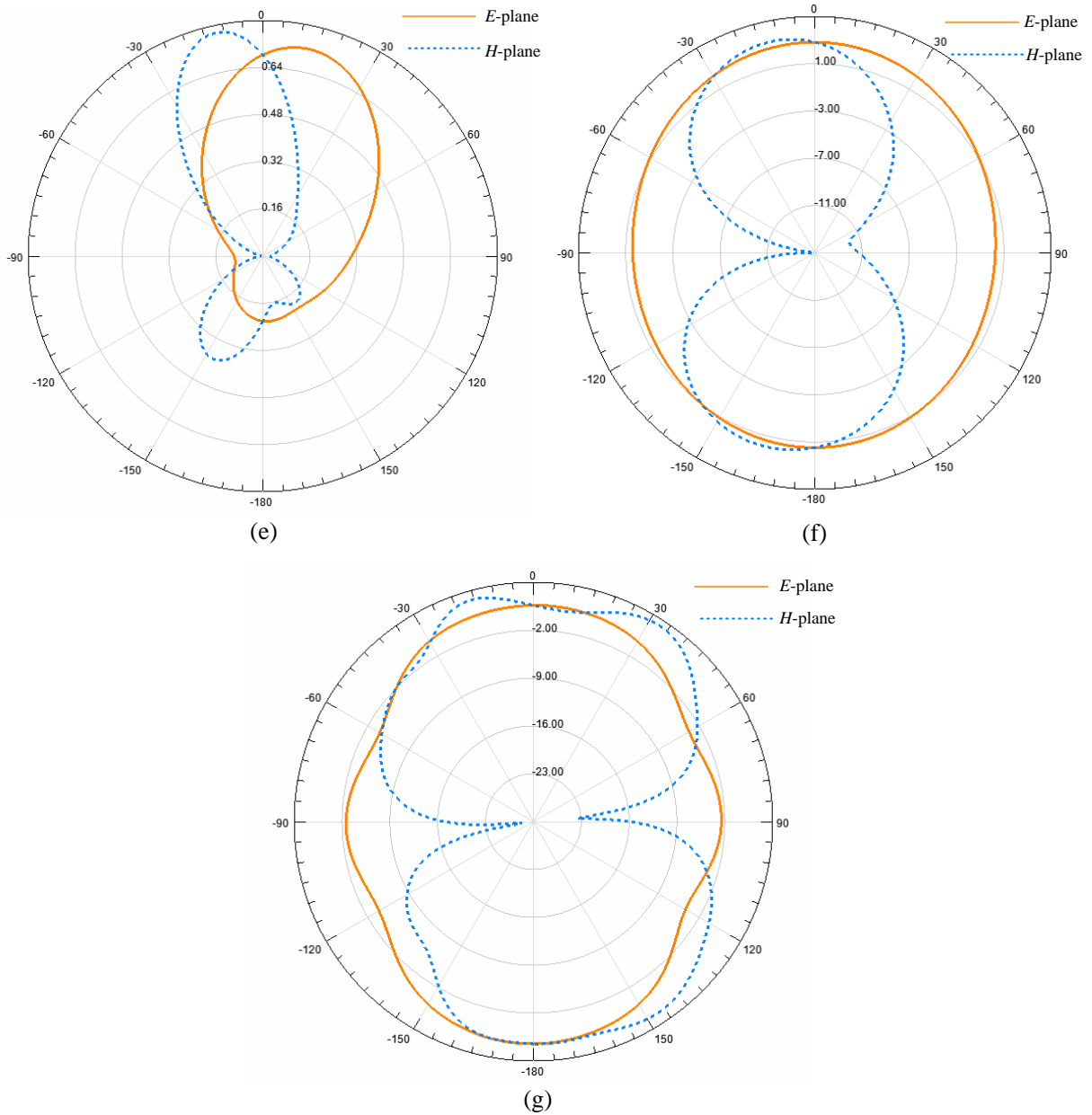

Figure 5. Measured radiation pattern of the UWB planar monopole antenna: (a) 2.5 GHz, (b) 4.2 GHz, (c) 5.0 GHz, (d) 5.2 GHz, (e) 6.8 GHz, (f) 7.5 GHz, (g) 10.0 GHz.

distribution of the resonator exhibits either an even or an odd mode distribution property as shown in Figure 3. For the even mode condition, the electrical fields exhibit a symmetric distribution along the $B-B'$ axis as shown in Figure 3(a). While for the odd mode, the electrical fields exhibit an anti-symmetric distribution along the $A-A'$ axis as shown in Figure 3(b) and the $B-B'$ axis as shown in Figure 3(c). Thus, based on the electrical field distribution property, the even-odd modes resonance frequencies can be deduced as:

$$f_{notch} = \frac{c}{\lambda_{notch} \sqrt{\epsilon_{eff}}} \tag{1}$$

$$f_{notch-even1} = \frac{c}{4(L_{e2} + L_{e3} + L_{e4}) \sqrt{\epsilon_{eff}}} \tag{2}$$

$$f_{notch-odd1} = \frac{c}{2(L_{e1} + 2L_{e2} + L_{e4})\sqrt{\varepsilon_{eff}}} \quad (3)$$

$$f_{notch-odd2} = \frac{c}{4(L_{e2} + L_{e4})\sqrt{\varepsilon_{eff}}} \quad (4)$$

where λ_{notch} is the wavelength of the center frequency of the notched band, f_{notch} the center frequency of the notched band, ε_{eff} the effective dielectric constant, and c the light speed in free space.

The triple-mode SIR can result in triple band-stop (i.e., the triple notched-bands) performance when placed next to the microstrip line and it can be equivalent to three shunt-connected series resonance circuits. In this paper, the triple-mode SIR dimensions are selected as follows: $w_{e1} = 0.4$ mm, $w_{e2} = 0.3$ mm, $w_{e3} = 0.4$ mm, $w_{e4} = 0.4$ mm, $l_{e1} = 6.5$ mm, $l_{e2} = 5.5$ mm, $l_{e3} = 2.8$ mm, $l_{e4} = 3.0$ mm, $R = 0.1$ mm.

The frequency characteristics of the triple-mode SIR with various dimensions are investigated by HFSS 11.0 to validate the multi-mode resonant property as shown in Figure 4. It can be seen that the frequency locations of the triple notched bands move down simultaneously as increase the dimensions of L_{e2} . But only the first notched band increases as decreases L_{e4} and the third notched band increases as decreases L_{e3} . Therefore, by appropriately adjusting the resonator dimensions, triple notched bands can be achieved at desired frequencies.

4. UWB ANTENNA WITH TRIPLE-NOTCHED BANDS

Based on the triple band-stop filter previously described, a novel UWB planar monopole antenna with triple sharply rejected notched bands is proposed and designed. All simulations have been carried out using Ansoft HFSS 11.0 simulation software based on the finite element method (FEM). The normalized radiation patterns in the E - and H -planes are measured at 2.5 GHz, 4.0 GHz, 5.0 GHz, 5.2 GHz, 6.8 GHz, 7.5 GHz, and 10.0 GHz as in Figure 5. It can be found that the antenna has good omni directional radiation patterns in the H -plane (dotted). The radiation patterns in the E -plane (continuous) are in symmetry. Simulated and measured VSWR of the UWB antenna as shown in Figure 6 for comparison. We can notice that the UWB antenna possesses the impedance bandwidth from 2.0 GHz to 11.0 GHz for $VSWR < 3$ except in notched bands from 4.09~4.27 GHz, 5.81~6.05 GHz, and 7.94~8.12 GHz, respectively. The central frequencies of the notched-bands are about 4.2 GHz, 5.8 GHz, and 8.0 GHz, as well as the notch frequencies of the filter designed in Section 3. The notched-bands are very suitable to implement the rejection of 4.2 GHz C-band satellite communication systems (CSCS) signal, 5.8 GHz wireless local area networks (WLAN) signal, and 8.0 GHz X-band satellite communication systems (XSCS) signal. The deviations of the measurements from the simulations are expected mainly due to

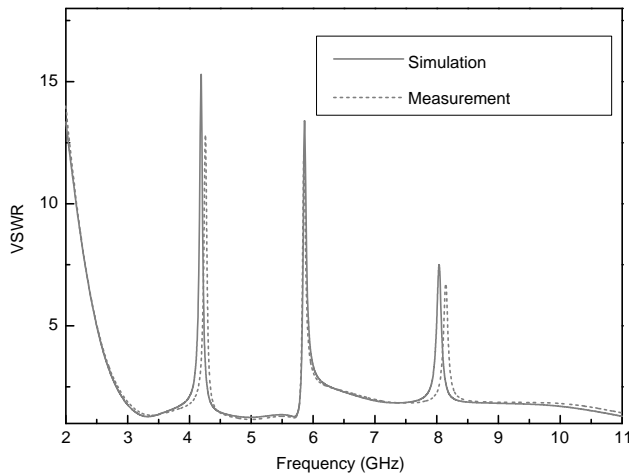

Figure 6. Measurement and simulation of VSWR.

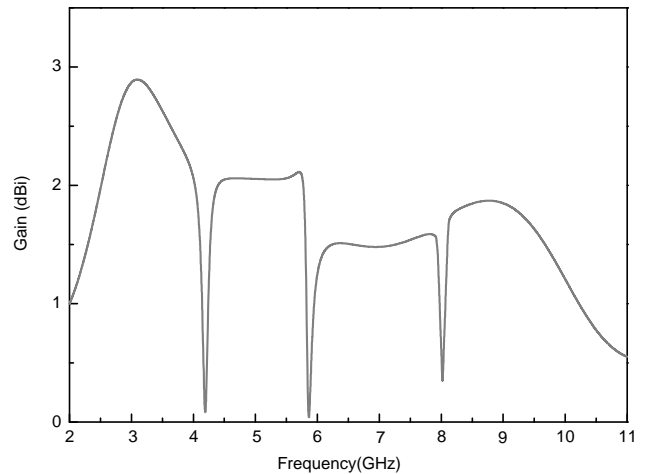

Figure 7. Measured peak gain of the proposed UWB antenna with triple-notched.

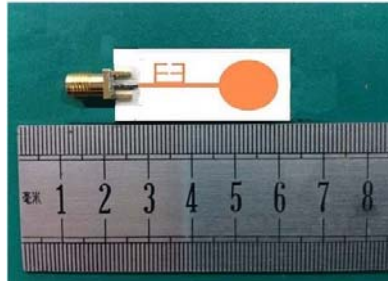

Figure 8. Photograph of the fabricated UWB antenna with triple-notched bands.

the reflections from the connectors and the finite substrate. The measured peak gain in the E -plane is given in Figure 7. The proposed antenna exhibits three significant antenna gain decreases at 4.21, 5.84, and 8.05 GHz; this is indicative of the effect of the notched bands. Figure 8 shows the photograph of the fabricated planar UWB antenna with triple-notched bands. The overall size is about $38 \times 20 \text{ mm}^2$.

5. CONCLUSION

In this work, a high-performance UWB planar monopole antenna, with triple highly rejected notched-bands, has been successfully implemented and investigated. The triple notched-bands can be easily tuned to the desirable frequency location by controlling the parameters of the proposed triple-mode SIR. The proposed antenna covers the frequency range for the UWB systems, between 2.0 GHz and 11.0 GHz, with a rejection band around CSCS, WLAN, and XSCS services. The introduced triple-mode SIR is simple and flexible for blocking undesired narrow band radio signals appeared in UWB band. Using the advantage of small real estate, outstanding performance can be realised for broadband antennas, which are now widely demanded in UWB applications. The measured results show good performance in terms of the reflection coefficient, antenna gain and radiation patterns. To summarise, the proposed planar monopole antenna is very useful for modern UWB wireless communication systems owing to its marked properties of simple topology, compact size, and excellent performance.

ACKNOWLEDGMENT

This work was supported by the Guangxi Province Natural Science Foundation of China under Grant No. 2014GXNSFAA118392 and Educational Commission of Guangxi Province under Grant No. YB2014209.

REFERENCES

1. Revision of Part 15 of the Commission's Rules Regarding Ultra-Wideband Transmission Systems, First Note and Order Federal Communications Commission, ET-Docket 98-153, 2002.
2. Naghshvarian-Jahromi, M., "Novel wideband planar fractal monopole antenna," *IEEE Trans. Antennas Propag.*, Vol. 56, No. 12, 3844-3849, 2008.
3. Naser-Moghadasi, M., H. Rousta, and B. S. Virdee, "Compact UWB planar monopole antenna," *IEEE Antennas Wirel. Propag. Lett.*, Vol. 8, 1382-1385, 2009.
4. Mazinani, S. M. and H. R. Hassani, "A novel broadband plate-loaded planar monopole antenna," *IEEE Antennas Wirel. Propag. Lett.*, Vol. 8, 1123-1126, 2009.
5. Sun, M., Y. P. Zhang, and Y. Lu, "Miniaturization of planar monopole antenna for ultra-wideband radios," *IEEE Trans. Antennas Propag.*, Vol. 58, No. 7, 2420-242, 2010.
6. Lee, W.-S., D.-Z. Kim, K.-J. Kim, and J.-W. Yu, "Wideband planar monopole antennas with dual band-notched characteristics," *IEEE Trans. Microwave Theory Tech.*, Vol. 54, 2800-2806, 2006.

7. Chung, K., J. Kim, and J. Choi, "Wideband microstrip-fed monopole antenna having frequency band-notch function," *IEEE Microwave Wireless Compon. Lett.*, Vol. 15, 766–768, 2005.
8. Kim, Y. and D. H. Kwon, "CPW-fed planar ultra wideband antenna having a frequency band notch functions," *Electron. Lett.*, Vol. 40, 403–405, 2004.
9. Yin, K. and J. P. Xu, "Compact ultra-wideband antenna with dual bandstop characteristic," *Electron. Lett.*, Vol. 44, 453–454, 2008.
10. Bi, D.-H., Z.-Y. Yu, S.-G. Mo, and X.-C. Yin, "Two new ultra-wideband antennas with 3.4/5.5 GHz dual band-notched characteristics," *Microwave Opt. Tech. Nol. Lett.*, Vol. 51, 2942–2945, 2009.
11. Ding, J., Z. Lin, Z. Ying, and S. He, "A compact ultra-wideband slot antenna with multiple notch frequency bands," *Microwave Opt. Tech. Nol. Lett.*, Vol. 49, 3056–3060, 2007.
12. Azim, R., M. T. Islam, J. S. Mandeep, and A. T. Mobashsher, "A planar circular ring ultra-wideband antenna with dual band-notched characteristics," *Journal of Electromagnetic Waves and Applications*, Vol. 26, Nos. 14–15, 2022–2032, 2012.
13. Azim, R., M. T. Islam, and A. T. Mobashsher, "Dual band-notch UWB antenna with single tri-arm resonator," *IEEE Antennas Wirel. Propag. Lett.*, Vol. 13, 670–673, 2014.
14. Dong, Y. D., W. Hong, J. Y. Zhou, and Z. Q. Kuai, "Design and implementation of planar ultra-wideband antennas characterized by multiple notched bands," *Microwave Opt. Tech. Nol. Lett.*, Vol. 51, 520–525, 2009.