

DESIGN OF WIRELESS POWER TRANSFER SYSTEMS USING MAGNETIC RESONANCE COUPLING FOR IMPLANTABLE MEDICAL DEVICES

Farid Jolani*, Jeetkumar Mehta, Yiqiang Yu,
and Zhizhang (David) Chen

Department of Electrical and Computer Engineering, Dalhousie University, Halifax, Canada

Abstract—Efficient and compact wireless power transfer (WPT) systems are proposed and designed for recharging small implantable medical devices. They use the magnetic resonance coupling scheme to transfer power over a relatively large distance. The receiver resonator coil and the load loop are designed in correspondence to size restriction of implantable devices. The dimensions of the coils are optimized and effective values of the lumped capacitors are investigated and fine-tuned for efficiency enhancement. Three design configurations of the WPT system, each consisting of two coils at the transmitter and two coils at the receiver, are designed and fabricated. The transfer efficiency is measured over different transmission distances and with different orientation angles of the receiver coils. The measurement results show good agreements with the simulations and illustrate that the proposed WPT systems exhibit nearly omnidirectional radiation performance. Furthermore, the receiver coils are implanted inside of a biological object to show the power can be transferred effectively.

1. INTRODUCTION

More and more efforts have been devoted to the research and development of wireless power transfer (WPT) technologies due to the increasing demands for truly wireless devices and green energy systems. One of the WPT enabling technologies is the magnetic resonance coupling. Since first reported in [1], it has been mostly used for mid-range transmission distance due to its simplicity in system design. One of its promising applications is for charging implantable medical devices

Received 5 February 2013, Accepted 25 March 2013, Scheduled 26 May 2013

* Corresponding author: Farid Jolani (farid.jolani@dal.ca).

(IMD) [2–4]. Currently, most commercial IMDs in the markets for examples, cardiac pacemakers, cardiac defibrillators and deep brain stimulators, utilize high-volume non-rechargeable batteries as power supply; they inevitably require surgeries to replace the batteries at the end of their life. In addition, bulky geometry and size of the batteries due to high energy capacity requirement becomes an obstacle in design of compact or micro IMDs. One of the methods proposed to overcome the problem is to charge IMDs wirelessly using inductive coupling technique [5]; however, the inductive coupling technique can only cover a very limited transmission distance with low transfer efficiency.

In 2006, the first set of magnetically coupled resonators was presented and named ‘WiTricity’ [1]. It consists of four coils, two on the transmitter side and two on the receiver side. When the system is properly designed, electromagnetic energy is inductively coupled from a driver loop to the transmitter resonant coils that creates a magnetic resonance coupled then to the receiver resonant coils; the energy or power is delivered from the transmitter to the load at the receiver load loop. It has been shown that using two identical resonators to operate in the strongly coupled regime can be very efficient; however, due to small size of implantable devices, both the receiver coils and the transmitter coils have to be small; as a result, if such a design is applied, the power transfer distance will be very limited. Thus in order to improve the power transfer range, the transmitter coils have to be big enough to increase the inductance of the coils on the transmitter side and improve the Q-factor of the whole system.

In this paper, with the magnetic resonance coupling scheme, three WPT systems with different coil dimensions and lumped elements are designed; both simulation and measurement results are discussed and analyzed to derive the final design that is suitable for wireless power transfer in small medical implantable devices. Furthermore, matching circuits are removed, which greatly reduces the design complexity and the size of the receiver. The receiver of the proposed WPT system is implanted in a 4 cm thick slab of pork meat to demonstrate the effectiveness of the wireless energy transfer from the drive loop to the load loop.

2. SCHEMATIC OF THE PROPOSED WIRELESS POWER TRANSFER SYSTEM AND EQUIVALENT CIRCUIT MODEL

As shown in Figure 1(a), the proposed wireless power transfer (WPT) system utilizes the magnetic resonant coupling. The key elements of designing such a system are the compensation capacitors that are used

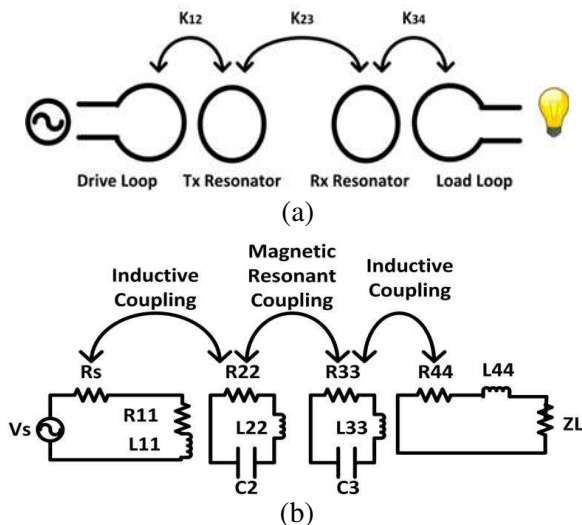

Figure 1. (a) Schematic of the wireless power transfer system using the magnetic coupling technique. (b) Equivalent circuit of the system.

to achieve resonant coupling between the large transmitter resonator coils and the small receiver resonator coils.

As shown in Figure 1(b), the system consists of four coils and can be modeled as a lumped RLC network using equivalent circuit theory. Theoretically, all four coils are coupled with each other, but the cross couplings are very weak and thus can be neglected. In the equivalent RLC circuit, the self-inductance of a loop is calculated as in [6]:

$$L = \mu_0 a \left(\ln \left(\frac{8a}{r} \right) - 2 \right) \tag{1}$$

where μ_0 is the space permeability, a is the radius of the loop and r is the radius of the wire.

For perfectly aligned coils, the mutual inductance of two parallel single-turn coils can be calculated as

$$M(r_1, r_2, \rho = 0, d) = \mu_0 \sqrt{r_1 r_2} \left[\left(\frac{2}{k} - k \right) K(k) - \frac{2}{k} E(k) \right] \tag{2}$$

where

$$k = \left(\frac{4r_1 r_2}{(r_1 + r_2)^2 + d^2} \right)^{1/2} \tag{3}$$

and $K(k)$ and $E(k)$ are the complete elliptical integrals of the first and second kind, respectively [6].

Considering the skin effect, the loss resistance of a loop is

$$R_L = \frac{\pi a}{r} \left(\frac{f \mu_0}{\pi \sigma} \right) \quad (4)$$

where σ is the conductivity of the wire and f is the operating frequency.

To achieve identical resonant frequencies for the transmitter and receiver coils, the lumped capacitors (C_{Tx} , C_{Rx}) shown in Figure 2 are calculated as follows:

$$C_i = \frac{1}{(2\pi f)^2 L_i} \quad (5)$$

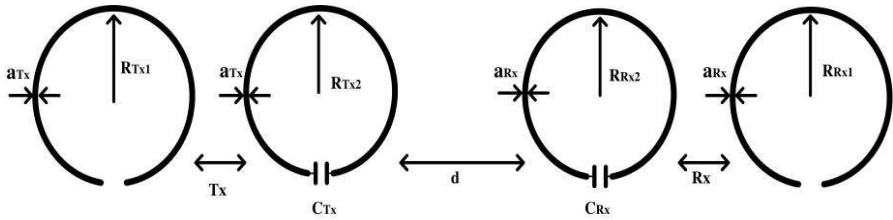

Figure 2. The proposed WPT system using magnetic resonance coupling.

The imaginary part of the equivalent impedance of a WPT system using magnetic resonance coupling can be assumed to be zero while it operates in resonance. Therefore, the power transfer efficiency can be calculated as

$$\eta = \frac{\text{Output Power}}{\text{Input Power}} = |S_{21}|^2 \quad (6)$$

3. DESIGN, SIMULATION AND MEASUREMENT RESULTS

Most implantable medical devices has size limitations, for instance, a typical pacemaker has a size of $44 \times 59 \times 7.9 \text{ mm}^3$; hence, in order to realize a practical wireless charging system for IMD, both the receiver resonator coil and the load loop should be small, and the wireless power should be transferred efficiently from the transmitter coils to the small receiver coils with reasonable transfer distances. To improve the transfer efficiency, [7] suggests the application of multi-turn coils for the receiver, whereas [8] uses the rectangular shaped receiver coil with a size of $10 \text{ cm} \times 5 \text{ cm}$. However, those designs are still too large to be applied to IMDs.

To derive a highly efficient and IMD-oriented WPT system with a size suitable for IMDs, we propose and investigated three designs. As shown in Figure 2, each of the proposed designs consists of four single-turn loops and no matching circuits are required. The geometric sizes and design parameters for each set of WPT system are listed in Table 1. All systems were designed to be operating at around 18.5 MHz. The designs were first simulated and analyzed with the High Frequency Structural Simulator (HFSS), and then fabricated. Due to intrinsic tolerance of the lumped capacitors, fine-tuning of the capacitors was performed to achieve the optimum transfer efficiency.

Table 1. Parameters of coils for the three designs.

	Design #1	Design #2	Design #3
R_{Tx1} (mm)	150	50	50
R_{Tx2} (mm)	200	50	50
R_{Rx1} (mm)	50	50	25
R_{Rx2} (mm)	50	50	25
a_{Tx} (mm)	12.7	2.8	2.8
a_{Rx} (mm)	2.8	2.8	0.785
T_x (mm)	180	36	36
R_x (mm)	3.25	3.25	3.25
d (mm)	100	100	100
C_{Tx} (pF)	100	360	360
C_{Rx} (pF)	330	360	652

Figure 3 shows the simulated and measured power transfer efficiency of design #1 with different distances d between the transmitter coils and the receiver coils. It is shown that the measured transfer efficiency are about 88%, 82%, 63%, 39% and 25% at the distance of 5 cm, 10 cm, 15 cm, 20 cm and 25 cm, respectively.

It is shown in [8] that the magnetic coupling between coils can be enhanced by making identical the transmitter and receiver coil sets. Such a strategy was applied to the second design, where the dimensions of the transmitter coils are made to the same of the receiver coils in the second design; all four coils now have a radius of 5 cm. As shown in Figure 4, the measured efficiency at the distance of 10 cm, 15 cm, and 20 cm are about 73%, 24%, and 6% respectively. The capacitances of C_{Tx} and C_{Rx} are 360 pF and 360 pF, respectively.

To develop an IMD-oriented WPT system, the third design was carried out with further reduction of the dimensions of the receiver

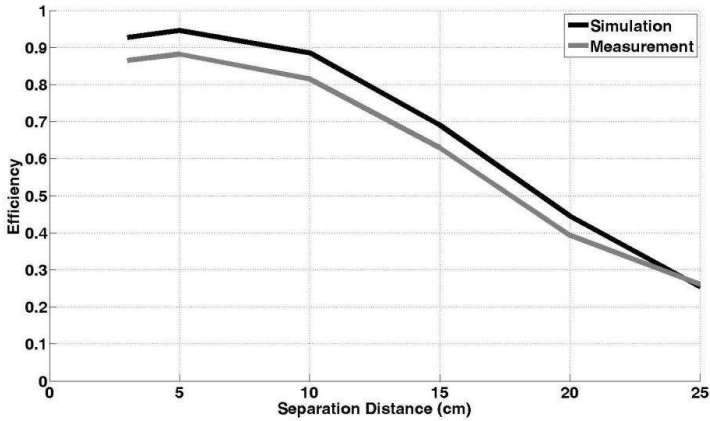

Figure 3. Simulated and measured transfer efficiencies of design #1 at different distances of d .

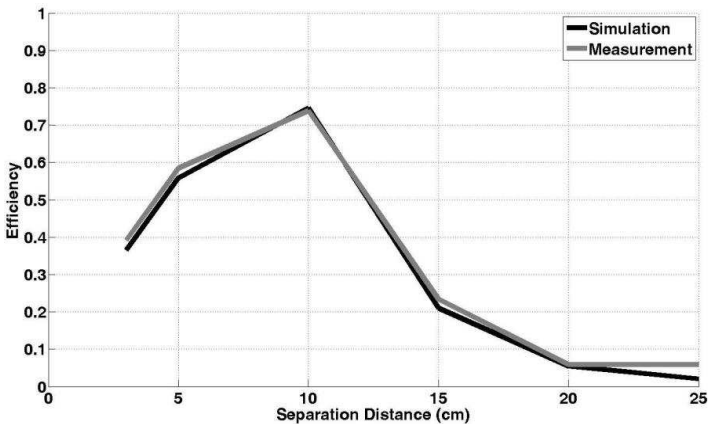

Figure 4. Simulated and measured transfer efficiency of design #2 at different distances.

coils. In it, the radius of the resonator coil and the load coil at the receiver side is reduced to 2.5 cm, which is comparable to the cross-sectional dimension of a commercial pacemaker; the compensation capacitors C_{Tx} and C_{Rx} are selected to be 360 pF and 652 pF, respectively. Figure 5 plots the S_{21} parameters of design #3 at a transfer distance of 10 cm, where the results computed from equivalent circuit model are included for comparison. The RLC values of the design are calculated with Equations (1)–(5) and deployed in the

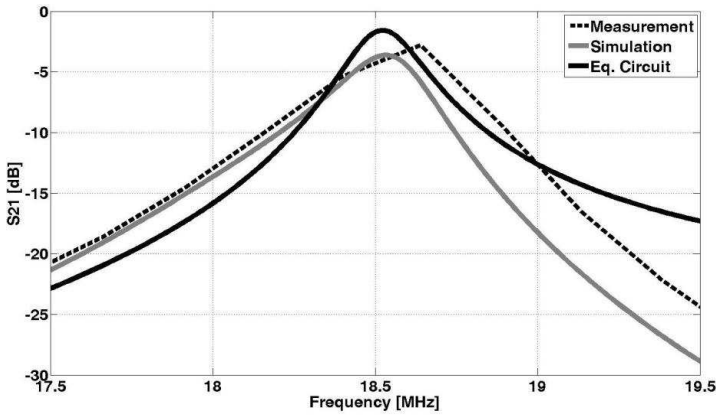

Figure 5. S_{21} of design #3 at a transfer distance of 10 cm.

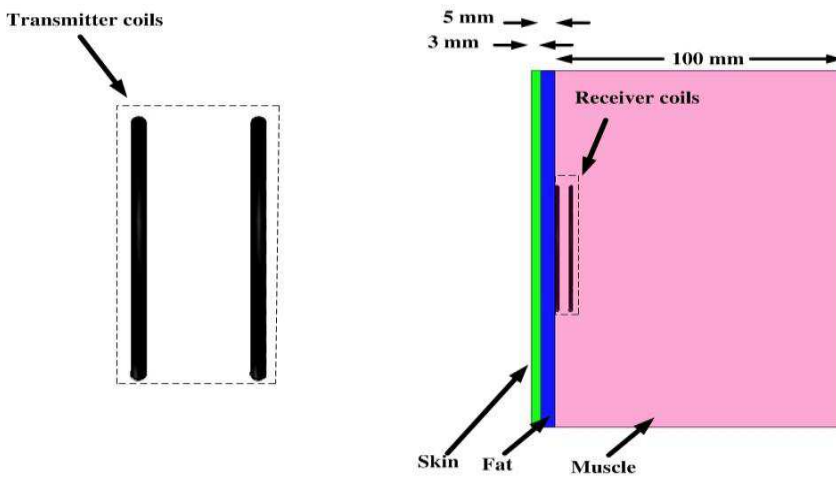

Figure 6. Simulation setup for design #3 with the receiver placed inside a stratified medium consisting of skin, fat and muscle layers.

equivalent circuit model for the analysis of scattering parameters and transfer efficiency.

The overall performance of the design #3 when it is implanted into tissues is also investigated. Figure 6 shows the configuration of the simulation setup, where the receiver coil set is embedded inside a stratified medium consisting of skin, fat and muscle layers of different thickness, and placed 10 cm away from transmitter coil set.

Table 2 shows the thickness, mass density and electrical properties

of different human tissues layers that are used in the full-wave simulation to evaluate the power transfer efficiency of design #3.

Table 2. Physical parameters and electrical properties of the stratified medium at 18.5 MHz.

Tissue	Relative electric permittivity (ϵ_r)	Conductivity (S/m)	Thickness (mm)	Mass Density (10^3 kg/m^3)
Skin	222.61	0.279	3	1.1
Fat	10.275	0.031	5	0.92
Muscle	115.28	0.639	100	1.04

Figure 7 shows the power transfer efficiency of design #3 at a transmission distance of 10 cm, before and after the receiver was placed into human tissues. As clearly seen, the transfer efficiency of the design reaches to 53% when it operates in the air and still retains higher than 43% after the implantation.

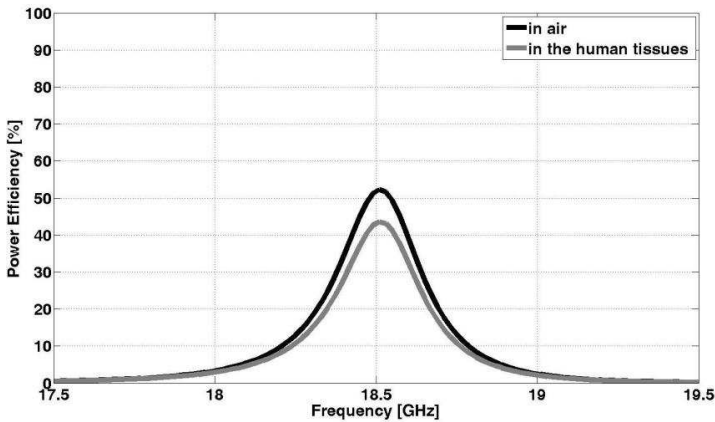

Figure 7. Simulated power efficiency of design #3 at a transfer distance of 10 cm before and after the implantation.

Figure 8(a) shows the fabricated third design. To imitate the practical situation, the receiver coils were placed inside a piece of pork meat and tested (see Figure 8(b)). A LED light was used as the receiver load and it was placed out of the meat skin to be visible. As shown

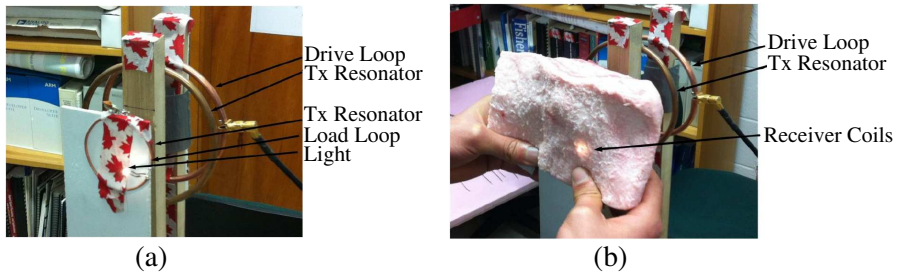

Figure 8. (a) The fabricated design #3. (b) The receiver coils are inserted into a 4-cm thick port meat and the transfer distance is 10 cm.

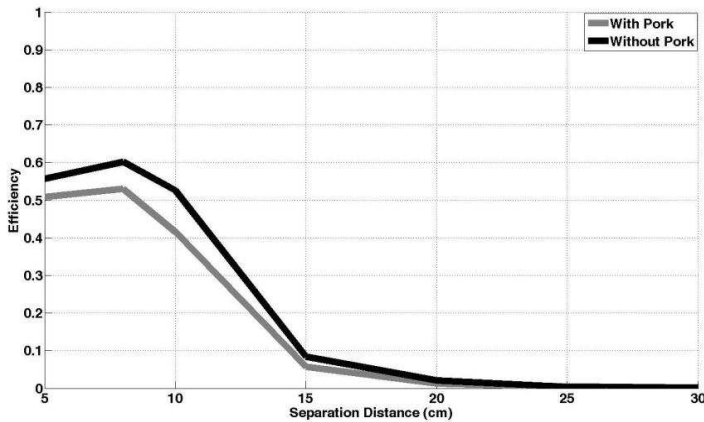

Figure 9. Measured power efficiency of design #3 at different distances of d .

in Figure 9, the measured transfer efficiency at the distance of 8 cm, 10 cm, and 15 cm are about 61%, 53%, and 8% respectively; and there is only small decrease in transfer efficiency when the receiver coils were implanted in the pork meat. Next, the performance of the third design with the receiver coils moving around the transmitter coils was also measured.

Figure 10 shows the transfer efficiency at a distance of 8 cm with varying orientation offset angles between the receiver coils and transmitter coils. As clearly seen, the power efficiency retains to be higher than 56% even when the receiver coils is moved up to 60 degrees off the axis of the coils on the transmitter sides. This indicates the nearly omnidirectional performance of the proposed WPT system.

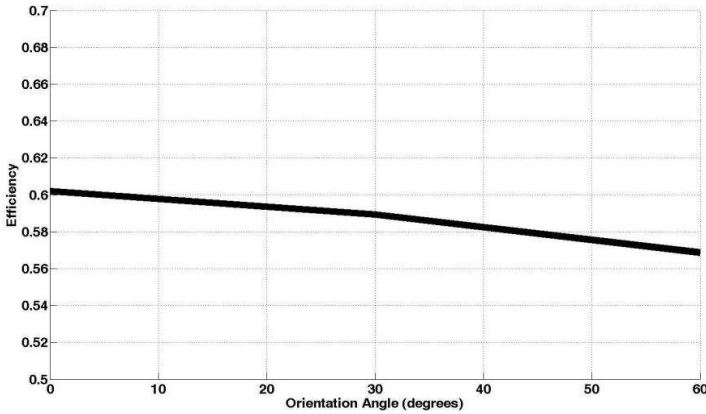

Figure 10. Measured power efficiency of design #3 with different orientation angles of receiver coils at the transfer distance of 8 cm.

4. CONCLUSION

In this paper, three wireless power transfer designs using magnetic resonance coupling are studied with different sizes of transmitter and receiver coils. With the radius of receiver coils reduced to 2.5 cm while the transfer efficiency retains higher than 50% in a relatively large transfer distance range, the proposed system can be applied to small implantable medical devices, such as pacemakers. Experimental results with the biological objects validated the effectiveness of proposed wireless power transfer system when implanted. Future work will include improvement of the transfer efficiency, investigation of the specific absorption rate (SAR) in the human body, and implementation of proposed designs to practical IMDs such as pacemakers.

ACKNOWLEDGMENT

The work was supported in part by the National Natural Science Foundation of China (NSFC) fund under contract 61061003 and Natural Science and Engineering Research Council of Canada under contract 155230-07.

REFERENCES

1. Kurs, A., A. Karalis, J. D. Moffatt, J. D. Joannopoulos, P. Fisher, and M. Soljacic, "Efficient wireless non-radiative mid-range energy

- transfer,” *Annals of Physics*, Vol. 323, 34–38, Jan. 2008.
2. Liu, X., F. Zhang, S. A. Hackworth, R. J. Scwabassi, and S. Mingui, “Modeling and simulation of a thin film power transfer cell for medical devices and implants,” *IEEE International Symposium on Circuits and Systems*, 3086–3089, May 2009.
 3. Li, X., H. Zhang, F. Peng, Y. Li, T. Yang, B. Wang, and D. Fang, “A wireless magnetic resonance energy transfer system for micro implantable medical sensors,” *Sensors 2012*, Vol. 12, No. 8, 10292–10308, Jul. 2012.
 4. Zhang, F., J. Liu, Z. Mao, and M. Sun, “Mid-range wireless power transfer and its application to body sensor networks,” *Open Journal of Applied Sciences*, Vol. 2, No. 1, 35–46, Mar. 2012.
 5. Schuder, J. C., “Powering and artificial heart: Birth of the inductively coupled-radio frequency system in 1960,” *Proc. Int. Center Artificial Organs*, Vol. 26, 2080–2083, Nov. 2002.
 6. Zierhofer, C. and E. Hochmair, “Geometric approach for coupling enhancement of magnetically coupled coils,” *IEEE Transactions on Biomedical Engineering*, Vol. 43, No. 7, 708–714, Jul. 1996.
 7. Cannon, B. L., J. F. Hoburg, D. D. Stancil, and S. C. Goldstein, “Magnetic resonant coupling as a potential means for wireless power transfer to multiple small receivers,” *IEEE Transactions on Power Electronics*, Vol. 24, No. 7, 1819–1825, Jul. 2009.
 8. Choi, J. and C. Seo, “Analysis on transmission efficiency of wireless energy transmission resonator based on magnetic resonance,” *Progress In Electromagnetics Research M*, Vol. 19, 221–237, 2011.