

A COMPACT DUAL-BAND PLANAR BRANCH-LINE COUPLER

D. C. Ji^{*}, B. Wu, X. Y. Ma, and J. Z. Chen

¹National Key Laboratory of Antennas and Microwave Technology, Xidian University, Xi'an 710071, P. R. China

Abstract—A novel branch-line coupler which can operate at two frequencies is presented in this paper. The proposed planar topology, which is different from the conventional one, is analyzed and designed. The new coupler maintains not only compact but also dual-band characteristics. The length of the proposed stepped-impedance lines can be adjusted flexible according to the required operation frequency. In order to verify the method, a dual-band micro-strip coupler operating at 0.9 and 2.1 GHz is fabricated and measured. The simulated and measured results show good agreements.

1. INTRODUCTION

To meet the increasing development of wireless communication, many modern communication systems have been developed and widely used in people's daily life, such as GSM (800/900/1800 MHz), WCDMA (2.1 GHz), WLAN (2.45/5.25 GHz) and Wimax (3.5 GHz). Meanwhile, when people design a passive device, other new additional requirements was put forward to adapt the complicated communication system, such as compact size, broad-band, and multiple-band operation mode [1] etc. In the RF chain, branch-line couplers [2], that always provide equal amplitude and quadrature phase outputs within the designed operating frequency band, have attracted more and more interests, especially for those ones which can operate at dual band frequency and occupy smaller circuit size simultaneously.

Many different methods for designing dual-band couplers have been explored and reported. Arbitrary dual-band microstrip components using composite right/left-handed (CRLH) transmission lines (TLs) were presented in [3]. A dual-band response achieved

Received 9 July 2012, Accepted 9 August 2012, Scheduled 10 August 2012

* Corresponding author: Decheng Ji (yyjdc@126.com).

by adding cross coupling branches to the conventional branch hybrid couplers was depicted in [4]. In [5], folded open stubs were attached to each stepped-impedance section at both its ends for the dual-band purpose. Moreover, rectangular patch hybrid coupler that can operate at two arbitrary frequency bands was reported in [6]. Stepped-impedance stubs to branches were also used to design the branch-line coupler with dual-band response [7, 8]. Meanwhile, a new branch-line coupler structure with port extensions was proposed for the dual-band operation in [9]. Another method using coupled transmission lines was demonstrated in [10, 11]. Furthermore, half wavelength sections had been considered in [12]. Besides, there are also some other approaches to meet the additional requirements such as compact size and dual-band [13–15].

In this paper, a compact planar dual-band branch-line coupler, which operates at 900 MHz GSM band and 2.1 GHz WCDMA band, is designed and implemented. According to transmission theory, the specific dimensions of the equivalent structure [16] are discussed in the first part. Then the actually equivalent transmission line structure known as the stepped impedance structure was discussed and determined. Finally, a compact dual-band branch-line coupler is optimally designed, fabricated and measured. The measured results agreed well with the simulation.

2. DESIGN OF COMPACT DUAL-BAND BRANCH-LINE COUPLER

The geometric graph of the proposed branch-line coupler is shown in Fig. 1. As seen from Fig. 1, the coupler is composed of two parts. There are four quarter-wavelength lines which compose the basic structure of

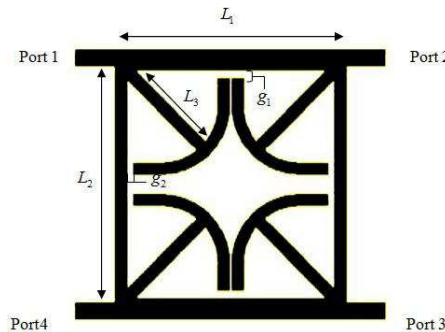

Figure 1. Geometric structure of the proposed dual-band coupler.

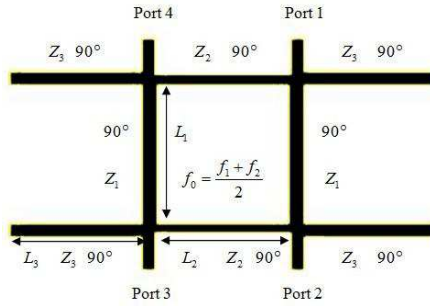

Figure 2. The coupler with open-circuit stubs.

the original coupler. The length is evaluated at the mid-frequency of the two operating bands. The other parts are four identical stepped-impedance transmission lines locating in the corners of the coupler separately. In the coming sections, the coupler will be designed and analyzed by three steps.

2.1. Design of the Original Branch-line Coupler

According to transmission line theory, the equivalent structure of quarter-wavelength branch line is discussed in [16]. A novel structure of branch-line coupler with open-circuit stubs and short-circuit stubs was proposed. The branch-line coupler which utilized open-circuit stub strategy to form two arbitrary operation frequency bands is shown in Fig. 2.

The original branch-line coupler that operates at 900 MHz and 2.1 GHz was designed according to the formulas [16].

$$\delta = \frac{f_2 - f_1}{f_2 + f_1} \tag{1}$$

$$Z_1 = \frac{Z_0}{\sqrt{2}} \cdot \frac{1}{\cos\left(\frac{\delta\pi}{2}\right)} \tag{2}$$

$$Z_2 = Z_0 \cdot \frac{1}{\cos\left(\frac{\delta\pi}{2}\right)} \tag{3}$$

$$Z_3 = \frac{Z_0}{1 + \sqrt{2}} \cdot \frac{1}{\sin\left(\frac{\delta\pi}{2}\right) \tan\left(\frac{\delta\pi}{2}\right)} \tag{4}$$

In this paper, the substrate with relative dielectric constant of 2.65 and height of 1 mm is used. In that case, the geometric parameters

Table 1. The geometric parameters of the branch-line coupler.

| Mid-frequency 1.5 GHz | | | |
|-----------------------|------------------------|-------------|------------|
| | Impedance (Ω) | Length (mm) | Width (mm) |
| Z_0 | 50 | 33.6 | 2.8 |
| Z_1 | 43.7 | 33.4 | 3.4 |
| Z_2 | 61.8 | 34 | 2 |
| Z_3 | 48.5 | 33.6 | 2.9 |

of the branch-line coupler which can be calculated and revised by using (5) to (10) [17], are listed in Table 1.

$$\text{For } W/h \leq 2, \frac{W}{h} = \frac{8 \exp(A)}{\exp(2A) - 2},$$

with

$$A = \frac{Z_c}{60} \left\{ \frac{\varepsilon_r + 1}{2} \right\}^{0.5} + \frac{\varepsilon_r - 1}{\varepsilon_r + 1} \left\{ 0.23 + \frac{0.11}{\varepsilon_r} \right\} \quad (5)$$

And for

$$W/h \geq 2, \frac{W}{h} = \frac{2}{\pi} \left\{ (B-1) - \ln(2B-1) + \frac{\varepsilon_r - 1}{2\varepsilon_r} \left[\ln(B-1) + 0.39 - \frac{0.61}{\varepsilon_r} \right] \right\},$$

with

$$B = \frac{60\pi^2}{Z_c \sqrt{\varepsilon_r}} \quad (6)$$

$$\varepsilon_{re} = \frac{\varepsilon_r + 1}{2} + \frac{\varepsilon_r - 1}{2} \left(1 + \frac{10}{u} \right)^{-ab} \quad (7)$$

where $u = W/h$, and

$$a = 1 + \frac{1}{49} \ln \left(\frac{u^4 + \left(\frac{u}{52}\right)^2}{u^4 + 0.432} \right) + \frac{1}{18.7} \ln \left[1 + \left(\frac{u}{18.1} \right)^3 \right] \quad (8)$$

$$b = 0.564 \left(\frac{\varepsilon_r - 0.9}{\varepsilon_r + 3} \right)^{0.053} \quad (9)$$

$$\lambda_g = \frac{300}{f(\text{GHz})\sqrt{\varepsilon_{re}}} \text{ mm.} \quad (10)$$

Taking the discontinuity into account, the length of the open-stubs is optimized as $L_3=34.6$ mm. Meanwhile, the gaps between arcs and main lines (marked as L_1 and L_2) are optimized as $g_1=1.13$ mm and $g_2=1.06$ mm.

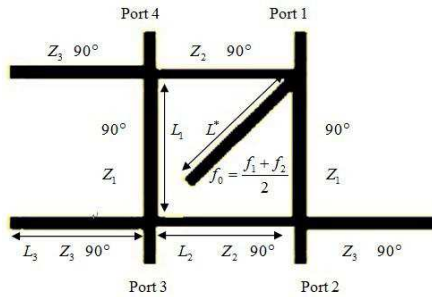

Figure 3. Coupler with one stub folded inward to the enclosed area.

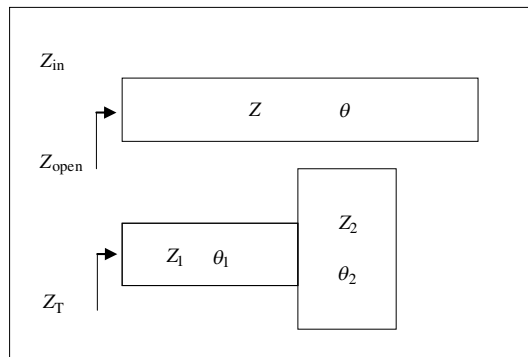

Figure 4. The definition of the following parameters.

2.2. Design of the Stepped Impedance Structure

As shown in Fig. 2, although the original branch-line structure possesses the dual-band characteristic, the four stubs take up a lot of space. Therefore, it may be a good idea that all the four stubs are folded inward to the enclosed area of the branch line. However, on one hand, keeping them straight will cause partial overlap which is obviously shown in Fig. 3 ($L^* = 37$ mm). In addition, put them folded will cause extra coupling which will degrade the performance. Hence, the novel stepped impedance structure shown in Fig. 5 is applied in the coupler.

According to the following input impedance formulas:

$$Z_{in} = Z_1 \frac{Z_l + jZ_1 \tan \theta}{Z_1 + jZ_l \tan \theta} \quad (11)$$

$$Z_{open} = -jZ \cot \theta \quad (12)$$

$$\begin{aligned}
 Z_T &= Z_1 \frac{-jZ_2 \cot \theta_2 + jZ_1 \tan \theta_1}{Z_1 + j(-jZ_2 \cot \theta_2) \tan \theta_1} \\
 &= Z_1 \frac{j(Z_1 \tan \theta_1 - Z_2 \cot \theta_2)}{Z_1 + Z_2 \tan \theta_1 \cot \theta_2}
 \end{aligned} \tag{13}$$

The parameters are defined in Fig. 4. For a quarter-wavelength transmission line, $Z_{\text{open}} = Z_T = 0$ should be satisfied.

That is

$$Z_1 \tan \theta_1 = Z_2 \cot \theta_2. \tag{14}$$

If Z_2 , θ_2 and θ_1 are firstly selected, then Z_1 can be determined. In this paper, $Z_2 = 15.09 \Omega$, $\theta_2 = 5.66^\circ$, $\theta_1 = 40^\circ$ have been chosen by taking into account the realizable impedance and the actually available internal enclosed area.

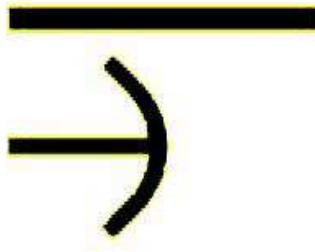

Figure 5. The comparison of the two structures.

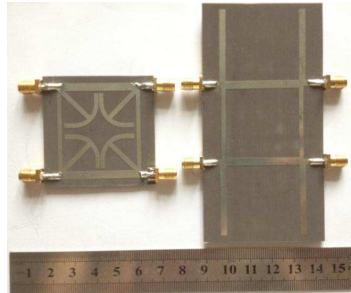

Figure 6. Photograph of the fabricated coupler.

2.3. Design of Dual-band Coupler

In order to make more effective use of the inner space, while not overlapped, the final geometric configuration of the stepped impedance structure is shown in Fig. 5.

Based on the analysis above, the dual-band characteristic is mainly determined by the equivalent structure of the traditional transmission line [16]. In order to get closer to the performance of the original structure, the low and high impedance structure is optimized through simulation. At last, the parameters are determined as $L_1=33.4$ mm, $L_2=37.7$ mm, $L_3=16.9$ mm, $L_4=24.7$ mm, $W_1=3.5$ mm, $W_2=2$ mm, $W_3=2.1$ mm, $W_4=2$ mm.

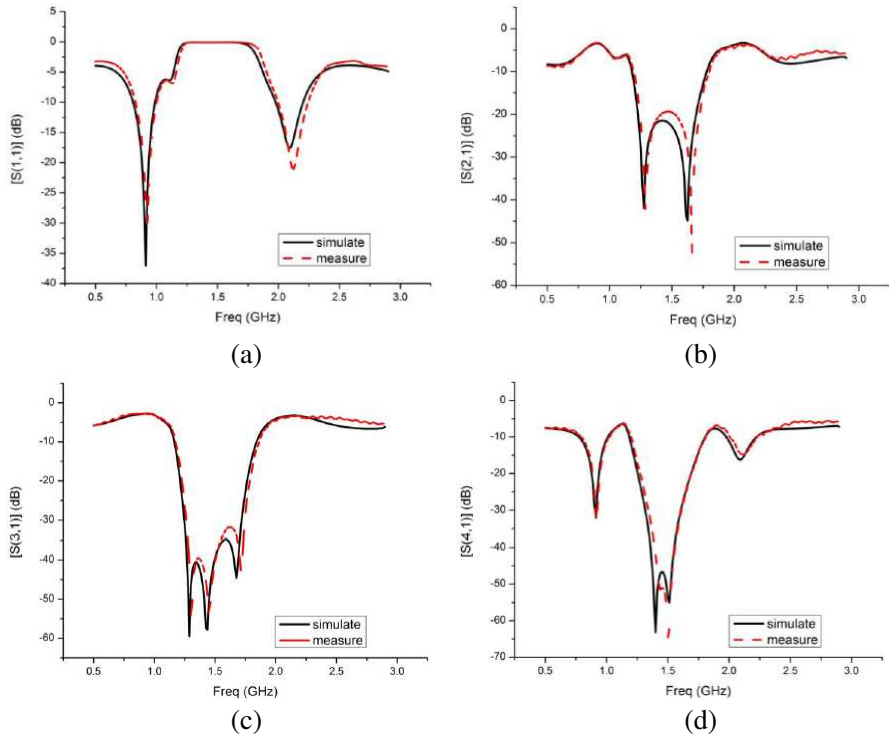

Figure 7. Measurement results of the fabricated dual-band coupler, (a) the return loss (S_{11}), (b) (c) the insertion loss (S_{21}) (S_{31}), (d) the isolation (S_{41}).

3. FABRICATION AND MEASUREMENTS

With the geometric dimensions listed above, a microstrip branch-line coupler is designed and fabricated on the substrate with relative dielectric of 2.65 and height of 1 mm. The total size of the coupler is $37.3\text{ mm} \times 43.2\text{ mm}$. The final pattern of the tested coupler is optimized by using the full-wave EM simulator IE3D. The fabricated coupler is measured by Agilent network analyzer 8719ES over the frequency range from 0.5 to 2.9 GHz. The manufactured couplers with their front view are shown in Fig. 6. The left one is the miniaturized coupler, while the right one is the coupler discussed in [16].

Figure 7 gives the measured responses of the coupler. The center frequencies of the two operating bands were found to be 910 and 2130 MHz. Seen from this figure, the measured results well agree with the simulated ones. Return loss and port isolation are better than -16 dB at the center frequencies of both operating bands. Furthermore, signal attenuation of over 20 dB was also observed around mid-frequency. In comparison to the ideal values, the measured insertion losses at the two output ports were 3.34 dB 3.20 dB at 910 MHz and 3.66 dB 3.33 dB at 2130 MHz. These discrepancies are mainly caused by the junction discontinuities and the dielectric loss as predicted in the simulation.

Figure 8 gives the phase response of the proposed coupler. Both the equal amplitude and quadrature phase conditions are closely matched (within 0.5 dB and 5°) over a wide bandwidth of almost 90 MHz.

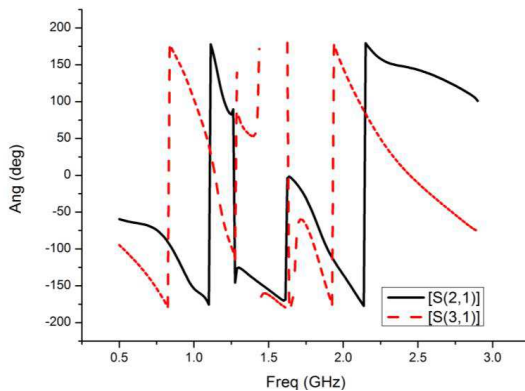

Figure 8. The phase response of the proposed coupler.

4. CONCLUSIONS

A novel compact dual-band coupler realized by locating four stepped impedance stubs inside its inner area is presented in this paper. The low and high impedance transmission line structure is adopted to minimize the branch-line coupler circuit size. A dual-band coupler operating at GSM and WCDMA band is designed and fabricated. The obtained frequency responses demonstrate that the coupler owns good dual-band property. Measurement results show that the new coupler works well at both of the assigned center frequencies.

ACKNOWLEDGMENT

This work is supported by the National Key Laboratory Foundation of Antennas and Microwave Technology.

REFERENCES

1. Zhang, H. L. and H. Xin, "Dual-band branch-line balun for millimeter wave applications," *IEEE Trans. Microw. Theory Tech.*, 717–720, Jun. 2009.
2. Pozar, D. M., *Microwave Engineering*, 2nd Edition, Wiley, New York, 1998.
3. Lin, I.-H., M. DeVincentis, C. Caloz, and T. Itoh, "Arbitrary dual-band components using composite right/left-handed transmission lines," *IEEE Trans. Microw. Theory Tech.*, Vol. 52, No. 4, 1142–1149, Apr. 2004.
4. Park, M.-J. and B. Lee, "Dual-band, cross coupled branch line coupler," *IEEE Microw. Wireless Compon. Lett.*, Vol. 15, No. 10, 655–657, Oct. 2005.
5. Hsu, C.-L. and J.-T. Kuo, "Design of dual-band branch line couplers with circuit miniaturization," *Asia Pacific Microwave Conference*, 16–20, Dec. 2008.
6. Zheng, S. Y. and S. H. Yeung, "Dual-band rectangular patch hybrid coupler," *IEEE Trans. Microw. Theory Tech.*, Vol. 56, No. 7, 1721–1728, Jul. 2004.
7. Chin, K.-S. and K.-M. Lin, "Compact dual-band branch-line and rat-race couplers with stepped-impedance-stub lines," *IEEE Trans. Microw. Theory Tech.*, Vol. 58, No. 5, 1213–1221, May 2010.
8. Zheng, N., L. Zhou, and W.-Y. Yin, "A novel dual-band II-shaped

- branch-line coupler with stepped-impedance stubs,” *Progress In Electromagnetics Research Letters*, Vol. 25, 11–20, 2011.
9. Kim, H. and B. Lee, “Dual-band branch-line coupler with port extensions,” *IEEE Trans. Microw. Theory Tech.*, Vol. 58, No. 3, 651–655, Mar. 2010.
 10. Yeung, L. K., “A compact dual-band 90 coupler with coupled-line sections,” *IEEE Trans. Microw. Theory Tech.*, Vol. 59, No. 9, 2227–2232, Sept. 2011.
 11. Atlasbaf, Z. and K. Forooghi, “A new dual band branch-line coupler using coupled lines,” *Antennas, Propagation & EM Theory*, 1–4, Oct. 2006.
 12. Wong, F. L. and K. K. M. Cheng, “A novel planar branch line coupler design for dual-band applications,” *IEEE Trans. Microw. Theory Tech.*, Vol. 2, 903–906, Jun. 2004.
 13. Monti, G. and L. Tarricone, “Dual-band artificial transmission lines branch-line coupler,” *International Journal of RF and Microwave Computer-Aided Engineering*, 2007.
 14. Keshavarz, R., M. Danaeian, M. Movahhedi, and A. Hakimi, “A compact dual-band branch-line coupler based on the interdigital transmission line,” *2011 19th Iranian Conference on Electrical Engineering (ICEE)*, 1–5, May 2011.
 15. Jizat, N. M., S. K. A. Rahim, T. A. Rahman, and M. R. Kamarudin, “Miniaturize size of dual band branch-line coupler by implementing reduced series arm of coupler with stub loaded,” *Microwave and Optical Technology Letters*, Vol. 53, No. 4, Apr. 2011.
 16. Cheng, K. K. M. and F. L. Wong, “A novel approach to the design and implementation of dual-band compact planar 90 branch line coupler,” *IEEE Trans. Microw. Theory Tech.*, Vol. 52, No. 11, 2458–2462, Nov. 2004.
 17. Hong, J.-S. and M. J. Lancaster, *Microstrip Filters for RF/Microwave Applications*, 2001.