

A HIGH-POWER LOW-LOSS MULTIPORT RADIAL WAVEGUIDE POWER DIVIDER

X.-Q. Li*, Q.-X. Liu, and J.-Q. Zhang

School of Physical Science and Technology, Southwest Jiaotong University, Chengdu 610031, China

Abstract—A 16-way radial waveguide power divider with the characteristics of low insertion loss and high power handling capacity is investigated. Its design theory and basic structure are proposed at first; a power divider with the center frequency of 4.0 GHz is designed, fabricated, and measured. Good agreement between the simulated and measured results is found for the proposed power divider. The measured 15-dB return loss bandwidth is demonstrated to be 440 MHz and the measured 0.5-dB insertion loss bandwidth is demonstrated to be 540 MHz. The power handling capacity of the proposed power divider is analyzed through simulation, and the results prove its usability in high power applications.

1. INTRODUCTION

Power dividers have been widely used in microwave and millimeter-wave systems. Different types of power dividers are needed for different application occasions. In the design of high-power microwave system and high-power radar transmitter system, the power dividers should satisfy several critical requirements, which include high power handling capacity, low insertion loss and usually multiport output. The typical power handling capacity needed reaches hundreds of MW or several GW [1, 2]. In this particular domain, conventional microstrip line and stripline power divider [3, 4] cannot be used due to their poor power handling capacity and waveguide power divider is much more suitable. However, in order to achieve the extremely high power handling capacity, several conditions should be satisfied, even for the waveguide power divider. First, there should not exist medium material in the power divider as it reduces the breakdown threshold

Received 10 January 2012, Accepted 17 April 2012, Scheduled 1 May 2012

* Corresponding author: Xiang-Qiang Li (xiangqiang.li@hotmail.com).

under vacuum condition. Second, the structure of the power divider must be well designed as to have no notable field concentration inside the power divider.

The radial waveguide is a special kind of waveguide, and it has an inherent high power handling capacity, low loss and compact structure. An effective way to achieve multiport output is using radial waveguide as feeding waveguide and coupling energy out in some certain way, as having been reported in [5, 6]. In [6], the E -coupled probes are used to couple energy. The E -coupled probe has a biggish field concentration at the end of the inner conductor, and the medium support must be used to fix the E -coupled probes. Also, this power divider adopts absorbing material to absorb the remaining energy at the edge of the radial waveguide. These aspects inevitably reduce its power handling capacity and increase its insertion losses.

To overcome this problem, the authors have studied a four-way radial waveguide power divider [7]. This paper is the continuation of this current research. A 16-way radial waveguide power divider is proposed and designed. Its main performances, including the power handling capacity, the insertion loss, the imbalance and isolation among output ports, are investigated.

2. DESIGN THEORY AND BASIC STRUCTURE

Figure 1 shows the basic structure of the proposed power divider with 16 output ports. The input port is a big coaxial waveguide and the output ports are small coaxial waveguides. The input

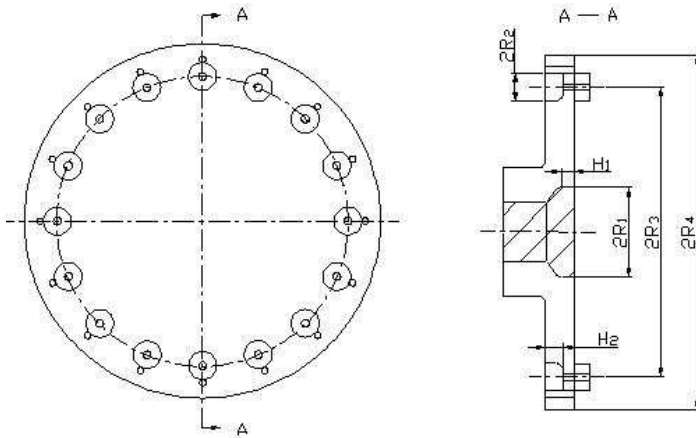

Figure 1. Basic structure of the proposed power divider.

transverse electromagnetic (TEM) coaxial mode is transitioned to an outgoing radial mode by a coaxial-radial waveguide junction. The inner conductor of each output port is connected with a probe inserted into the radial waveguide, and excited by the outgoing wave between the two parallel plates of the waveguide. All of the output ports are arranged at the same circle on the upper plate and the outer edge of the radial waveguide is also circular. 16-port equal-amplitude in-phase distribution can be therefore achieved by optimizing the mode converter, the probes and the radius of the radial line edge.

In this 16-way radial waveguide power divider, new kinds of coupling probe and coaxial-radial waveguide junction are used. They can both fix directly on the radial waveguide to avoid using the medium support, which can improve the power-handling capacity of the power divider. Metal material is used at the edge of the radial waveguide instead of the absorbing material. Hence, the whole structure is constituted entirely by metal materials, which reduces the insertion loss and increases the power-handling capacity.

3. DESIGN OF THE POWER DIVIDER

A radial waveguide power divider with the center frequency of 4.0 GHz is designed to verify the above design theory. The spacing of the two parallel plates should be sufficiently small when comparing with the wavelength to make only the TEM radial mode propagating in the radial waveguide. For this reason, the spacing is chosen to be $20\text{ mm} = 0.27\lambda$ (where $\lambda = 75\text{ mm}$ is the free-space wavelength at 4.0 GHz). The inner radius and outer radius of the input coaxial waveguide are 20 mm and 45 mm respectively. The inner radius and outer radius of the output coaxial waveguide are 2.5 mm and 9.5 mm respectively.

Coaxial-radial waveguide junction is the first part to be designed in the power divider. Different from conventional junctions [8, 9], the proposed structure can be joined with the upper plate of the radial waveguide, that avoids the use of medium support and the biggish field

Table 1. Optimization information of coaxial-radial waveguide junction.

Optimization parameters	R_1	20–40 mm
	H_1	0–20 mm
Concerned performances	S -parameter S_{11} (4.0 GHz, 3.8 GHz, 4.2 GHz)	
Run-time	2 minutes for each set of parameters	

concentration. The optimization of the junction is carried out by the software HFSS of Ansoft Company. Its optimization information can be summarized in Table 1. Calculations are carried out for each set of parameters using the parametric analysis function and the results are compared to select a favorable combination. High conversion efficiency from the TEM coaxial mode to the TEM radial mode is obtained with the optimized dimension.

The use of the new probe is a notable characteristic in the power divider. The configuration of the new probe is shown in Figure 2. This kind of probe consists of a cylindrical base and an L-shaped conductor, which are made entirely of metal materials. The cylindrical base has a radius of R_c and a height of H_c ; the L-shaped conductor has a rectangular section and a maximum distance of L to the probe axis. The cylindrical base and L-shaped conductor of the new probe can be used to fix the probe on the radial waveguide directly. Consequently, the use of the new probe avoids the appearance of a medium support, which greatly increases the power-handling capacity.

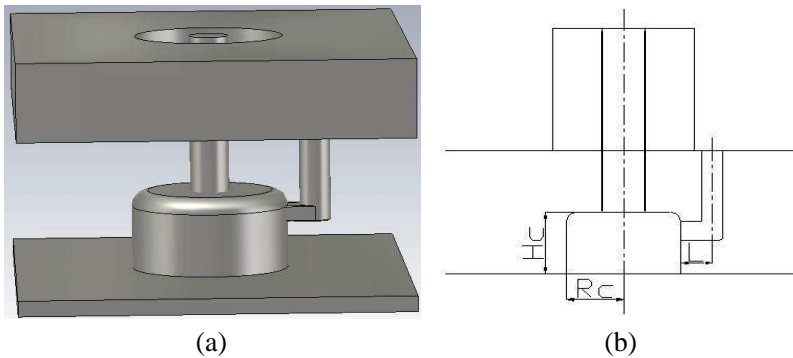

Figure 2. Configuration of the new probe.

Table 2. Coupling characteristic of the new probe.

R_c/mm	H_c/mm	L/mm	Coupled magnitude	Reflected magnitude
8.0	6.0	3.5	0.51	0.10
8.0	12.0	3.5	0.64	0.04
10.0	6.0	3.5	0.55	0.07
10.0	12.0	3.5	0.70	0.10

The coupling characteristics of the probe can be approximately analyzed by being placed in a rectangular waveguide with magnetic symmetric boundary [10]. The simulated results are summarized in Table 2. The result indicates that the new probe can adjust the coupled magnitude by setting the dimension of the probe properly, and keep the reflected magnitude at a lower level. The electric field distribution of the new probe is also analyzed, and compared with the E -coupled probes, as shown in Figure 3. When these two probes realize the same coupled magnitude (take 0.6 for example), their electric field distributions are shown in Figure 3. It can be seen that the new probe significantly reduce the maximum magnitude of the E -field (from 3191 V/m to 1525 V/m), which improve the power handling capacity at a certain extent. The new probe is therefore more suitable for energy coupling.

The power divider is then designed by optimizing the dimension of the probes to ensure an appropriate coupled coefficient and a low reflected coefficient. The radius of the edge of the power divider (R_4) is also optimized to finalize the power divider design. The optimizations are all carried out by HFSS and the optimization method is the same with optimizing the coaxial-radial waveguide junction. The optimized dimensions of the mode converter, probe and the radius of the power divider edge are listed in Table 3.

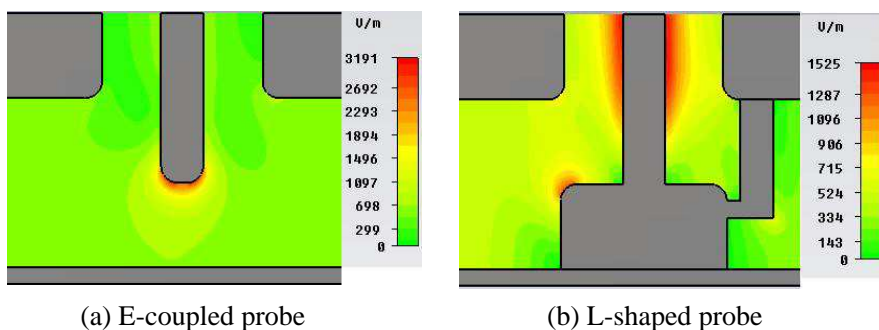

Figure 3. Electric field distribution of the probe.

Table 3. Dimensions of the structure (Unit: mm).

R_1	R_2	R_3	R_4	H_1	H_2
30.0	10.0	102.0	120.0	10.0	10.0

4. SIMULATED AND MEASURED RESULTS

The power divider is finalized and fabricated. Figure 4 shows a photograph of the power divider. It is simulated with the software HFSS. It is measured with a two-port vector network analyzer. As the input port and the output ports of the power divider are non-standard coaxial waveguides, impedance converters are needed to convert this port to the standard port, like N-type port. Two kinds of impedance converters are therefore designed and fabricated, which are connected to the input port and output port of the power divider respectively. Two-port measurements are taken between the input port and each output port to test the S -parameters of the power divider, while the remaining output ports were terminated using coaxial matched loads, as shown in Figure 4. It should be noted that these impedance converters show good performances, and will not influence the measured results of the power divider. The insertion loss of these impedance converters is approximately 0.1 dB. As they are not needed in practical applications, this insertion loss should be deducted in calculating the insertion loss of the power divider.

The measurement gives the amplitudes and phases of 16 output ports in the frequency range of 3.7–4.3 GHz. The measured amplitudes of S -parameters at 4.0 GHz are summarized in Table 4. With these



Figure 4. Photograph of the power divider under test.

Table 4. The measured amplitudes of S -parameters at 4.0 GHz.

Port	1	2	3	4	5	6	7	8
I	0.228	0.232	0.235	0.247	0.245	0.232	0.246	0.248
Port	9	10	11	12	13	14	15	16
I	0.254	0.243	0.236	0.253	0.251	0.245	0.233	0.232

results, the average transmission of the power divider can be calculated by the following formula:

$$TR_{av} = 10 \log \left[\left(\sum_{i=1}^{16} S_{i0}^2 \right) / 16 \right] + IL_{ic} \tag{1}$$

where TR_{av} is the average transmission, S_{i0} the amplitude for output port i , and IL_{ic} the insertion loss of the impedance converters. As the ideal transmission for a 16-way power divider is -12 dB, the average insertion loss of the power divider can be calculated using the following formula:

$$IL_{pd} = -12 - TR_{av} \tag{2}$$

The reflection and average transmission of the power divider are shown in Figure 5. It can be concluded that the measured average insertion loss of the power divider is 0.2 dB and the return loss is approximately -28.5 dB. The measured 15-dB return-loss bandwidth of the power divider is found to be 440 MHz. The measured 0.5-dB insertion loss bandwidth is found to be 540 MHz. Compared with the simulated results, the measured return loss and insertion loss are higher. These differences could be explained by the following factors. First, machining and assembling could change slightly the sizes of the power divider; second, the junctures in the experiment increases the insertion loss and the actual metallic material also has an ohmic loss, which does not exist in the simulation. Nevertheless, the measured results show a good agreement with the simulated ones.

It should be noted that the measured amplitude and phase at the output ports of the power divider is not exactly uniform. The amplitude and phase imbalances are shown in Figure 6 (where only three typical curves are given respectively, i.e., the minimum, the

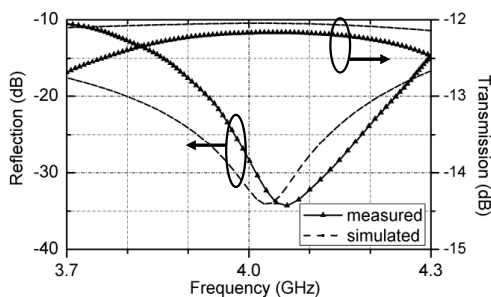

Figure 5. Simulated and measured results.

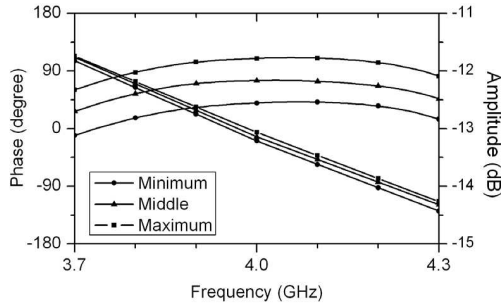

Figure 6. Amplitude and phase imbalances at the output ports.

middle and the maximum). In the range of 3.7–4.3 GHz, the output amplitude imbalance is about ± 0.4 dB, and the output phase imbalance is about $\pm 7^\circ$. These imbalances are most likely related to the symmetry errors of the power divider that include the fabrication errors among coupling probes and the differences among impedance converters. Also, the inevitable mismatch on the ports could cause additional imbalances.

In order to improve the insertion loss and to reduce the imbalances among output ports, several strategies are intended to adopt in later research. The most effective improvement is the optimization of the manufacture method. First, the probes should be made together with the lower plate of the radial waveguide. This approach can reduce the imbalances caused by probe assembling errors and avoid the insertion losses caused by tiny assembling gaps. Second, machining accuracy should be improved to ensure the consistency of the probes. Third, the inner surface of the power divider should be plated with higher conductivity metal to reduce the ohmic loss. Moreover, the power divider is expected to be further optimized to reduce its field concentration level.

The isolations among output ports are also analyzed. Take output port 1 for example, the simulated S -parameters S_{i1} are shown in Figure 7. The results displayed include S_{21} , S_{31} , ..., and S_{91} . $S_{16,1}$, $S_{15,1}$, ..., and $S_{10,1}$ are the same as S_{21} , S_{31} , ..., and $S_{8,1}$ respectively. It can be seen that the interaction between two opposite output ports is the strongest. The transmission passage between these ports may be optimized to improve the isolations.

As emphasized above, another important feature of the power divider is the high power handling capacity. To illuminate this point, the electric field distribution in the power divider is simulated and shown in Figure 8. It can be seen that the maximum electric field is

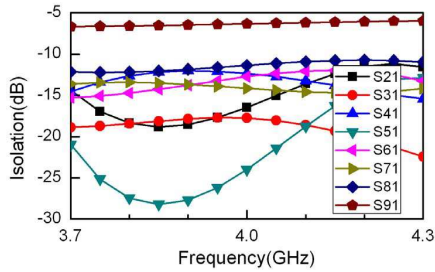

Figure 7. Isolation among output ports.

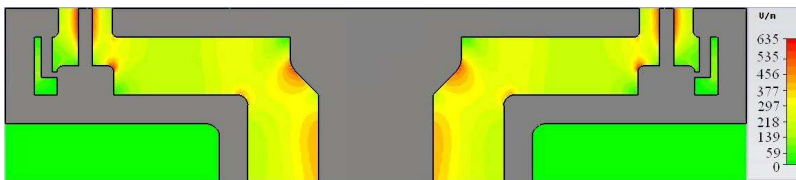

Figure 8. Electric field distribution in the power divider.

approximately 635 V/m when the input power is 0.5 W. If we maintain the vacuum state in the power divider, and assume the breakdown threshold to be 50 MV/m under vacuum condition [11], the power-handling capacity for this feed system could reach 3 GW, which is suitable for high power application.

5. CONCLUSION

In this letter, a novel multiport radial waveguide power divider is proposed and investigated. A 16-port power divider is designed, simulated and measured. The measurement results indicate that in the range of 3.7–4.3 GHz, this power divider can realize the approximate uniform in-phase division of input microwave. Numerical simulation also illustrate that the power divider has a high power handling capacity, which makes it suitable for high power application.

ACKNOWLEDGMENT

The authors would like to thank the Fundamental Research Funds for the Central Universities (SWJTU09ZT38, SWJTU11CX077) for their support in this research.

REFERENCES

1. Nantista, C. D. and S. G. Tantawi, "A compact, planar, eight-port waveguide power divider/combiner: The cross potent superhybrid," *IEEE Microw. Guided Wave Lett.*, Vol. 10, No. 12, 520–522, 2000.
2. Christopher, S., V. A. Abid Hussain, M. S. Easwaran, and V. N. Dabade, "Design aspects of compact high power multipoint unequal power dividers," *IEEE International Symposium on Phased Array Systems and Technology*, 15–18, Oct. 1996.
3. Wilkinson, E. J., "An n-way hybrid power divider," *IRE Trans. Microw. Theory Tech.*, Vol. 8, 116–118, Jan. 1960.
4. Lu, F. and K. Chang, "A 180° out-of-phase power divider using asymmetrical coplanar stripline," *IEEE Microw. Guided Wave Lett.*, Vol. 6, No. 11, 404–406, 1996.
5. Chang, K., M. Li, and K. A. Hummer, "High power four-way power divider/combiner," *IEEE MTT-S International Microwave Symposium Digest*, Vol. 3, 1329–1332, 1990.
6. Chen, S., "A radial waveguide power divider for Ka band phased array antennas," *3rd International Conference on Microwave and Millimeter Wave Technology Proceedings*, 948–951, 2002.
7. Zhang, J.-Q., Q.-X. Liu, X.-Q. Li, and L. Zhao, "Four-way radial waveguide power divider with high power-handling capacity," *The Journal of China Universities of Posts and Telecommunications*, Vol. 18, No. 5, 124–128, 2011.
8. Nakano, H., H. Takeda, and Y. Kitamura, "Low-profile helical array antenna fed from a radial waveguide," *IEEE Trans. on Antennas and Propagation*, Vol. 40, No. 3, 279–284, 1992.
9. Bialkowski, M. E. and P. W. Davis, "Analysis of a circular patch antenna radiating in a parallel-plate radial guide," *IEEE Trans. on Antennas and Propagation*, Vol. 50, No. 2, 180–187, 2002.
10. Song, K., Y. Fan, and Y. Zhang, "Eight-way substrate integrated waveguide power divider with low insertion loss," *IEEE Transactions on Microwave Theory and Techniques*, Vol. 56, No. 6, 1473–1477, 2008.
11. Miller R. B., W. F. McCullough, K. T. Lancaster, and C. A. Muehlenweg, "Super-reltron theory and experiments," *IEEE Trans. on Plasma Science*, Vol. 20, No. 3, 332–343, 1992.