

CRLH ZOR ANTENNA OF A CIRCULAR MICROSTRIP PATCH CAPACITIVELY COUPLED TO A CIRCULAR SHORTED RING

S. Yoo and S. Kahng*

Department of Information and Telecommunication Engineering,
University of Incheon, 12-1 Songdo-dong, Yeonsu-gu, Incheo 406-772,
Korea

Abstract—In this paper, a novel Metamaterial (MTM) CRLH Zeroth Order Resonance (ZOR) Circular microstrip patch antenna is proposed to have a monopole antenna pattern due to the completely closed loop of a magnetic current around the structure, and reduced profile and size due to the left-handedness. Different from other ZOR antennas of 1D periodic arrays with shorted patches, we suggest 1 circular patch capacitively coupled to 1 circular shorted ring to have ZOR and -1 st resonance modes. The antenna is designed and modeled with equivalent circuits for the coaxial-fed central patch and the circular shorted ring and verified by the comparison with 3D EM simulation of the physical structure. The no-phase variation at the ZOR (2.4 GHz) and the -1 st resonance mode (2 GHz) as the metamaterial properties are proven with electric field distributions and far-field patterns. The measurement shows there exist the ZOR and the -1 resonance modes despite the frequency shift from the simulation, which is proven by the monopolar radiation pattern and broadside radiation pattern, respectively. So the advantages of the proposed antenna will be addressed with the low-profile monopole at the ZOR and the size reduction effect at the -1 st resonance.

1. INTRODUCTION

Portable devices for wireless communication are required to have smaller RF components and antennas, while the high quality of their performances like multi-functions should be maintained. The researchers have sought and tried a number of approaches to

Received 28 July 2011, Accepted 28 September 2011, Scheduled 19 October 2011

* Corresponding author: Sungtek Kahng (s-kahng@incheon.ac.kr).

circumvent the conflicts between the requirements on the size and function.

One of the latest ways to tackle the problem is taking advantage of metamaterial (MTM) structures. The MTM is artificially formed and engineered, showing negative or near zero or zero effective permittivity ($\varepsilon_{\text{reff}}$) and permeability (μ_{reff}). On the contrary to the phase delay from the Right-Handed (RH) wave with Double Positive $\varepsilon_{\text{reff}}$ and μ_{reff} , (DPS), the Left-Handed (LH) wave with Double Negative $\varepsilon_{\text{reff}}$ and μ_{reff} , (DNG) results in phase-lead phenomenon. The difference between phase delay and phase lead in the Composite RH and LH (CRLH) determines the propagation number for Zeroth Order Resonance (ZOR), Negative resonance (NR), and Positive resonance (PR) of the structure. Specifically, the ZOR where no phase variation or infinite wavelength occurs and the Negative resonance are found helpful to the design of microwave components and antennas [1, 2].

Particularly, when the MTM is applied to antenna designs, CRLH-line cells are periodically arrayed to make leaky wave antennas or resonant ones [3–6]. ZOR CRLH antennas are brought up to obtain the benefit of size-reduction [2–6]. Lai et al. and Lee et al. place mushrooms periodically in a 1D array with a line-feeding and show the monopolar radiation pattern from a microstrip patch at the DNG ZOR [3–5]. Instead of the DNG type ZOR, Kim et al. make the Epsilon Negative (ENG) ZOR antenna in the form of 1D periodic mushrooms [6]. Gomez-Diaz et al. put shorted metal strips close together in a longitudinal line to create leaky-wave radiation from a fast-wave region of the dispersion characteristic [7]. Lee and Lee. made a 3X3 array of periodic mushrooms to enlarge magnetic current loop for increasing the antenna gain [8]. Neither periodic nor an array form, Jang et al. coupled a half-wavelength rectangular patch to a rectangular ring having a few vias to make ZOR radiation with increased antenna gain [9].

In this paper, we propose a new MTM antenna by transforming a circular patch of 2.4 GHz PR to the DNG-type ZOR antenna through capacitive coupling to 1 circular shorted ring. In other words, the positive half-wavelength resonance changes to the ZOR phenomenon at the same frequency. As a result, it comes to have the monopolar far-field pattern at the ZOR frequency and the broadside radiation pattern at the -1st resonance as the lower frequency as well. For design and analysis, we use the equivalent circuits of the conventional PR and the attached circular shorted ring for the CRLH DNG, and we implement this antenna with a dielectric substrate different from [9] which uses the air under the patch to avoid possible mechanical instability. It is validated by the 3D EM simulation,

the fabrication, and the measurement. Especially, the simulated and measured radiation patterns at the -1 st resonance and the ZOR will prove the metamaterial properties of the proposed non-periodic MTM antenna along with the no-phase variation E -field at the ZOR frequency over the entire geometry, in spite of the frequency deviation of the experiment from the predicted S_{11} . Finally, the antenna gain of about 2 dBi \sim 5 dBi is mentioned along with the size-reduction effect by the -1 st resonance mode and the ZOR in terms of the broadside antenna pattern and low profile monopolar pattern.

2. EQUIVALENT CIRCUITS OF THE CIRCULAR PATCH AND THE PROPOSED CRLH ZOR ANTENNA

To change the conventional half-wavelength Circular patch antenna to the CRLH form, it is necessary to know the equivalent circuits of the conventional patch antenna and the proposed circular shorted ring. When the patch resonates at 2.4 GHz with coaxial-feeding as in Fig. 1(a), it can be expressed with the equivalent circuit in Fig. 1(b) where L_1 , L_2 and C_1 are calculated 1 nH, 0.2 nH and 4.6 pF, respectively. L_1 and C_1 account for the series inductance of the patch surface and the shunt capacitance between the patch and the ground. L_2 mainly comes from the inner conductor of the coaxial feed. At the resonance mode, say, half-wavelength resonance ($\lambda g/2$) mode, the electric field is distributed as out-of-phase vectors at the opposite edges of the patch. This conventional antenna radiates fields in the broadside and in order to have the omni-directional radiation pattern in the azimuth plane, we need a metamaterial structure, and we should change the circuit in Fig. 1(b) to Fig. 2 as the CRLH equivalent configuration.

In Fig. 2, series C (C_L) plays the major role in changing the conventional patch to the CRLH antenna, which will be the coupling between the conventional patch and the proposed shorted ring. L_L ,

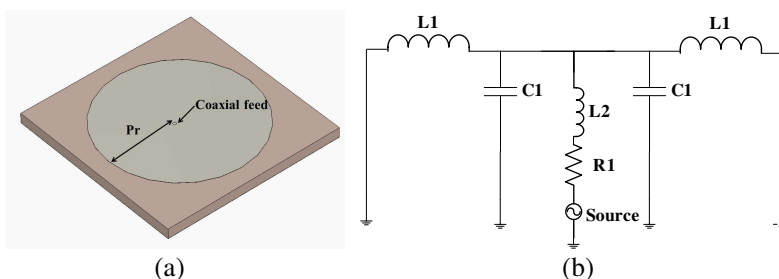

Figure 1. Conventional microstrip patch antenna. (a) Geometry, (b) equivalent circuit.

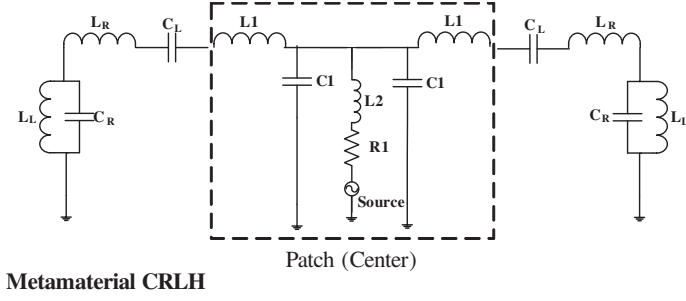

Figure 2. Equivalent circuit of the proposed CRLH microstrip antenna.

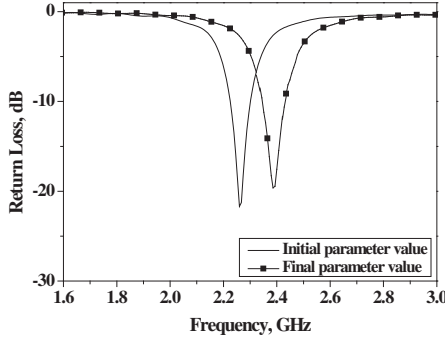

Figure 3. Conventional microstrip patch antenna: Return loss for the initial and final values of P_r .

C_R and L_R are also necessary to make the complete CRLH combined with L_1 , C_1 , and L_2 . All the lumped elements are calculated to achieve the ZOR at 2.4 GHz, and L_1 , L_2 , C_1 , L_R , C_L , C_R and L_L are 1 nH, 0.2 nH, 4.6 pF, 3 nH, 1.4 pF, 22 pF and 0.2 nH, respectively. From the following equations, also shown in [10].

$$\omega_L = \frac{1}{\sqrt{L_L C_L}}, \quad \omega_R = \frac{1}{\sqrt{L_R C_R}}, \quad \omega_{se} = \frac{1}{\sqrt{L_R C_L}}, \quad \omega_{sh} = \frac{1}{\sqrt{L_L C_R}},$$

$$\omega_0 = \sqrt{\omega_R \omega_L}, \quad Z_L = \sqrt{\frac{L_L}{C_L}}, \quad Z_R = \sqrt{\frac{L_R}{C_R}}, \quad Z_{se} = \frac{1 - \omega^2 L_R C_L}{j\omega C_L}, \quad (1)$$

$$Z_{sh} = \frac{j\omega L_L}{1 - \omega^2 L_L C_R}$$

where ω_L , ω_R , ω_{se} , and ω_{sh} are cut-off frequencies for LH, RH, series, and shunt resonance, respectively, and the geometric average of the cut-off frequencies should be ω_0 . Also, Z_L and Z_R are set to the characteristic impedance.

C_L , L_L , C_R and L_R as the circuit elements will be realized with the proposed geometry of the capacitive coupled circular shorted ring.

3. DESIGN RESULTS OF THE PROPOSED CRLH ZOR ANTENNA

Now the aforementioned equivalent circuits are changed to physical geometries. The initial geometrical dimensions can be obtained through the approximate formulas for the circuit elements, as similarly done in [9–11]. The initial geometries are drawn and adjusted in the CST-MWS as a 3D EM field simulator to have the resonance at the designated frequency. P_r is initially given by a formula from [9] concerned with $\lambda_g/2$. And P_r is iteratively varied in the field simulator. Its value is finalized as shown in Table 1.

Regarding the coaxial feeding, a circular patch of radius 23.4 mm is needed to resonate at 2.4 GHz. With the geometry of Fig. 1(a), the return loss is given as follows.

As expected, S_{11} of the conventional patch antenna has the resonance at 2.4 GHz with the finalized P_r as checked in Fig. 3. In the later section of this paper, $\lambda_g/2$ E -field of the ordinary patch resonance mode will be presented.

It is time to illustrate and discuss the geometry of the proposed CRLH antenna. As mentioned earlier, the metamaterial antenna in this paper uses the conventional circular patch as the central patch for L_1 , L_2 and C_1 , and takes the circular shorted ring for C_L , L_L , C_R and L_R .

The shorted ring is made up of a metal strip loop supported by vias through the substrate from the ground. The surface of the metal strip loop provides L_R , and C_R . The vias correspond to L_L . The gap between the central patch and the shorted ring explains C_L . If the gap is small, its size is obtained from the capacitance between the parallel lines. The length of the vias determines the height of the metal loop, which is the shunt inductance obtained through an approximate

Table 1. Conventional microstrip patch: rADIUS.

	Initial value	Final value
Resonance frequency	2.25 GHz	2.4 GHz
P_r	24.7 mm	23.4 mm
Substrate thickness	3.175 mm	3.175 mm
$\tan \delta$	0.0009	0.0009

formula.

$$X_p = \omega L_p = \eta_0 \mu_r \left(\frac{h}{\lambda_0} \right) \left[-\gamma + \ln \left(\frac{2}{\sqrt{\mu_r \epsilon_r k_0 a}} \right) \right] \quad (2)$$

Through the iterative 3D EM simulations to meet the equivalent circuit simulation result, the geometry is determined as follows.

As part of the process to find the final structure, we carry out the parametric studies that vary the physical dimensions and ϵ_r until the desired result is obtained. First, we select the different values of ϵ_r for the substrate. They are 1.0, 2.2 (RT Duroid 5880) and 4.4 (FR4). These numbers are realistic. Also, for the resonance at 2.4 GHz, the length of the patch should be roughly inversely proportional to the different ϵ_r . Here comes the return loss along with the gain at the resonance mode.

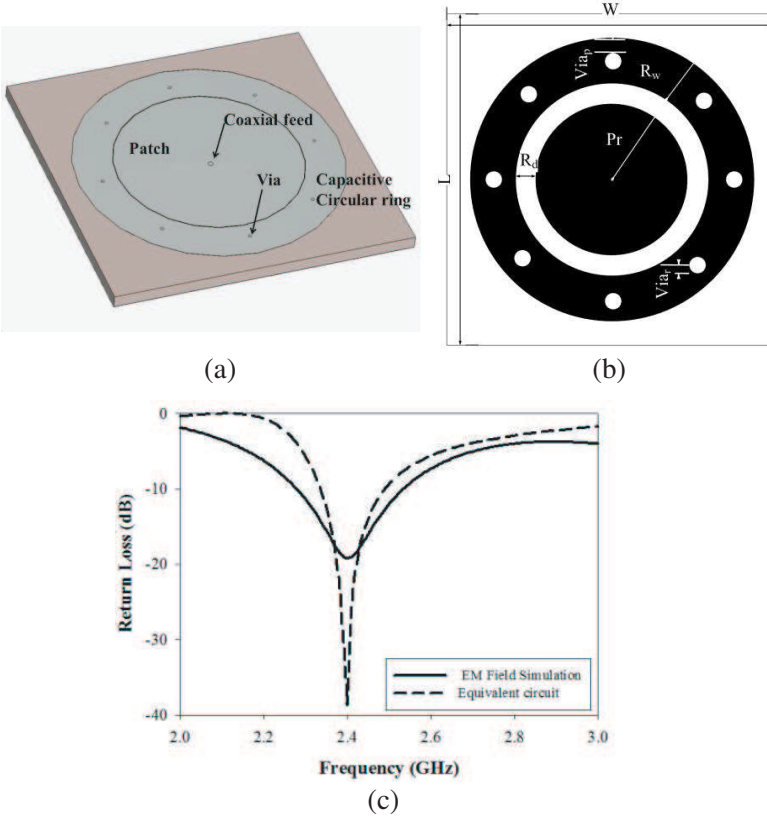

Figure 4. Proposed ZOR patch antenna. (a) 3D view of the geometry, (b) top view, (c) circuit and EM simulations.

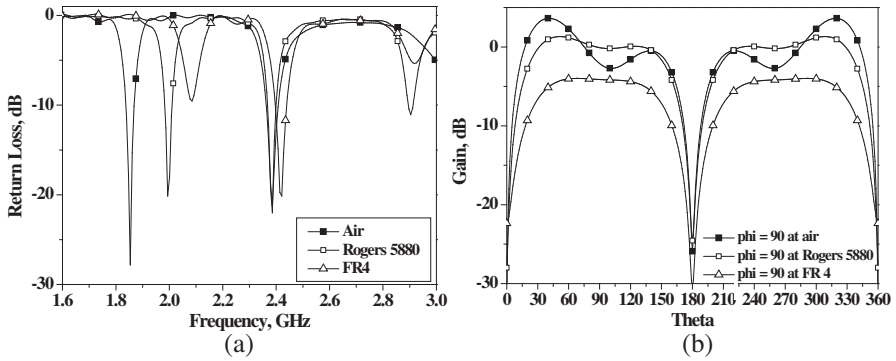

Figure 5. Frequency response and antenna gain VS. different ϵ_r . (a) Return loss. (b) Radiation pattern at the ZOR VS. the elevation angle: Parameters are $\text{via}_r = 0.4 \text{ mm}$, the number of the $\text{vias}_s = 8$, $R_d = 0.1 \text{ mm}$.

Table 2. Physical dimensions.

$\epsilon_r = 2.2$,	thickness = 3.175 mm,	metal thickness = 1 oz,
$W = L = 76.8 \text{ mm}$,	$P_r = 23.4 \text{ mm}$,	$R_w = 10 \text{ mm}$,
$R_d = 0.1 \text{ mm}$,	$\text{via}_p = 6 \text{ mm}$,	$\text{via}_r = 0.4 \text{ mm}$
and the number of the vias = 8		

As shown in Fig. 5, all the three cases have both the ZOR and the -1st resonance mode, as the proposed CRLH antenna. The monopolar patterns at 2.4 GHz in Fig. 5(b) prove the MTM ZOR characteristic. Since we set and fix 2.4 GHz as the ZOR for all the cases, they do not move, but the -1st resonance mode varies upward with increasing ϵ_r . Besides, the ZOR radiation patterns show the higher ϵ_r becomes, the lower the antenna gain gets. Therefore, we choose $\epsilon_r = 2.2$ for our final design in terms of the size, the pattern and the antenna gain.

Next parametric studies go with the radius of the vias which is related to the number and distance of the vias and the distance between a via and the outer edge of the metal loop, and P_r . The number of the vias is set 8, ϵ_r is 2.2, the gap is 0.1 mm. Fig. 6 presents their frequency responses.

When via_r and via_p are changed, they mainly affect the current path on the metal strip, thus L_R . This causes the ZOR to move, while the -1st resonance mode barely changes, as shown in Figs. 6(a) and (b). When P_r becomes 18 mm, the -1st and ZOR frequencies move upward as shown in Fig. 6(c), where the circuit and EM simulations have very similar behaviors.

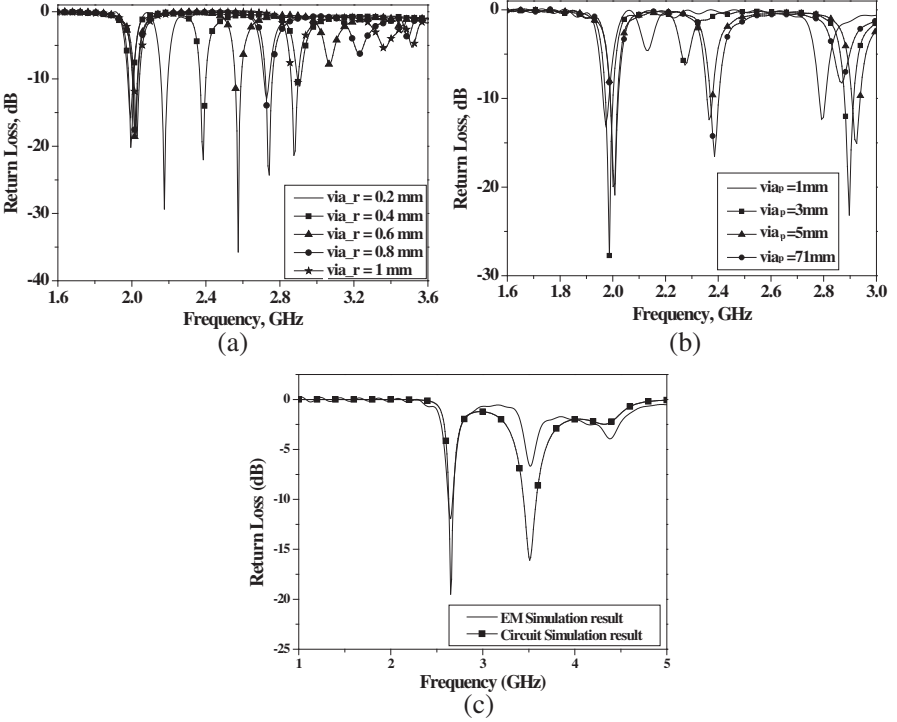

Figure 6. Return loss VS. patch radius, via_r or via_p . (a) Changing via_r , (b) changing via_p , (c) changing P_r .

Going through all the possible parametric studies including the above, we find out the following values are proper for the physical dimensions as well as the substrate: $\epsilon_r = 2.2$ and thickness = 3.175 mm for RT Duroid5880, $W = L = 76.8$ mm, $P_r = 23.4$ mm, $R_w = 10$ mm and $R_d = 0.1$ mm, $via_p = 6$ mm and $via_r = 0.4$ mm, which are summarized in Table 2. Taking into account all these values in the 3D EM field simulation, the proposed metamaterial ZOR antenna has the following frequency responses and unique metamaterial E -field distributions and far-field patterns.

Figure 7(a) shows the return loss of the conventional patch and the proposed antenna. The proposed antenna is a DNG type antenna and has the ZOR at 2.4 GHz and the -1 st resonance mode at 2 GHz. While the conventional patch has the out-of-phase resonance at 2.4 GHz as the $\lambda_g/2$ resonance shown in Fig. 7(b), the metamaterial properties of the proposed antenna become obvious with the E -field distributions of the no-phase variation at the ZOR of 2.4 GHz shown in Fig. 7(d), and small-sized out-of-phase variation at the -1 st resonance mode of

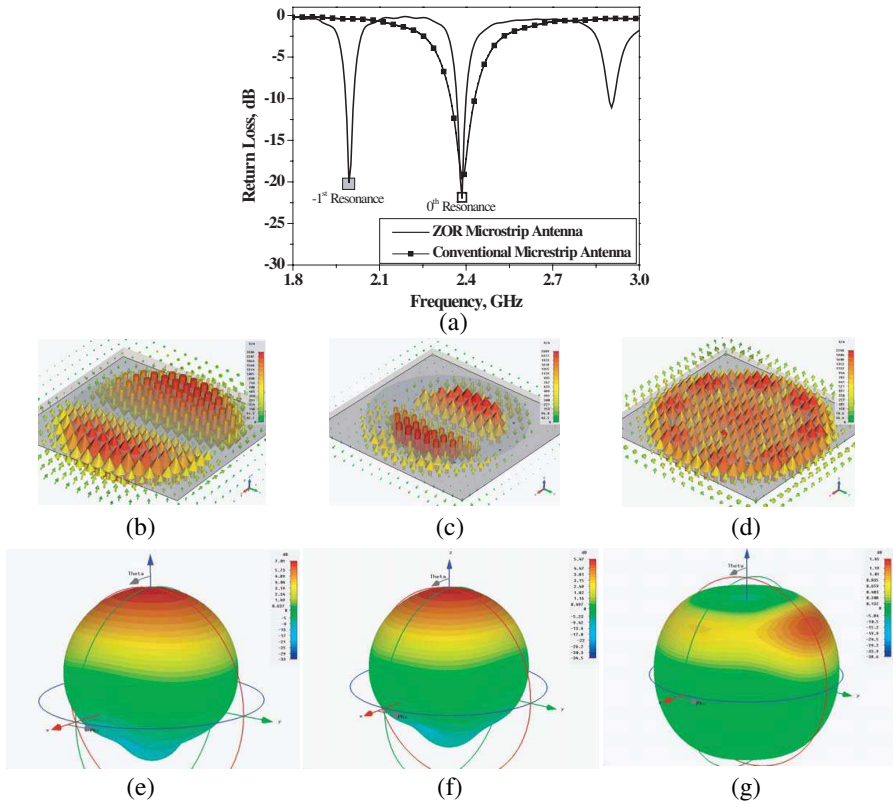

Figure 7. Comparison of the return loss, E -field distributions, radiation patterns between the conventional patch and proposed 2D-CRLH antenna. (a) S_{11} , (b) $\lambda_g/2$ E -field distribution of the conventional patch at 2.4 GHz, (c) E -field distribution at the -1 st resonance mode of the proposed antenna at 2 GHz, (d) ZOR of the proposed antenna at 2.4 GHz, (e) radiation pattern at $\lambda_g/2$ mode of the conventional patch at 2.4 GHz, (f) radiation pattern at the -1 st mode of the proposed antenna at 2 GHz, (g) monopolar radiation pattern at the ZOR of the proposed antenna.

2 GHz shown in Fig. 7(c). The unique metamaterial features of the proposed antenna is proven by the monopolar radiation pattern at the ZOR shown in Fig. 7(g) as well as the broadside radiation pattern at the -1 st resonance mode at 2 GHz shown in Fig. 7(f). At this point, we can judge the proposed antenna has the size minimization effect in that it plays the extremely low-profile monopole for the ZOR (height of this antenna = 3.175 mm and that of a monopole = 90 mm, volume reduction effect = 30^3), and the smaller planar antenna of the

–1st resonance as the lower frequency having the broadside radiation pattern at a frequency below the ZOR frequency. Especially, to get generally useful radiation patterns and acceptable gain for different frequencies in one structure, the proposed antenna makes advantages over the conventional combination of the individual 2 GHz antenna and the individual 2.4 GHz antenna, because a 2 GHz antenna has its harmonic 4 GHz and it can not hold a slot for 2.4 GHz resonance whose size exceeds the 2 GHz patch. This explains the size reduction by the negative resonance of the proposed antenna.

Finally, the proposed antenna is fabricated with the same physical dimensions and substrate as the 3D EM simulation above. Thus the measurement of the physically implemented antenna presents the following performances.

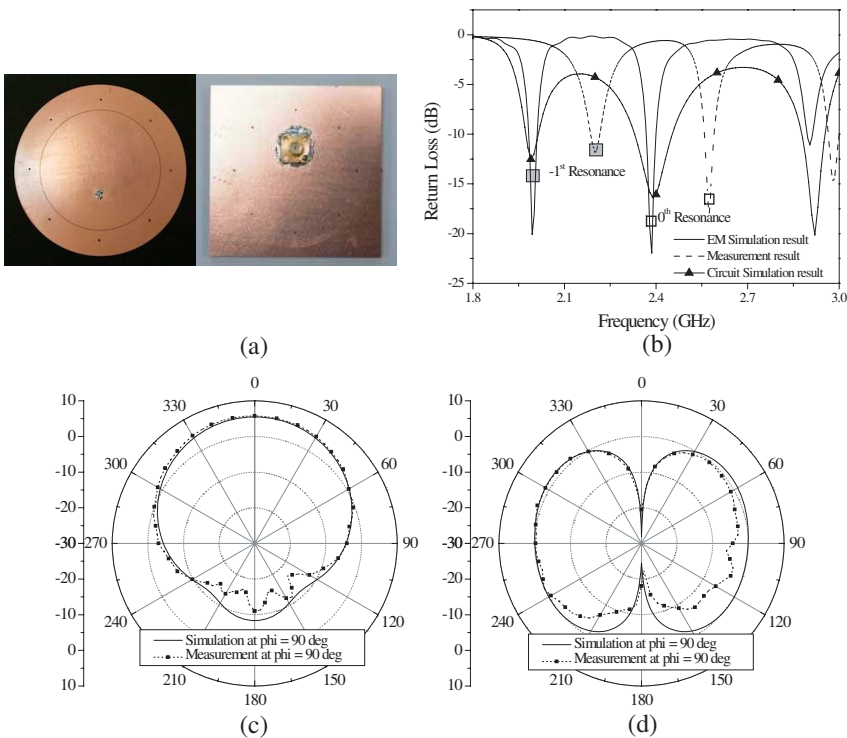

Figure 8. Measurement of the fabricated proposed 2D CRLH antenna. (a) Top and bottom views of the antenna. (b) Measured and simulated S_{11} . (c) Radiation pattern at the –1st mode of the proposed antenna, simulated at 2 GHz and measured at 2.2 GHz. (d) Monopolar radiation pattern at the ZOR of the proposed antenna, simulated at 2.4 GHz and measured at 2.5 GHz.

Figure 8(a) is the photo of the fabricated antenna which looks the same as Fig. 4(a). The return loss of this proposed antenna is measured in the first place. The resonance frequencies (2.2 GHz and 2.5 GHz) of the measurement are shifted from those (2 GHz and 2.4 GHz) in the circuit and EM simulation due to the manufacturing tolerance affecting the gap, via radii, a real connector, gluing/soldering and ϵ_r error (possibly non-uniform over the substrate slab and roughness) and test environment. Especially, the discrepancy is attributed to the change in the gap from 0.1 mm to 0.17 mm. Despite the resonance frequency shift, 2.2 GHz and 2.5 GHz of the measurement still keep the metamaterial characteristics of 2 GHz and 2.4 GHz, respectively, which is proven by the radiation patterns that are generated for the -1 st resonance and ZOR modes. The monopolar pattern of gain 2.36 dBi is achieved at 2.5 GHz shifted from the ZOR at 2.4 GHz. Besides, the -1 st resonance mode far-field pattern of gain 2.23 dBi is obtained at 2.2 GHz in the measurement the same as that of 2 GHz in the simulation.

4. CONCLUSION

In this paper, a novel metamaterial CRLH ZOR Circular microstrip patch antenna is proposed, which comprises 1 circular patch capacitively coupled to 1 circular ring mushroom to have a monopole antenna pattern due to the completely closed loop of a magnetic current around the structure, and reduced profile and size due to the Left-handedness. The antenna is designed and modeled with the equivalent circuits and verified by the 3D EM simulation of the physical structure. The no-phase variation at the ZOR and the -1 st resonance mode are proven with electric field distributions and far-field patterns. The measurement shows there exist the ZOR and the -1 resonance mode despite the frequency shift from the simulation, which is proven by the monopolar pattern and broadside radiation, respectively. Also the proposed antenna turns out effective in size minimization as the low-profile monopole at the ZOR and the lower frequency resonance at a higher frequency size. Hence, the suggested design method will be applicable to the antennas for surface mountable vehicles and miniaturized wireless communication systems.

ACKNOWLEDGMENT

This work was supported by the research promotion program of the university of Incheon in 2011.

REFERENCES

1. Caloz, C. and T. Itoh, *Electromagnetic Metamaterials: Transmission Line Theory and Microwave Application*, Wiley & Sons, 2006.
2. Jang, G. and S. Kahng, "Design of a metamaterial bandpass filter using the zor of a modified circular mushroom structure," *Microwave Journal*, Vol. 54, No. 5, 158–167, May 2011.
3. Lai, A., C. Caloz, and T. Itoh, "Composite right/left-handed transmission line metamaterials," *IEEE Microwave Magazine*, Vol. 5, No. 3, 34–50, Sep. 2004.
4. Lee, C.-J., K. M. K. H. Leong, and T. Itoh, "Composite right/left-handed transmission line based compact resonant antennas for RF module integration," *IEEE Trans. on Antennas and Propagat.*, Vol. 54, 2283–2291, Aug. 2006.
5. Lai, A., K. M. K. H. Leong, and T. Itoh, "Infinite wavelength resonant antennas with monopolar radiation patterns based on periodic structures," *IEEE Trans. on Antennas Propagat.*, Vol. 55, No. 3, 868–876, Mar. 2007.
6. Kim, J. and J. Choi, "Dual band MIMO antenna using ENG zeroth order resonator for 4G system," *IEEE International Workshop on Antenna Technology, iWAT*, 1–4, Oct. 2009.
7. Gomez-Diaz, J. S., A. Álvarez-Melcon, and T. Bertuch, "A modal-based iterative circuit model for the analysis of crlh leaky-wave antennas comprising periodically loaded PPW," *IEEE Transactions on Antennas and Propagation*, Vol. 59, No. 4, 1101–1112, Apr. 2011.
8. Lee, J.-G. and J.-H. Lee "Zeroth order resonance loop antenna," *IEEE Trans. on Antennas and Propagat.*, Vol. 55, No. 3, 994–997, Mar. 2007.
9. Jang, G., S. Kahng, J. Ju, J. Anguera, and J. Choi, "A novel metamaterial CRLH ZOR microstrip patch antenna capacitively coupled to a rectangular ring," *IEEE Antennas and Propagation Society International Symposium (APSURSI)*, Toronto, Jul. 11–17, 2010.
10. Jang, G. and S. Kahng, "Design of a dual-band metamaterial bandpass filter using zeroth order resonance," *Progress In Electromagnetics Research C*, Vol. 12, 149–162, 2010.
11. Balanis, A., *Antenna Theory: Analysis and Design*, John Wiley & Sons, 1997.