

A NOVEL MINIATURIZED BANDPASS FILTER BASED ON COMPLEMENTARY SPLIT RING RESONATORS (CSRRs) AND OPEN-LOOP RESONATORS

M. Keshvari and M. Tayarani

Department of Electrical Engineering
Iran University of Science and Technology (IUST), Tehran, Iran

Abstract—A microstrip bandpass filter is presented based on Complementary Split Ring Resonators (CSRRs) and a pair of open-loop resonators that has a single pair of transmission zeros at finite frequencies that causes an improvement at skirt response. An equivalent circuit is introduced to make analysis and optimization faster. Finally a filter is designed using the proposed cell and the simulation results with both equivalent model and full wave analysis are in very good agreement. The filter was fabricated and the measurement result was also in good agreement with simulation results. Besides, the size of the designed filter is very small and it occupies an area less than $0.23\lambda_g \times 0.16\lambda_g$, where λ_g is the guided wavelength at the midband frequency.

1. INTRODUCTION

With the very rapid growth of microwave/millimeterwave technology and their applications, the circuit size is becoming more and more important. Several investigations are focused on miniaturization of microwave circuits while keeping the performance good and the price low. Filters, as indispensable components in communication systems, have a significant role to achieving this goal.

One of the basic concepts achieved in this paper is introducing a new type of compact filter based on complementary split ring resonators (CSRRs) that were first proposed by Falcone et al. [1]. Now, CSRRs are used widely for the synthesis of resonant type metamaterial transmission lines ([2–5, 15]).

Received 30 March 2011, Accepted 29 April 2011, Scheduled 9 May 2011

Corresponding author: Mohammad Keshvari (keshvari.mohammad@gmail.com).

It is demonstrated that periodically loading a host (Microstrip) line with CSRRs (etched in the ground plane) results in a one-dimensional effective medium with negative permittivity in a narrow frequency band below the resonance frequency of the CSRRs [1, 4]. By adding series capacitive gaps above the positions of the CSRRs, a negative effective permittivity and permeability simultaneously arise and the structure exhibits left handed wave propagation [3]. The small size of the unit cell of such artificial lines leads us to several applications of CSRR-loaded lines in circuit miniaturization.

Another basic part that we have used in our proposed filter is a square open-loop resonator. Obviously, placing transmission zeros near the cutoff frequencies of the passband, improves the filter's selectivity. The basic idea to realize transmission zeros is cross coupling between a pair of nonadjacent resonators. One cross-coupled planar structures is the square open-loop resonators [7, 8]. An open-loop resonator is essentially a folded half-wavelength resonator that can be considered as a building block for planar microstrip filters. Based on these structures and cross-coupling concept, design of some advanced filters, such as cascaded quadruplet (CQ) filters, trisection and cascaded trisection (CT) filters. are accomplished by some authors ([10–12]).

The contribution of this work is offering a new planar cell that is composed of CSRR structure etched in microstrip ground plane and a pair of square open-loop resonators in the signal layer as shown in Figure 1. The advantage of this novel structure over the basic CSRR cell (Figure 2(a)) is a considerable increase in upper stop band rejection, while the size of structure is kept small.

Another important aim of this letter is introducing an equivalent circuit for proposed structure that paves the way of filter analysis and designing.

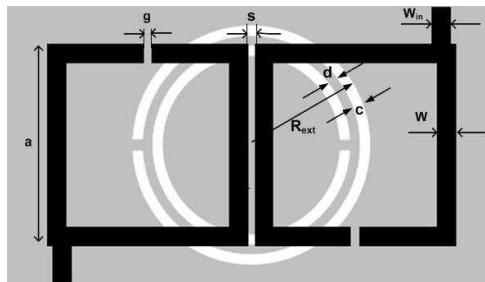

Figure 1. Layout of our proposed CSRR-open loop resonator based filter. The upper metallization is depicted in black, and the bottom metal region (ground) is depicted in gray.

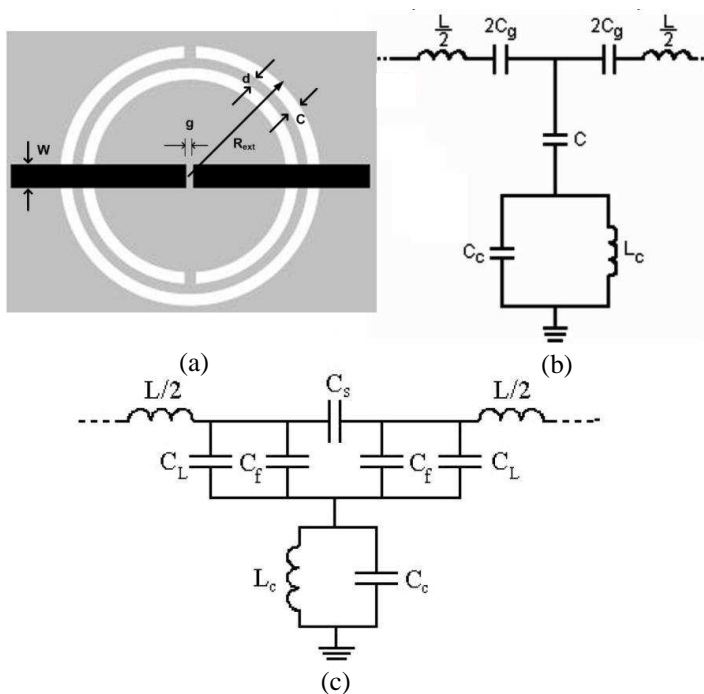

Figure 2. Topology of the basic cell of (a) CSRR-based transmission line and (b) lumped element equivalent circuit model. (c) Improved equivalent circuit model. Ground plane metal is depicted in gray whereas upper metal level is depicted in black.

2. STRUCTURE DESCRIPTION, EQUIVALENT CIRCUIT MODEL AND DESIGN CONSIDERATIONS

2.1. Frequency Characteristics

A typical unit cell of a microstrip line loaded with CSRRs and its lumped element equivalent T-circuit model are depicted in Figures 2(a) and 2(b), respectively. In this model, which has been reported before [4], L is the line inductance, C_g is the gap capacitance, C is the coupling capacitance between the line and the CSRR, and C_c and L_c model the reactive elements of the CSRR that are described by parallel resonant tanks. Recently, a new π equivalent circuit of Figure 2(c) has been introduced [6]. It describes the series gap and the coupling between the line and the CSRR more accurately. In this model C_L is the line capacitance, C_f is the fringing capacitance of the gap and C_s is the series capacitance of the gap.

The extraction of electrical model elements for a single-cell CSRR loaded line (Figure 2(b)) is based on geometrical parameters of the CSRR, that is dedicated in Figure 2(a) [5].

On the other hand, from π -T transformation, C_g and C can be expressed in terms of C_s and $C_{par} = C_f + C_L$ according to [6]:

$$C_g = 2C_s + C_{par} \quad (1)$$

$$C = \frac{C_{par}(2C_s + C_{par})}{C_s} \quad (2)$$

In view of the T model, two characteristic frequencies can be identified: the transmission zero frequency (that nulls the shunt impedance) and the intrinsic resonant frequency of the CSRR (that nulls the shunt admittance). These frequencies are given by the following expressions, respectively:

$$f_z = \frac{1}{2\pi\sqrt{L_c(C + C_c)}} \quad (3)$$

$$f_o = \frac{1}{2\pi\sqrt{L_c C_c}} \quad (4)$$

On the other hand, an open-circuited half wavelength transmission line behaves as a parallel resonant circuit. Assume a microstrip square open-loop resonator with the length l that $l = \lambda_g/2$ at $\omega = \omega_0$. For this parallel resonant circuit, the capacitance and inductance of the equivalent circuit are [9]:

$$C_{sr} = \frac{\pi}{2\omega_0 Z_0} \quad (5a)$$

$$L_{sr} = \frac{1}{\omega_0^2 C_{sr}} \quad (5b)$$

For square open-loop resonator coupling structures, a transmission zero is created above the resonant frequency as discussed above. The necessary and sufficient condition for realizing this transmission zero is $S_{12} = 0$. The creation mechanism of the transmission zero in the coupled resonators is discussed in [13, 14]. Therefore, in CSRR-open loop filters, we expect a transmission zero in both lower and upper bands caused by CSRR and open-loop resonators, respectively. This means a quasi-elliptic response is arisen.

It has been shown clearly in Section 2 by measuring the response of a fabricated sample filter as well as the full-wave and equivalent lumped element circuit simulation of it.

2.2. Lumped-element Circuit Model for Our Proposed Filter

According to previous explanation, we suggest an equivalent lumped-element circuit for our proposed filter (Figure 1) that is shown in Figure 3. In this model, two shunt parallel synchronous resonators with L_r and C_r represent the open-loop resonators. Two parallel resonators in the series arm (L_{sr} and C_{sr}) are added to each side for modeling the open-loop resonators transmission zero and these are identical to keep the model symmetric. Also, C_s represents the capacitance between two open loop resonators. C_L , C_f , C_c and L_c model the CSRR as explained in pervious section. L and C_p are the inductance and capacitance of the line. This model not only makes the analysis and design of filter easier, but also yields the possibility of parametric analysis of proposed structure.

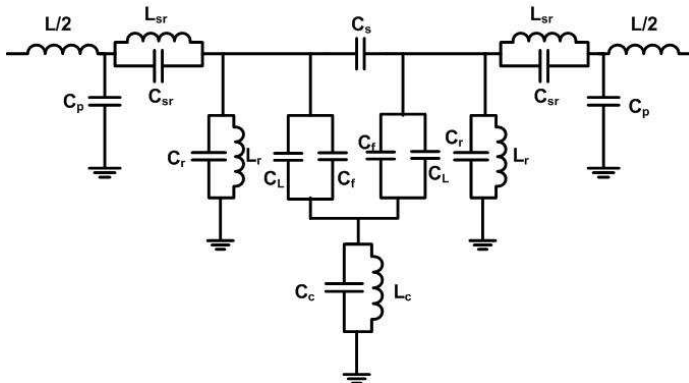

Figure 3. Proposed lumped-element circuit model for a CSRR open-loop filter.

Table 1. Extracted element parameters for the equivalent circuit model of fabricated filter as shown in Figure 6.

C_{sr} (pF)	L_{sr} (nH)	C_s (pF)	L_r (pF)	C_r (pF)	L_c (nH)
1.8	4	0.1	3.2	4.8	3.8
C_c (pF)	C_f (pF)	C_L (pF)	C_p (pF)	L (nH)	-
4	0.05	2.6	1.2	8	-

3. VALIDATION OF THE MODELS AND ILLUSTRATIVE RESULTS

The circuit models presented in the previous section have been validated by comparing experimental data and circuit simulations. We have designed and fabricated a filter based on a CSRR and a pair of open-loop Resonators on a CER-10 substrate ($\epsilon_r = 10$, $h = 0.635$ mm and $\tan \delta = 0.0023$). In this example, the dimensions of the structure (according to Figure 1) are: $R_{ext} = 6.5$ mm, $c = 0.5$ mm, $d = 0.6$ mm, $a = 11.4$ mm, $W = 1$ mm, $g = 0.5$ mm, $s = 0.4$ mm and $W_{in} = 0.63$ mm for achieving 50Ω .

The electrical parameters of the aforementioned equivalent circuit

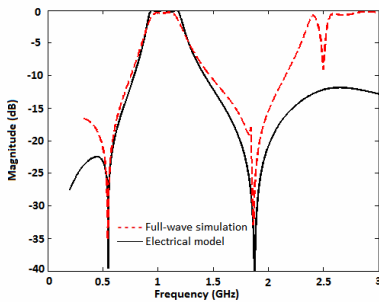

Figure 4. S_{21} of the filter based on full-wave simulation and electrical simulation of equivalent lumped element circuit model.

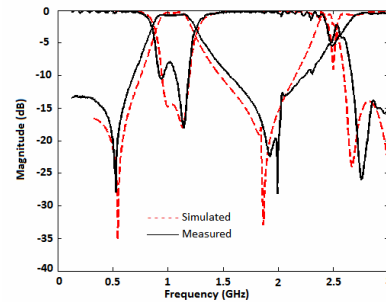

Figure 5. Measured S parameters of fabricated filter versus full-wave simulation response.

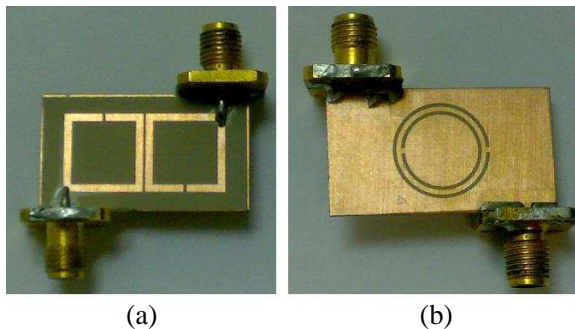

Figure 6. Fabricated filter with CSRR in ground plane. (a) Top view. (b) Bottom view.

model for this filter are shown in Table 1.

Finally, The comparison between full wave and electrical simulation responses is depicted in Figure 4. Also, the measured response of S parameters of this filter is shown in Figure 5. As can be seen, a reasonable agreement between theory and experiment is obtained. Figure 6 shows the photograph of fabricated filter. It is a really compact filter that occupies an area less than $0.23\lambda_g \times 0.16\lambda_g$, where λ_g is the guided wavelength at the midband frequency.

4. CONCLUSION

We have shown that a CSRR combined with a pair of open-loop resonators can be used for the design of a novel filter with two transmission zeros, which one of them is due to the CSRR intrinsic transmission zero and the other is because of the open-loop resonators.

Suggestion of an equivalent lumped element circuit model for proposed filter was another important aim of this letter

ACKNOWLEDGMENT

This work has been supported by ITRC. The authors are grateful to this institute for their support.

REFERENCES

1. Falcone, F., T. Lopetegi, J. D. Baena, R. Marqués, F. Martín, and M. Sorolla, "Effective negative- ϵ stop-band microstrip lines based on complementary split ring resonators," *IEEE Microwave Wireless Compon. Lett.*, Vol. 14, 280–282, 2004.
2. Marqués, R., J. Martel, F. Mesa, and F. Medina, "Left handed media simulation and transmission of EM waves in sub-wavelength SRR-loaded metallic waveguides," *Phys. Rev. Lett.*, Vol. 89, 183901(1)–183901(4), 2002.
3. Falcone, F., T. Lopetegi, M. A. G. Laso, J. D. Baena, J. Bonache, R. Marqués, F. Martín, and M. Sorolla, "Babinet principle applied to the design of metasurfaces and metamaterial," *Phys. Rev. Lett.*, Vol. 93, 197401, 2004.
4. Baena, J. D., J. Bonache, F. Martín, et al., "Equivalent-circuit models for split-ring resonators and complementary split-ring resonators coupled to planar transmission lines," *IEEE. Trans. Microw. Theory Tech.*, Vol. 53, No. 4, 1451–1461, Apr. 2005.

5. Bonache, J., M. Gil, I. Gil, J. García-García, and F. Martín, "On the electrical characteristics of complementary metamaterial resonators," *IEEE Microw. Wireless Compon. Lett.*, Vol. 16, No. 10, 543–545, Oct. 2007.
6. Bonache, J., M. Gil, O. García-Abad, and F. Martín, "Parametric analysis of microstrip lines loaded with complementary split ring resonators," *Microw. and Opt. Tech. Lett.*, Vol. 50, No. 8, Aug. 2008.
7. Hong, J.-S. and M. J. Lancaster, "Couplings of microstrip square open-loop resonators for cross-coupled planar microwave filters," *IEEE Trans. Microwave Theory Tech.*, Vol. 44, 2099–2109, Nov. 1996.
8. Hong, J.-S. and M. J. Lancaster, "Canonical microstrip filter using square open-loop resonators," *IEEE Electron. Lett.*, Vol. 31, No. 23, 2020–2022, Nov. 1995.
9. Pozar, D. M., *Microwave Engineering*, 3rd edition, Chapter 6, Wiley, New York, 2005.
10. Hong, J.-S. and M. J. Lancaster, *Microstrip Filters For RF/Microwave Applications*, Wiley, 2001.
11. Hong, J.-S. and M. J. Lancaster, "Microstrip cross-coupled trisection bandpass filters with asymmetric frequency characteristics," *IEE Proc. Microw. Antennas Propag.*, Vol. 146, No. 1, 84–90, Feb. 1999.
12. Levy, R., "Direct synthesis of cascaded quadruplet (CQ) filters," *IEEE Trans. Microwave Theory Tech.*, Vol. 43, 2940–2944, Dec. 1995.
13. Tsai, C.-M., S.-Y. Lee, and C.-C. Tsai, "Performance of a planar filter using a zero-degree feed structure," *IEEE Trans. Microwave Theory Tech.*, Vol. 50, 2362–2367, 2002.
14. Zhou, L., S. Liu, H. F. Zhang, X.-K. Kong, and Y.-N. Guo, "Compact dual-band bandpass filter using improved split ring resonators based on stepped impedance resonator," *Progress In Electromagnetics Research Letters*, Vol. 23, 57–63, 2011.
15. Fallahzadeh, S. and M. Tayarani, "A compact microstrip bandstop filter," *Progress In Electromagnetics Research Letters*, Vol. 11, 167–172, 2009.