

## **A MODIFIED UWB WILKINSON POWER DIVIDER USING DELTA STUB**

**B. Zhou, H. Wang, and W.-X. Sheng**

School of Electronics and Optical Engineering  
Nanjing University of Science and Technology  
Nanjing, Jiangsu 210094, China

**Abstract**—A modified UWB power divider formed by implementing one delta stub on each branch is proposed. Delta stub is used as a substitution of radial stub that can present wideband characteristic. The proposed structure makes branch line shorter and stub's size smaller than those of similar works based on UWB power divider using radial stub. It also achieves a compact size of 18 mm by 13 mm. The simulation and measurement results of the developed divider are presented and shown good agreement in the UWB range.

### **1. INTRODUCTION**

The Wilkinson power dividers and combiners are very important components for microwave and millimeter-wave circuits including power amplifiers, mixers and phased-array antennas. Ultra-wideband (UWB) wireless communication systems require their radio frequency components to operate in UWB range. Therefore, components that work from 3.1 to 10.6 GHz are of great interest. UWB power divider is one of the most useful components in various microwave circuits. In recent years, many new types of power dividers for the UWB application have been proposed in [1–4]. Normally, wideband power divider [5] can be achieved by cascading multi-section matching networks at two output ports of a single Wilkinson power divider or using multilayer PCB technology. However, those approaches increase the size and insertion loss of the circuit, and it requires more resistors for output ports' isolation. By installing a pair of open-circuited rectangular stub, UWB power divider is proposed in [6, 7]. Recently, a UWB power divider based on radial stub was developed [8], and it exhibited good power splitting performance over the UWB range.

---

*Received 18 October 2010, Accepted 15 November 2010, Scheduled 22 November 2010*  
Corresponding author: Bo Zhou (sarahxboy@hotmail.com).

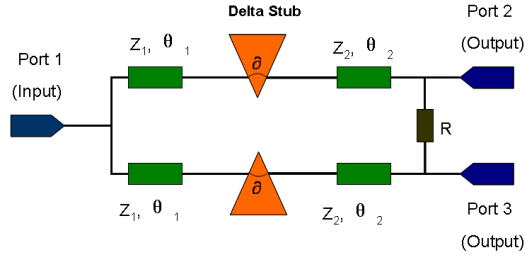

**Figure 1.** The schematic diagram of the proposed UWB power divider.

Delta stub was first proposed by De Lima Coimbra [9]. Its shape is an isosceles triangle as Greek letter “Delta”. Although delta stub has been proposed for a long time, it is seldom used as impedance match element in microwave components design. Like radial stub, delta stub can present wider bandwidth. Compared with radial stub, delta stub is a good alternative to be the radial stub, and it is useful in wherever a radial stub would be chosen and has simpler contour due to its straight sides, so it is easier to lay out on PCB.

In the paper, we design an UWB power divider with delta stubs. As far as we know, it is the very first time that delta stub is used as impedance match element in power divider’s design. With the proposed delta stub, the overall divider length and stub size can be reduced compared with the one in [8], and it is easier for designer to lay out than a radial stub. The simulated and measured results of the proposed divider show good return loss, insertion loss and isolation performance across the band from 3.1 to 10.6 GHz.

Figure 1 shows the schematic diagram of the proposed UWB power divider modified from the one proposed by Ahmed and Sebak in [8]. Here, single open radial stub of each branch is substituted by a delta stub. The reason for using delta stub instead of radial ones is to obtain shorter branch line, smaller stub and easier layout. By adjusting dimension parameter of delta stub, the bandwidth can be broadened.

The impedances of input and output ports of the proposed power divider are both  $50\ \Omega$ , and the characteristic impedance of the first and second branch transmission lines are  $Z_1 = Z_2 = 83\ \Omega$ . The electrical lengths of the first and second transmission lines are  $\theta_1 = 35.64^\circ$  and  $\theta_2 = 29.83^\circ$  at the center frequency of 6.85 GHz, respectively. So the length of branch line ( $L_1 + L_2 + W_g$ ) is much shorter than traditional Wilkinson power divider with  $90^\circ$  branch line. Since this divider is symmetric, the even and odd mode analysis can be used to determine the parameters for the proposed UWB divider.

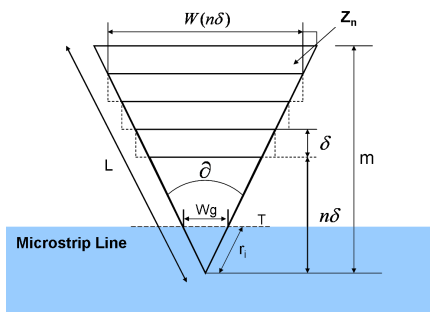

**Figure 2.** Geometry of the delta stub.

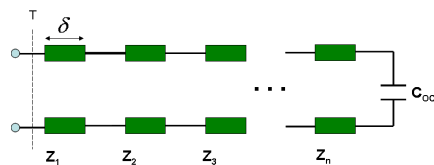

**Figure 3.** Equivalent circuit of delta stub.

Coimbra and Mauro [10] recommend modeling the delta stub by a series of  $n$  transmission line segments of length  $\delta$ . The open end of the delta stub is transferred by the equivalent line length to a short circuit at the reference plane  $T$ , shown in Fig. 2 and Fig. 3. Tapered line can be treated as a series of transmission line with different characteristic impedances. The number,  $n$ , is chosen so that each segment is  $\delta \ll \lambda_g$  in length. Each segment's characteristic impedance is calculated with the standard microstrip line equations with the exception of the final section, which includes the open end discontinuity. Widths of each transmission line are computed by

$$W = 2n\delta \operatorname{tg}(\delta/2) \quad n = 0, 1, \dots, x \tag{1}$$

where  $\delta$  is vertex angle of the delta stub in Fig. 2. Thus when  $W/d \geq 1$ , it is convenient to calculate the characteristic impedance of each segment by

$$Z_0 = \frac{120\pi}{\sqrt{\epsilon_e} [W/d + 1.393 + 0.667 \ln(W/d + 1.444)]} \tag{2}$$

$$\epsilon_e = \frac{\epsilon_r + 1}{2} + \frac{\epsilon_r - 1}{2} \frac{1}{\sqrt{1 + 12d/W}} \tag{3}$$

where  $\epsilon_r$  is the dielectric constant of PCB substrate, and  $\epsilon_e$  is the effective dielectric constant of a microstrip line.  $d$  is the thickness of PCB substrate.

The relation between the width of the feeding line  $Wg$  and inner radius  $r_i$  of the delta stub is given by

$$Wg = 2r_i \sin \frac{\delta}{2} \tag{4}$$

For a load impedance  $Z_L$ , input impedance of a lossless transmission line with length  $L$  and characteristic impedance of  $Z_0$  can be computed

by

$$Z_{in}(l) = Z_0 \frac{Z_L + jZ_0 \operatorname{tg} \beta l}{Z_0 + jZ_L \operatorname{tg} \beta l} \quad (5)$$

where  $\beta$  is the phase constant of the transmission, and  $Z_L$  is impedance of the last transmission line segment  $Z_n$ , so  $Z_L$  is

$$Z_L = \frac{120\pi}{\sqrt{\varepsilon_e} [W_{(n\delta)}/d + 1.393 + 0.667 \ln(W_{(n\delta)}/d + 1.444)]} \quad (6)$$

Since delta stub is considered as the cascaded interconnections of transmission line with equal incremental distance of  $\delta$ , the input impedance at  $m + \delta (\Delta Z = Z_{in} + dZ_{in})$  is

$$\Delta Z = Z_0 \frac{Z_{in} + jZ_0 \operatorname{tg}(\beta\delta)}{Z_0 + jZ_{in} \operatorname{tg}(\beta\delta)} \quad (7)$$

The input impedance of the delta stub can be found from the computation of the input impedance of each cascaded transmission line with incremental distance  $\delta$  successfully.

According to (1)–(7) and with the help of CAD program optimization, we set the segments quantity  $n$  as 100 for calculating impedance of the delta stub, then electrical parameters for the delta stub are derived as  $W_g = 1.1$  mm,  $L = 1.71$  mm,  $r_i = 1.14$  mm and  $\alpha = 58^\circ$ . Those parameters of delta stub are well matched with branch lines' impedance  $Z_1$  and  $Z_2$  in order to obtain wide bandwidth. And a 100  $\Omega$  resistor is used to enhance output ports' isolation.

## 2. SIMULATION AND MEASUREMENT RESULTS

AWR EMSight simulator [11] which is a full-wave electromagnetic solver in Microwave Office 2008 is used for the simulation of UWB

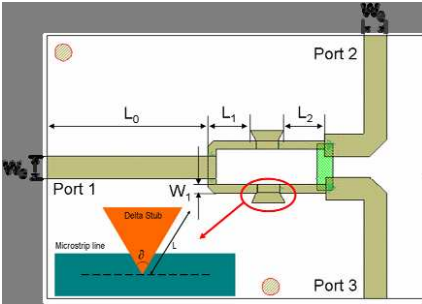

**Figure 4.** Layout of the proposed UWB power divider.

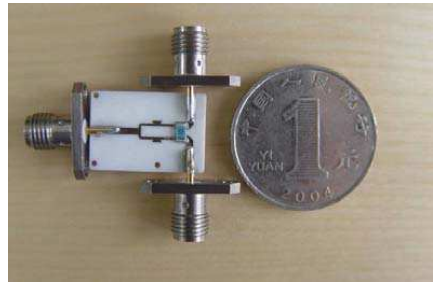
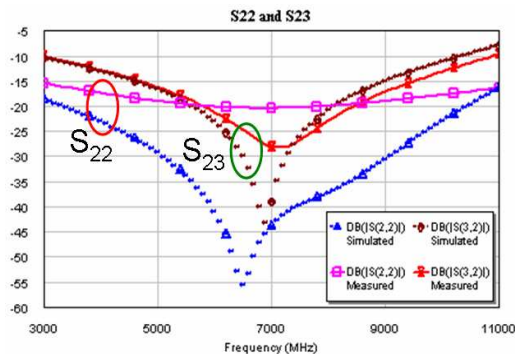
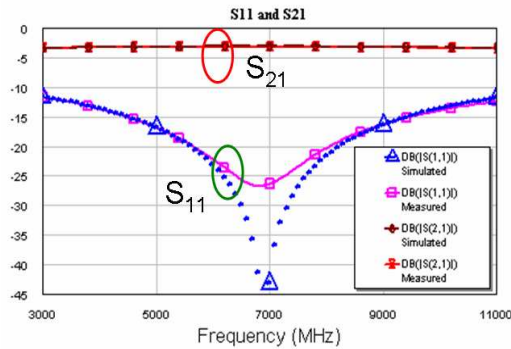

**Figure 5.** Photograph of the proposed UWB power divider.

power divider. To acquire a wideband in which the input return loss, output return loss and isolation between two output ports are less than the criteria of 10 dB. Many dimensions of the power divider have been simulated. By optimization with software Microwave Office 2008, we set dimension parameters of the proposed UWB power divider as:  $W_0 = 1.14$  mm,  $L_0 = 8$  mm,  $L_1 = 2.76$  mm,  $L_2 = 2.31$  mm,  $L = 1.71$  mm,  $\alpha = 58^\circ$  and  $R = 100\ \Omega$ , shown in Fig. 4. Length of branch line and stub become shorter than the one in [8].

The proposed UWB power divider is fabricated on the RO4003C substrate with a dielectric constant of 3.38 and a thickness of 0.508 mm. Fig. 5 shows a photograph of the proposed divider, and the overall dimension of the fabricated UWB power divider circuit is only 18 mm  $\times$  13 mm. All measured data are collected from the HP N5230A network analyzer. The simulated and measured  $S$ -parameters are presented in Fig. 6, respectively.

As shown in Fig. 6(a) and Fig. 6(b), the measured result of the insertion loss is better than 0.3 dB which indicates the proposed UWB



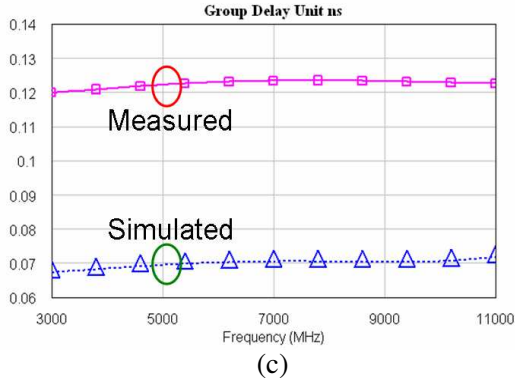

**Figure 6.** Simulated and measured parameters of proposed UWB power divider, (a)  $S_{11}$  and  $S_{21}$  parameters, (b)  $S_{22}$  and  $S_{23}$  parameters and (c) group delay parameter.

power divider can split an incoming signal into two parts successfully. The measured input return loss and output ports' isolation are better than  $-10$  dB, and output return loss is better than  $-15$  dB across the UWB range. Fig. 6(c) presents the simulated and measured group delay between the input and output ports. The group delay of the proposed UWB power divider is almost constant and less than  $0.13$  ns which shows good linearity within the UWB frequency range. The discrepancy between measured and simulated results of the group delay is caused by tolerance of PCB fabrication and soldering tolerance of  $100\ \Omega$  and SMA connectors.

### 3. CONCLUSION

A modified UWB power divider with delta stub on each branch is proposed and implemented. Shorter branch line, smaller stub and compact size have been achieved by using delta stub. Compared with radial stub, delta stub is easier to layout due to its straight sides. Good impedance matching, power splitting and isolation performance are achieved over the UWB range shown by simulation and measurement results.

### ACKNOWLEDGMENT

The authors would like to acknowledge the collaborative work with Nanjing Ericsson Company for PCB manufacturing.

## REFERENCES

1. Abbosh, A., "Multilayer inphase power divider for UWB applications," *Microwave Opt. Technol. Lett.*, Vol. 50, No. 5, 1402–1405, May 2008.
2. Lin, Z. and Q. X. Chu, "A compact spatial UWB power divider with 1 to 4 ways," *2008 Asia-Pacific Microwave Conference*, 1–4, 2008.
3. Bialkowski, M. and A. Abbosh, "Design of a compact UWB out-of-phase power divider," *IEEE Microw. Wireless Compon. Lett.*, Vol. 17, No. 4, 289–291, Apr. 2007.
4. Abbosh A., "A compact UWB three-way power divider," *IEEE Microw. Wireless Compon. Lett.*, Vol. 17, No. 8, 598–600, Aug. 2007.
5. Chieh, J. C. S and A. V. Pham, "Development of a wide bandwidth wilkinson power divider on multilayer organic substrates," *Microwave Opt. Technol. Lett.*, Vol. 52, No. 7, 1606–1609, Jul. 2010.
6. Wong, S. W. and L. Zhu, "Ultra-wideband power divider with good in-band splitting and isolation performances," *IEEE Microwave Wireless Compon. Lett.*, Vol. 18, No. 8, Aug. 2008.
7. Ou, X. P. and Q. X. Chu, "A Modified two-section UWB Wilkinson power divider," *ICMMT Proceedings*, 2008.
8. Ahmed, O. and A. R. Sebak, "A modified wilkinson power divider/combiner for ultrawideband communications," *IEEE Antennas and Propagation Society International Symposium*, 1–4, 2009.
9. De Lima Coimbra, M., "A new kind of radial stub and some applications," *Proc. XIV Eur. Microwave Conf.*, 516–521, Liege, Belgium, 1984.
10. Coimbra and L. Mauro, "The generalized delta stubs," *1987 International Microwave Symposium Proceedings*, 1071–1075, 1987.
11. Microwave Office software, AWR Design Environment Company, 2008.