

OPTICAL SOLITONS WITH HIGHER ORDER DISPERSION BY SEMI-INVERSE VARIATIONAL PRINCIPLE

P. D. Green

Applied Mathematics Research Center
Center for Research and Education in Optical Sciences and Applications
Department of Mathematical Sciences
Delaware State University
Dover, DE 19901-2277, USA

D. Milovic

Faculty of Electronic Engineering
Department of Telecommunications
University of Nis
Aleksandra Medvedeva 14, Nis 18000, Serbia

D. A. Lott

Department of Mathematical Sciences
Delaware State University
Dover, DE 19901-2277, USA

A. Biswas

Applied Mathematics Research Center
Center for Research and Education in Optical Sciences and Applications
Department of Mathematical Sciences
Delaware State University
Dover, DE 19901-2277, USA

Abstract—This paper studies optical solitons, in presence of higher order dispersion terms by the aid of He's semi-inverse variational principle. Both Kerr law and power law are taken into consideration. The numerical simulations are also given to complete the analysis.

1. INTRODUCTION

Optical Solitons is one of the major areas of research in the field of Nonlinear Optics. This area of research has made remarkable progress in the past few decades. One of the most important aspects that is studied in this area is the issue of integrability of the governing equation. There are various methods that are available that are used to carry out the integration of these governing equations. Some of these techniques are G'/G method, tanh-coth method, F -expansion method, exponential function method, Lie symmetry approach and many others [1–40]. These techniques lead to the integration of the governing equation although the Painleve test of integrability will indicate that the equations are not integrable.

The governing equation is the Nonlinear Schrödinger's equation (NLSE), that governs the propagation of solitons through optical fibers, through trans-continental and trans-oceanic distances [6, 8]. The NLSE falls under the category of nonlinear evolution equations in Partial Differential Equations. In this paper, one such method will be used to carry out the integration of the perturbed NLSE. This is called He's variational principle (HVP).

It needs to be noted that this principle was already applied to study optical solitons with Raman scattering, self-steepening, nonlinear dispersion as well as intermodal dispersion terms [17, 35]. Subsequently, this principle was applied to study the same perturbation terms but with full nonlinearity, where the nonlinear terms are generalized to an arbitrary exponent [35]. In this paper, HVP will be used to study optical soliton perturbation with higher order dispersion terms.

2. MATHEMATICAL ANALYSIS

The dimensionless form of the NLSE in a non-Kerr law media is given by [16]

$$iq_t + aq_{xx} + bF(|q|^2)q = 0, \quad (1)$$

where x and t represents the spatial and temporal variables respectively. The first term is the evolution term, The second term is the group velocity dispersion and the third term is the nonlinear term where the function F dictates the type of nonlinearity in question. The dependent variable q represents the wave profile and is a complex valued function. Solitons are the outcome of a delicate balance between dispersion and nonlinearity.

In (1), F is a real-valued algebraic nonlinear function and it is necessary to have the smoothness of the complex function $F(|q|^2)q$:

$C \mapsto C$. Considering the complex plane C as a two-dimensional linear space R^2 , the function $F(|q|^2)q$ is k times continuously differentiable, so that [15–17]

$$F(|q|^2)q \in \bigcup_{m,n=1}^{\infty} C^k((-n, n) \times (-m, m); R^2). \quad (2)$$

2.1. Perturbation Terms

The perturbed NLSE that is going to be studied in this paper is given by

$$iq_t + aq_{xx} + bF(|q|^2)q = -i\gamma q_{xxx} + \sigma q_{xxxx} + \psi q_{xxxxx} \quad (3)$$

Here, in (3), γ , σ and ψ represent the third, fourth and sixth order dispersion terms respectively. It is known that the NLSE, as given by (1), does not give correct prediction for pulse widths smaller than 1 picosecond. For example, in solid state solitary lasers, where pulses as short as 10 femtoseconds are generated, the approximation breaks down. Thus, quasi-monochromaticity is no longer valid and so higher order dispersion terms creep in. If the group velocity dispersion is close to zero, one needs to consider the third and higher order dispersion for performance enhancement along trans-oceanic and trans-continental distances. Also, for short pulse widths where group velocity dispersion changes, within the spectral bandwidth of the signal cannot be neglected, one needs to take into account the presence of higher order dispersion terms. This reasoning leads to the inclusion of the fourth and sixth order dispersion terms in addition to the third order dispersion terms [16, 17]. The effect of third and fourth order dispersion are simultaneously present in many practical cases. Roy et al. [25] pointed out that when the ratio of the third and fourth order dispersion is fixed to a certain value (e.g., $\gamma/\sigma = 10$), both of these perturbation terms contribute. In these situations the higher order dispersion terms have a pronounced effect especially for applications involving ultra-broadband optical source [25].

In this paper, (3) is going to be studied via HVP, for Kerr and power law nonlinearity. It needs to be noted that the NLSE has been studied with third and fourth order dispersions before. In fact, for the case of third order dispersion only, in a Kerr law medium, Equation (3) has been integrated by the aid of Lie symmetries [5, 6]. It must be noted that for the case of fourth order dispersion there has only been numerical studies for this problem [2]. In the case of the sixth order dispersion, it is only the application of soliton perturbation theory that had been achieved in 2008 [16]. This equation with sixth order

dispersion has not been studied from the integration point of view, until now. In fact, Equation (3), with a combination of all higher order dispersion terms both for Kerr and power law nonlinearities, is being integrated, by the aid of HVP, for the first time in this paper. Although Lie symmetry approach can be applied to integrate (3), at least for the Kerr law case, HVP method is immensely simpler as compared to that of Lie symmetry.

3. HE'S VARIATIONAL PRINCIPLE

In this section, HVP will be introduced. Subsequently, it will be applied to carry out the integration of (3) for Kerr and power laws of nonlinearity for F .

The starting point is the solitary wave ansatz that is given by

$$q(x, t) = g(s)e^{i\phi}, \quad (4)$$

where $g(s)$ represents the shape of the pulse and

$$s = x - vt, \quad (5)$$

$$\phi = -\kappa x + \omega t + \theta. \quad (6)$$

Here, v is the velocity of the soliton, κ is the frequency while ω is the soliton wave number and θ is the phase constant. Substituting this ansatz into (3) and decomposing into real and imaginary parts yields the following pair of relations, respectively

$$P_1g - bgF(g^2) - P_2g'' + P_3g^{(iv)} + \psi g^{(vi)} = 0 \quad (7)$$

$$Q_1g - Q_2g'' + Q_3g^{(iv)} = 0 \quad (8)$$

where the notations $g' = dg/ds$, $g'' = d^2g/ds^2$, $g^{(iv)} = d^4g/ds^4$ and $g^{(vi)} = d^6g/ds^6$ are used. Here, in (7) and (8),

$$P_1 = \omega + a\kappa^2 + \gamma\kappa^3 + \sigma\kappa^4 - \psi\kappa^6 \quad (9)$$

$$P_2 = a + 3\gamma\kappa + 6\sigma\kappa^2 - 15\psi\kappa^4 \quad (10)$$

$$P_3 = \sigma - 15\psi\kappa^2 \quad (11)$$

and

$$Q_1 = v + 2a\kappa + 3\gamma\kappa^2 + 4\sigma\kappa^3 - 6\psi\kappa^5 \quad (12)$$

$$Q_2 = \gamma + 4\sigma\kappa - 20\psi\kappa^3 \quad (13)$$

$$Q_3 = -6\psi\kappa \quad (14)$$

Integration of (8) yields

$$g(s) = \exp \left\{ -s \left[\frac{Q_2 - \sqrt{Q_2^2 - 4Q_1Q_3}}{2Q_3} \right]^{\frac{1}{2}} \right\} \quad (15)$$

that leads to the velocity (v) of the soliton.

Now, multiplying both sides of the real part Equation (7), by g' and integrating yields

$$P_1 g^2 - 2bgF(g^2) - P_2 (g')^2 - P_3 (g'')^2 + \psi(g''')^2 = K \quad (16)$$

where K is a constant and $g''' = d^3g/ds^3$. The stationary integral J is then defined as

$$J = \int_{-\infty}^{\infty} K ds = \int_{-\infty}^{\infty} \left[P_1 g^2 - 2bgF(g^2) - P_2 (g')^2 - P_3 (g'')^2 + \psi(g''')^2 \right] ds \quad (17)$$

Finally, the 1-soliton solution ansatz, given by

$$g(s) = Af \left[\frac{1}{\cosh(Bs)} \right], \quad (18)$$

is substituted into (17). Here, in (18), the parameters A and B represent the amplitude and inverse width of the soliton respectively, and the functional f depends on whether the nonlinear function F is Kerr or power. HVP states that the parameters A and B are determined from the solution of the equations [17, 32, 35]

$$\frac{\partial J}{\partial A} = 0 \quad (19)$$

and

$$\frac{\partial J}{\partial B} = 0. \quad (20)$$

The parameters A and B will now be determined for the following cases of nonlinearity in the following subsections. Finally, the velocity v of the soliton can be obtained after substituting (18) in the left hand side of (15) and then solving (15) for v which is located in Q_1 .

Now, to comment that this method is called semi-inverse variational principle it is J. H. He who first coined the terminology, for this method, in his Ph.D. thesis in Mechanical Engineering from Shanghai University in 1997 and this method was later published in 2004 [13]. Since that point onwards, this method is commonly referred to as He's semi-inverse variational principle.

3.1. Kerr Law

The Kerr law of nonlinearity originates from the fact that a light wave in an optical fiber faces nonlinear responses from non-harmonic motion of electrons bound in molecules, caused by an external electric field. Even though the nonlinear responses are extremely weak, their

effects appear in various ways over long distance of propagation that is measured in terms of light wavelength. The origin of nonlinear response is related to the non-harmonic motion of bound electrons under the influence of an applied field. As a result the induced polarization is not linear in the electric field, but involves higher order terms in electric field amplitude [16, 17, 35, 36].

In the case of Kerr law nonlinearity where $F(u) = u$, the perturbed NLSE is given by

$$iq_t + aq_{xx} + b|q|^2q = -i\gamma q_{xxx} + \sigma q_{xxxx} + \psi q_{xxxxx} \tag{21}$$

and therefore (7) reduces to

$$P_1g - bg^3 - P_2g'' + P_3g^{(iv)} + \psi g^{(vi)} = 0 \tag{22}$$

Thus, the stationary integral, from (17), is given by

$$J = \int_{-\infty}^{\infty} \left[P_1g^2 - \frac{b}{2}g^4 - P_2 \left(\frac{dg}{ds} \right)^2 - P_3 \left(\frac{d^2g}{ds^2} \right)^2 + \psi \left(\frac{d^3g}{ds^3} \right)^2 \right] ds \tag{23}$$

For Kerr law nonlinearity, the appropriate form of the soliton is given by

$$g(s) = \frac{A}{\cosh(Bs)} \tag{24}$$

and so J , from (23), simplifies to

$$J = 2P_1 \frac{A^2}{B} - \frac{2b}{3} \frac{A^4}{B} - \frac{2P_2}{3} A^2 B - \frac{14P_3}{15} A^2 B^3 + \frac{62\psi}{21} A^2 B^5 \tag{25}$$

The relations (19) and (20) gives the the relation between the soliton amplitude (A) and the inverse with (B) as

$$A = \left[\frac{155\psi B^6 - 49P_3 B^4 - 35P_2 B^2 + 105P_1}{70b} \right]^{\frac{1}{2}} \tag{26}$$

where the inverse width B is obtained from the algebraic equation

$$1705\psi B^6 - 441P_3 B^4 - 105P_2 B^2 - 105P_1 = 0 \tag{27}$$

whose solution is given by Cardano's method as

$$B = \left[\left(-\frac{3176523P_3^2}{495647765\psi^3} + \frac{3087P_2P_3}{1162810\psi^2} + \frac{21P_1}{682\psi} + \sqrt{D_1} \right)^{\frac{1}{3}} + \left(-\frac{3176523P_3^2}{495647765\psi^3} + \frac{3087P_2P_3}{1162810\psi^2} + \frac{21P_1}{682\psi} - \sqrt{D_1} \right)^{\frac{1}{3}} + \frac{147P_3}{1705\psi} \right]^{\frac{1}{2}} \tag{28}$$

with the discriminant D_1 given by

$$D_1 = - \left(\frac{21609P_3^2}{2907025\psi^2} + \frac{7P_2}{341} \right)^3 + \left(\frac{3176523P_3^2}{4956477625\psi^3} - \frac{3087P_2P_3}{1162810\psi^2} - \frac{21P_1}{682\psi} \right)^2 \quad (29)$$

Finally, the soliton amplitude A can be computed from (26).

The following figures show the numerical simulation of the optical soliton with Kerr law nonlinearity where the perturbation parameters are chosen as $\gamma = 0.014$, $\sigma = 0.012$ and $\psi = 0.001$. Figure 1(a) shows the comparison between the solutions between the variationally obtained solution and asymptotically obtained solution.

3.2. Power Law

This law of nonlinearity arises in nonlinear plasmas that solves the problem of small K -condensation in weak turbulence theory. It also arises in the context of nonlinear optics. Physically, various materials, including semiconductors, exhibit power law nonlinearities. Moreover highly nonlinear materials, such as semiconductor-doped glasses, have non-Kerr nonlinearity. Therefore, it is worthwhile investigating some cases where the increase in index is proportional to the field raised to the power different from two. When dealing with very broad optical

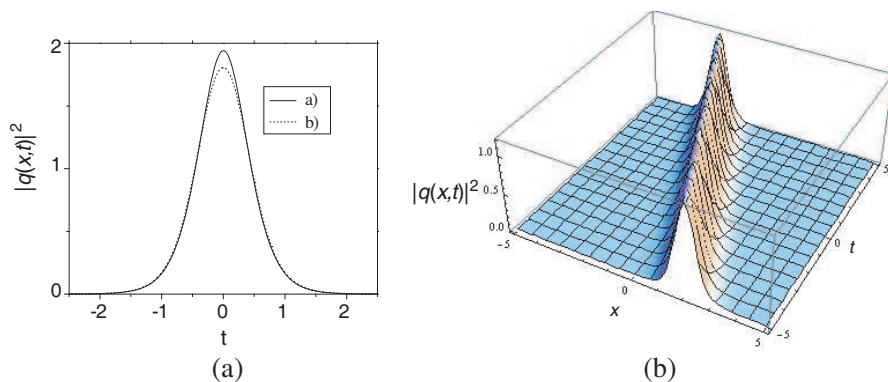

Figure 1. (a) Optical soliton with Kerr law nonlinearity a) numerical simulation of Equation (18), b) from He's variational approach, where the perturbation parameters are $t = 5$, $\gamma = 0.014$, $\sigma = 0.012$ and $\psi = 0.001$. (b) Numerical simulation of the optical soliton with Kerr law nonlinearity and parameters: $a = 0.2$, $b = 1$.

spectra (ultrashort optical pulses), dispersion up to fourth or even fifth and sixth order must be taken into account [2, 16, 17, 35, 36].

For the case of power law nonlinearity, where $F(u) = u^n$, the perturbed NLSE is given by

$$iq_t + aq_{xx} + b|q|^{2n}q = -i\gamma q_{xxx} + \sigma q_{xxxx} + \psi q_{xxxxx} \tag{30}$$

In (30), the parameter n dictates the power law parameter. The special case with $n = 1$ reduces to Kerr law nonlinearity. For power law nonlinearity, it is necessary to have $0 < n < 2$ to prevent wave collapse [1, 4, 5] and, in particular, $n \neq 2$ to avoid self-focusing singularity [4]. Thus, (7) reduces to

$$P_1g - bg^{2n+1} - P_2g'' + P_3g^{(iv)} + \psi g^{(vi)} = 0 \tag{31}$$

In this case, therefore, the stationary integral (17) is given by

$$J = \int_{-\infty}^{\infty} \left[P_1g^2 - \frac{b}{n+1}g^{2n+2} - P_2\left(\frac{dg}{ds}\right)^2 - P_3\left(\frac{d^2g}{ds^2}\right)^2 + \psi\left(\frac{d^3g}{ds^3}\right)^2 \right] ds \tag{32}$$

For power law nonlinearity, the hypothesis

$$g(s) = \frac{A}{\cosh^{\frac{1}{n}}(Bs)} \tag{33}$$

simplifies J to

$$J = \left[P_1\frac{A^2}{B} - \frac{2b}{(n+1)(n+2)}\frac{A^{2n+2}}{B} - P_2\frac{A^2B}{n(n+2)} + P_3G_1(n)A^2B^3 + \psi G_2(n)A^2B^5 \right] \frac{\Gamma(\frac{1}{n})\Gamma(\frac{1}{2})}{\Gamma(\frac{1}{n} + \frac{1}{2})} \tag{34}$$

where

$$G_1(n) = \frac{4n+3}{n^2(n+2)(3n+2)} \tag{35}$$

and

$$G_2(n) = \frac{1}{n^6(n+2)(3n+2)(5n+2)} \left\{ n(3n+2)(5n+2) + 4(n+1)^3(2n+1)^2(5n+2) - 8(n+1)^3(2n+1)^3 - 4(n+1)(2n+1)(3n+2)(5n+2) + 8(n+1)^2(2n+1)(5n+2) \right\} \tag{36}$$

The relations (19) and (20) when applied to (34) yields the amplitude of the soliton as

$$A = \left[\frac{n(n+2)P_1 - P_2B^2 + n(n+2)G_1(n)P_3B^4 + n(n+2)G_2(n)\psi B^6}{2nb} \right]^{\frac{1}{2n}} \tag{37}$$

where the inverse width, that is obtained from the algebraic equation $n(5n + 6)G_2(n)\psi B^6 + n(3n + 4)G_1(n)P_3B^4 + P_2B^2 - n^2P_1 = 0$ (38) whose solution is given by

$$\begin{aligned}
 B = & \left[\left\{ -\frac{1}{27} \left(\frac{(3n + 4)G_1(n)P_3}{(5n + 6)G_2(n)\psi} \right)^3 + \frac{(3n + 4)G_1(n)P_2P_3}{6n(5n + 6)^2G_2^2(n)\psi^2} \right. \right. \\
 & \left. \left. + \frac{nP_1}{2(5n + 6)G_2(n)\psi} + \sqrt{D_2} \right\}^{\frac{1}{3}} \right. \\
 & \left. + \left\{ -\frac{1}{27} \left(\frac{(3n + 4)G_1(n)P_3}{(5n + 6)G_2(n)\psi} \right)^3 + \frac{(3n + 4)G_1(n)P_2P_3}{6n(5n + 6)^2G_2^2(n)\psi^2} \right. \right. \\
 & \left. \left. + \frac{nP_1}{2(5n + 6)G_2(n)\psi} - \sqrt{D_2} \right\}^{\frac{1}{3}} - \frac{(3n + 4)G_1(n)P_3}{3(5n + 6)G_2(n)\psi} \right]^{\frac{1}{2}} \quad (39)
 \end{aligned}$$

and the discriminant D_2 is given by

$$\begin{aligned}
 D_2 = & - \left[\frac{1}{9} \left\{ \frac{(3n + 4)G_1(n)P_3}{(5n + 6)G_2(n)\psi} \right\}^2 - \frac{P_2}{3n(5n + 6)G_2(n)\psi} \right]^3 \\
 & + \left[\frac{1}{27} \left\{ \frac{(3n + 4)G_1(n)P_3}{(5n + 6)G_2(n)\psi} \right\}^3 - \frac{(3n + 4)G_1(n)P_2P_3}{6n(5n + 6)^2G_2^2(n)\psi^2} - \frac{nP_1}{2(5n + 6)G_2(n)\psi} \right]^2 \quad (40)
 \end{aligned}$$

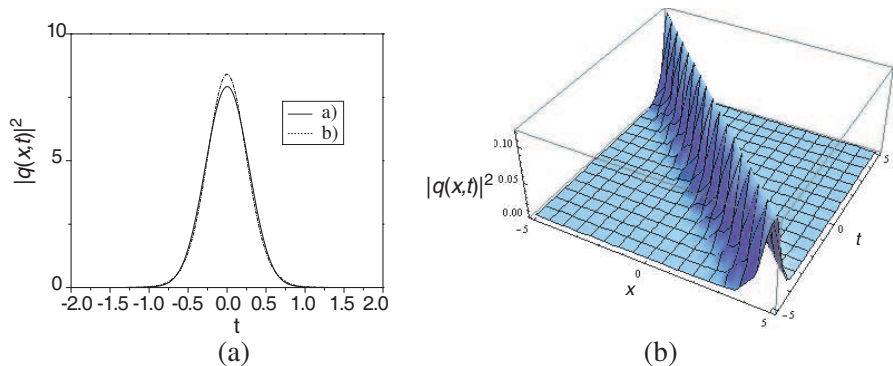

Figure 2. (a) Optical soliton with power law nonlinearity $n = 1/2$, a) numerical simulation of Eq. (18), b) from He’s variational approach, where the perturbation parameters are $t = 5$, $\gamma = 0.014$, $\sigma = 0.012$ and $\psi = 0.001$. (b) Numerical simulation of the optical soliton with power law nonlinearity where $n = 1/2$, $a = 0.5$, $b = 1$.

Subsequently, the soliton amplitude A is obtained from (37).

The following figure shows the numerical simulation of the optical soliton with power law nonlinearity where $n = 1/2$ and the perturbation parameters are chosen as $\gamma = 0.014$, $\sigma = 0.012$ and $\psi = 0.001$. Figure 2(a), shows the comparison between the solutions between the variationally obtained solution and asymptotically obtained solution.

4. CONCLUSION

In this paper, the HVP is used to carry out the integration of the NLSE with higher order dispersion terms. Both, Kerr law and power law nonlinearities are considered. After obtaining the 1-soliton solutions with these two kind of nonlinearities, the parameter domains are also identified for the soliton solution to exist. These results are from purely analytical standpoint and thus a closed form soliton solution has been obtained. The numerical simulations are also obtained.

ACKNOWLEDGMENT

The research work of the first (PDG) and fourth author (AB) was fully supported by NSF-CREST Grant No: HRD-0630388 and this support is genuinely and sincerely appreciated.

The first author is also extremely grateful to the third author (DAL) for helping her with this project that was assigned to her by her advisor, who is the fourth author (AB), towards the partial fulfillment of her doctoral studies. Besides this, DAL has absolutely no scientific contributions in this paper. The fourth author (AB) is also very thankful to the second author (DM) for doing all the numerical simulations in this paper, checking all the calculations and helping with addressing the referee's comments.

All four authors are extremely grateful to the anonymous referees as they helped to improve the original version of the manuscript, beyond measure.

REFERENCES

1. Ballav, M. and A. R. Chowdhury, "On a study of diffraction and dispersion-managed soliton in a cylindrical media," *Progress In Electromagnetics Research*, PIER 63, 33–50, 2006.
2. Banaee, M. G. and J. F. Young, "High-order soliton breakup and soliton self-frequency shifts in a microstructured optical fiber,"

- Journal of Optical Society of America B*, Vol. 23, No. 7, 1484–1489, 2006.
3. Banaei, H. A. and A. Rostami, “A novel proposal for passive all-optical demultiplexer for DWDM systems using 2-D photonic crystals,” *Journal of Electromagnetic Waves and Applications*, Vol. 22, No. 4, 471–482, 2008.
 4. Banerjee, A., “New approach to design digitally tunable optical filter system for wavelength selective switching based optical networks,” *Progress In Electromagnetics Research Letters*, Vol. 9, 93–100, 2009.
 5. Biswas, A., “Optical solitons: Quasi-stationarity versus Lie Transform,” *Optical and Quantum Electronics*, Vol. 35, No. 10, 979–998, 2003.
 6. Biswas, A. and S. Konar, *Introduction to Non-Kerr Law Optical Solitons*, CRC Press, Boca Raton, FL, USA, 2006.
 7. Biswas, A., R. Kohl, M. E. Edwards, and E. Zerrad, “Soliton parameter dynamics in a non-Kerr law media,” *Progress In Electromagnetics Research C*, Vol. 1, 1–35, 2008.
 8. Biswas, A., D. Milovic, and M. E. Edwards, *Mathematical Theory of Dispersion-managed Optical Solitons*, Springer Verlag, New York, NY, USA, 2010.
 9. Fu, Y., K. Li, and F. M. Kong, “Analysis of the optical transmission through the metal plate with slit array,” *Progress In Electromagnetics Research*, Vol. 82, 109–125, 2008.
 10. Ganji, D. D., H. Tari, and M. B. Jooybari, “Variational iteration method and homotopy perturbation method for nonlinear evolution equations,” *Computers and Mathematics with Applications*, Vol. 54, No. 7–8, 1018–1027, 2007.
 11. Ganji, Z. Z., D. D. Ganji, and A. Asgari, “Finding general and explicit solutions of high nonlinear equations by the exp-function method,” *Computers and Mathematics with Applications*, Vol. 58, No. 11–12, 2124–2130, 2009.
 12. Ganji, Z. Z., D. D. Ganji, and M. Esmailpour, “Study on nonlinear Jeffery-Hamel flow by He’s semi-analytical methods and comparison with numerical results,” *Computers and Mathematics with Applications*, Vol. 58, No. 11–12, 2107–2116, 2009.
 13. He, J. H., “Variational principles for some nonlinear partial differential equations with variable coefficients,” *Chaos, Solitons and Fractals*, Vol. 99, No. 4, 847–851, 2004.
 14. Heidari, A., S. F. Tayyari, and R. E. Sammelson, “An analytical approach to the stability of solitary solutions of cubic-quintic

- coupled non-linear Schrödinger's equations," *Communications in Nonlinear Science and Numerical Simulations*, Vol. 14, No. 9–10, 3554–3560, 2009.
15. Khalique, C. M. and A. Biswas, "Optical solitons with parabolic and dual power law nonlinearity via Lie symmetry analysis," *Journal of Electromagnetic Waves and Applications*, Vol. 23, No. 7, 963–973, 2009.
 16. Kohl, R., D. Milovic, E. Zerrad, and A. Biswas, "Optical soliton perturbation in a non-Kerr law media," *Optics and Laser Technology*, Vol. 40, No. 4, 647–662, 2008.
 17. Kohl, R., A. Biswas, D. Milovic, and E. Zerrad, "Optical solitons by He's variational principle in a non-Kerr law media," *Journal of Infrared, Millimeter and Terahertz Waves*, Vol. 30, No. 5, 526–537, 2009.
 18. Lv, X., B. Tian, T. Xu, K.-J. Cai, and W.-J. Liu, "Analytical study of the nonlinear Schrödinger equation with an arbitrary linear time-dependent potential in quasi-one-dimensional Bose-Einstein condensates," *Annals of Physics*, Vol. 323, No. 10, 2554–2565, 2008.
 19. Maurya, S. N., V. Singh, B. Prasad, and S. P. Ojha, "Modal analysis and waveguide dispersion of an optical waveguide having a cross-section of the shape of a cardioid," *Journal of Electromagnetic Waves and Applications*, Vol. 20, No. 8, 1021–1035, 2006.
 20. Medhekar, S., R. K. Sarkar, and P. P. Paltani, "Soliton pairing of two coaxially co-propagating mutually incoherent 1-D beams in Kerr type media," *Optica Applicata*, Vol. 37, No. 3, 243–259, 2007.
 21. Melamed, T., "Exact Gaussian beam expansion of time-harmonic electromagnetic waves," *Journal of Electromagnetic Waves and Applications*, Vol. 23, No. 8–9, 975–986, 2009.
 22. Mishra, M. and S. Konar, "High bit rate dense dispersion-managed optical communication systems with distributed amplification," *Progress In Electromagnetics Research*, PIER 78, 301–320, 2008.
 23. Panda, D. K. K., A. Chakraborty, and S. R. Choudhury, "Analysis of co-channel interference at waveguide joints using multiple cavity modelling technique," *Progress In Electromagnetics Research Letters*, Vol. 4, 91–98, 2008.
 24. Ramesh, M., D. Packiaraj, and A. T. Kalghatgi, "A compact branch line coupler using defected ground structure," *Journal of Electromagnetic Waves and Applications*, Vol. 22, No. 2–3, 267–

- 276, 2008.
25. Roy, S., S. K. Bhadra, and G. P. Agrawal, "Perturbation of higher order solitons by fourth-order dispersion in optical fibers," *Optics Communications*, Vol. 282, No. 18, 3798–3803, 2009.
 26. Sarma, A. K., "Soliton switching in a highly nonlinear dual-core holey fiber coupler," *Japanese Journal of Applied Physics*, Vol. 47, No. 7A, 5493–5495, 2008.
 27. Sarma, A. K., "Self-switching of solitons in an AlGaAs nanowire coupler," *Applied Optics*, Vol. 48, No. 27, 5067–5071, 2009.
 28. Sarma, A. K., "Dark soliton switching in an NLDC in the presence of higher-order perturbative effects," *Optics and Laser Technology*, Vol. 41, No. 3, 247–250, 2009.
 29. Sarma, A. K., "A comparative study of soliton switching in two and three core coupler with TOD and IMD," *Optik*, Vol. 120, No. 8, 390–394, 2009.
 30. Shahoei, H., H. Ghafoori-Fard, and A. Rostami, "A novel design methodology of multi-clad single mode optical fiber for broadband optical networks," *Progress In Electromagnetics Research*, Vol. 80, 253–275, 2008.
 31. Shwetanshumala, S., "Temporal solitons in nonlinear media modeled by modified complex Ginzburg Landau equation under collective variable approach," *International Journal of Theoretical Physics*, Vol. 48, No. 4, 1122–1131, 2009.
 32. Shwetanshumala, S., "Temporal solitons of modified complex Ginzburg-Landau Equation," *Progress In Electromagnetic Research Letters*, Vol. 3, 17–24, 2008.
 33. Siong, C. C. and P. K. Choudhury, "Propagation characteristics of tapered core helical clad dielectric optical fibers," *Journal of Electromagnetic Waves and Applications*, Vol. 23, No. 5–6, 663–674, 2009.
 34. Srivastava, S. K. and S. P. Ojha, "Photonic band gaps in one-dimensional metallic star waveguide structure," *Progress In Electromagnetics Research*, Vol. 84, 349–362, 2008.
 35. Topkara, E., D. Milovic, A. K. Sarma, F. Majid, and A. Biswas, "A study of optical solitons with Kerr and power law nonlinearities by He's variational principle," *Journal of European Optical Society*, Vol. 4, 09050, 2009.
 36. Topkara, E., D. Milovic, A. K. Sarma, E. Zerrad, and A. Biswas, "Optical solitons with non-Kerr law nonlinearity and inter-modal dispersion with time-dependent coefficients," *Communications in Nonlinear Science and Numerical Simulation*.

37. Tripathi, R., R. Gangwar, and N. Singh, "Reduction of crosstalk in wavelength division multiplexed fiber optic communication systems," *Progress In Electromagnetics Research*, PIER 77, 367–378, 2007.
38. Wang, Y.-L., W. Ren, and K. Li, "Exact transient field of a horizontal electric dipole excited by a Gaussian pulse on the surface of one dimensionally anisotropic medium," *Progress In Electromagnetics Research B*, Vol. 8, 307–318, 2008.
39. Wazwaz, A. M., "Exact solutions for the fourth order nonlinear Schrodinger equations with cubic and power law nonlinearities," *Mathematical and Computer Modelling*, Vol. 43, No. 7–8, 802–808, 2006.
40. Wazwaz, A. M., "A study on linear and nonlinear Schrödinger equations by the variational iteration method," *Chaos, Solitons and Fractals*, Vol. 37, No. 4, 1136–1142, 2008.