

FREQUENCY DOMAIN NLMS ALGORITHM FOR ENHANCED JAM RESISTANT GPS RECEIVER

A. Kundu and A. Chakrabarty

Kalpana Chawla Space Technology Cell
Department of Electronics & Electrical Communication Engineering
Indian Institute of Technology
Kharagpur-721302, West Bengal, India

Abstract—An optimal beamformer attempts to increase SNR at the array output by adapting its pattern to minimize some cost function. This is to say that, the cost function is inversely associated with the quality of the signal. Therefore by minimizing the cost function we can maximize signal at the array output. The primary optimal beamforming technique discussed in this paper will be MMSE, LMS, Frequency Domain LMS for GPS multipath reduction. In case of a GPS satellite, the DOA of the desired signal is mathematically known because the position of a satellite in an orbit is fixed at a particular time instant. So in some particular adaptive antenna algorithm the DOA of the desired signal is directly given as input.

1. INTRODUCTION

In the adaptive array processor shown in Fig. 1, the error signal is given as $e(t) = u(t) - w^H x(t)$, which is used to control the weights (w), where $u(t)$ is the desired signal. The weights are adjusted such that the mean squared error (MSE) between the array output and the reference signal is minimized. The expression for squared error is $e^2(t) = [u(t) - w^H x(t)]^2$. By taking expected value on both side of the equation we get, $E[e^2(t)] = E[u^2(t)] - 2w^H z + w^H R w$, where $z = E[x(t)u^*(t)]$ is the cross correlation between the reference signal and the array signal vector $x(t)$ and $R = E[x(t)x^H(t)]$ is the correlation matrix of the array output signal. $E[.]$ is the ensemble mean, this can be determined if signal statistics are known [13, 14]. The need for an adaptive beamforming algorithm solution is obvious, once we put a GPS receiver in a jamming environment is seldom constant in either terms of time or space, so the MMSE technique is not desirable to

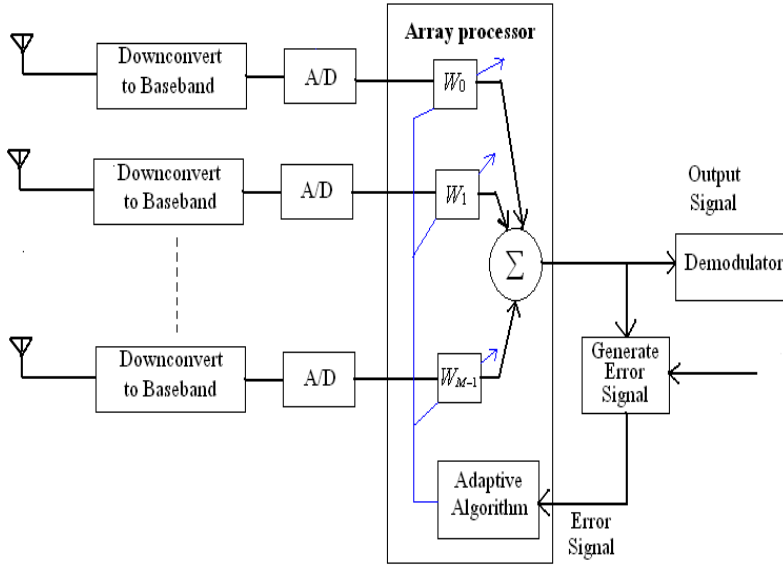

Figure 1. Adaptive array antenna with adaptive processor.

solve the normal equation directly. Since the DOA of the GPS signal & interferer signal both are time variable, the solution for weight vector must be updated. Furthermore, since the data required estimating the optimal solution is noisy, it is desirable to use an update equation, which uses previous solutions [6, 8, 11] for the weight vector to smooth the estimate of the optimal response, reducing the effect of interference.

LMS algorithm [7, 9, 16] is based on the steepest descent method, a well known optimization technique that recursively computes and updates the weight vectors. The weight vectors are updated iteratively by estimating the gradient of the quadratic error surface and then changing the weights in the direction opposite to the gradient by a small amount, as to minimize the MSE and to increase SNR. At time $t + 1$, the update value of the weight vector is given by $w(t + 1) = w(t) - \mu \nabla_w(E[e^2(t)])$, where $w(t + 1)$ denotes the new weights components at the $(t + 1)$ th iteration. μ is the positive step size that controls the rate of convergence that determines how close the estimated weights approach the optimal weights and $\nabla_w(E[e^2(t)])$ is an estimate of the gradient of MSE. The instantaneous estimate of the gradient vector is then given by $\nabla_w(E[e^2(t)]) = 2x(t)e^*(t)$ finally the update equation becomes, $w(t + 1) = w(t) - \mu x(t)e^*(t)$. Here the multiple 2 is absorbed by μ .

2. MODIFIED LMS ALGORITHM

The step size parameter μ governs the stability, convergence time and fluctuations of LMS adaptation process. One effective approach to overcome this dependence is to normalize the update step size with an estimate of the input signal variance $\sigma_u^2(t)$. Hence the weight update formula modified as

$$w(t + 1) = w(t) + \frac{\mu}{N\sigma_u^2(t)} x(t)e^*(t) \quad (1)$$

where N is the tap length of the spatial filter [12, 17]. This modification leads to the asymptotic performance of the number of taps N . hence convergence is strongly dependent on number of taps N . For large number of taps results is poorer i.e., poorer convergence rate. The use of active tap algorithm consistently improves the convergence rate of NLMS [1–3] algorithm.

3. FREQUENCY DOMAIN NLMS ALGORITHM

Figure 2 shows proposed frequency domain normalized LMS [4] algorithm with active tap detection. This scheme consists off two primary functions, firstly the adaptation process involving the update

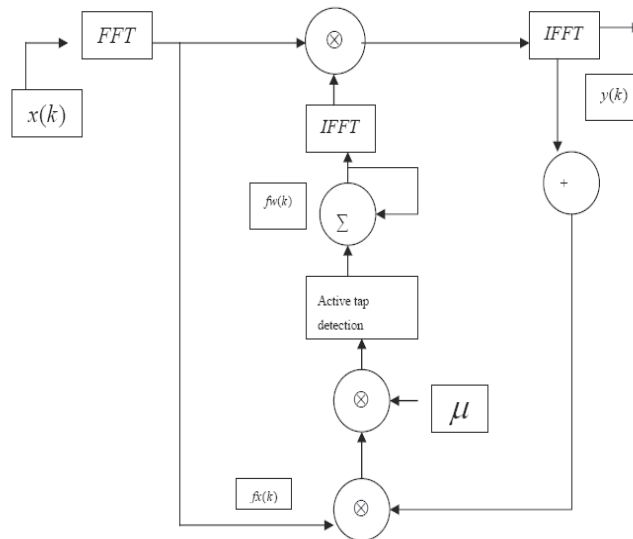

Figure 2. Signal flow in FDNLMS algorithm.

of the tap weights of the system and the second one the active tap detection which determine which tap are to be updated. Hence the update equation modifies to,

$$W(k+1) = W(k) + \frac{\mu X(k)e^*(k)}{N} \quad (2)$$

Here $e(k)$ is error waveform, $X(k)$ is the FFT of the received signal+noise. N is the number of taps. Error waveform is given by $e(k) = u(k) - x(k)w^H$. $u(k)$ is transmitted signal & $x(k)$ is the received signal+noise. Midst of large multipath & in the presence of multiple nearby intentional jammers NLMS algorithm suffers from poor convergence rate when number of taps is large, to rectify this problem the algorithm need to be slightly modified. We need to identify active and inactive regions within channel since elements of a smart antenna in the spatial domain correspond to different DOA's hence we prefer sparsely spaced elements. So accordingly the equation modifies as

$$W(k+1) = W(k) + \frac{\mu X(k)e^*(k)}{\sum_{j=1}^N A_j(k)} \quad (3)$$

$A_j(k)$ is the active tap and j is the tap number. If the tap is active $A_j = 1$, otherwise for an inactive tap $A_j = 0$. Now the active tap detection become important & it will be determined based on some intuition. Here we form an activity measure based upon the active taps corresponding to the desired signal. The channel is taken to be LTI. The signal received at an antenna element m is given by $x(k) = r(k) + nn(k)$ where $r(k)$ is the received signal and $nn(k)$ is noise at sampling instant k . Now we need to find the activity measure M considering that we are reducing undesired signals relative to the desired signal. Let define $\gamma = [\gamma_1, \gamma_2, \gamma_3, \dots, \gamma_N]$

and $\gamma = \sum_{k=1}^K u(k)x_j^*(k)$. By taking the discrete Fourier transform of γ across the collection of antenna elements we acquire vector Γ , $\Gamma = [\Gamma_1, \Gamma_2, \Gamma_3, \dots, \Gamma_N]$. The activity measure M for a spatial angle is finally given by $M = \Gamma(k)\Gamma^*(k)$ where Γ is the discrete Fourier transform of γ . In order to discriminate between the active and passive taps some threshold has to be modeled. Let define $T(k) =$

$\frac{2 \log(kN) \left[\sum_{i=1}^k X(i)X^*(i) \right] \left[\sum_{i=1}^k u(i)u^*(i) \right]}{KN}$ as threshold. Therefore $j+1$ th tap at the sampling instant k is active if $M > \alpha T(k)$, α is an integer from 0 to 1, which serves as control for the threshold spread.

4. SIMULATED RESULT

Here we have used MatlabTM 7 as simulation platform. μ set as .008; 640 input signal samples of training sequence have signed value of 1 or -1 to simulate a transmitter sending binary values. $f_c = 1575$ MHz L_1 frequency. Hence $\lambda = .19$ m; to avoid the grating lobes we take $d = \lambda/2 = .095$ m. Propagation delay from transmitter to receiver 1st antenna element is set as 70 ms. The performance of the frequency domain NLMS is examined in terms of convergence rates, number of active taps used and beam pattern. In order to create a realistic environment we have taken more than one multipath with different gain with both amplitude and phase components. Three DOA's $60^\circ, 30^\circ, -20^\circ$ transmitted towards GPS receiver & each multipath [5] arrives at the antenna system with a difference of one sampling period $1/f_c$, so we can denote the signal arrives at antenna of a GPS receiver at time instant $u(t), u(t-1), u(t-2) \dots$. The corresponding gains introduced to multipath have .5, .66, 1.0 amplitudes respectively. Three different weight vectors of frequency domain normalized LMS equations were used in processing the multipath simulation conducted for threshold control α values of .1, .5, 1.0. Here we show the convergence rate of each multipath in a tabular form referred to Table 1 & in terms of the number of samples required to reach steady state. From Table 2 it is quite clear a narrower threshold leads to less taps being adapted, this comes as a cost of delay.

Table 1. Convergence rate for three multipaths.

Adaptive Algorithm	No. of Samples		No. of Samples		No. of Samples	
	1 st Multipath		2 nd Multipath		3 rd Multipath	
	Delay	steady state	Delay	steady state	Delay	steady state
LMS	0	50	0	40	0	40
FDNLMS						
$\alpha = .1$	0	40	0	20	0	40
$\alpha = .5$	54	90	27	45	26	60
$\alpha = 1.0$	120	150	60	85	60	90

Table 2. No of taps adapted.

Adaptive Algorithm	No.of Taps Adapted	No.of Taps Adapted	No.of Taps Adapted	No.of Taps Adapted
		1 st Multipath	2 nd Multipath	3 rd Multipath
LMS		32	32	32
FDNLMS	$\alpha = .1$	2	1	8
	$\alpha = .5$	1	1	4
	$\alpha = 1.0$	1	1	2

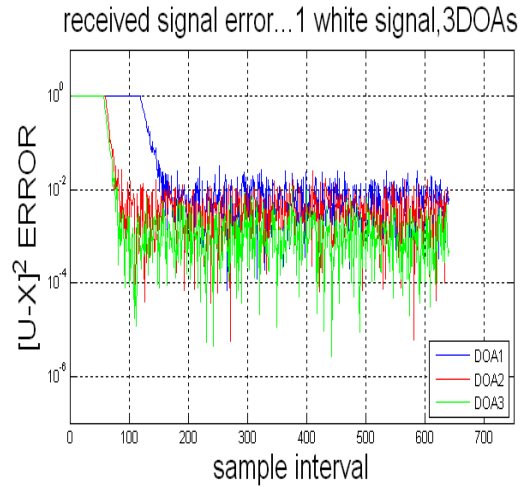
**Figure 3.** Received Signal error & convergence for FDNLMS.

5. DISCUSSION

The mean square error lies at approximately .005, .0015, .00034 for each multipath respectively after it converges. Results show an overall increase in convergence rate of approximately 15% compared to standard LMS algorithm from simulated results referred Fig. 3. α values of .5 & 1.0, results in a dramatic increase in convergence rate,

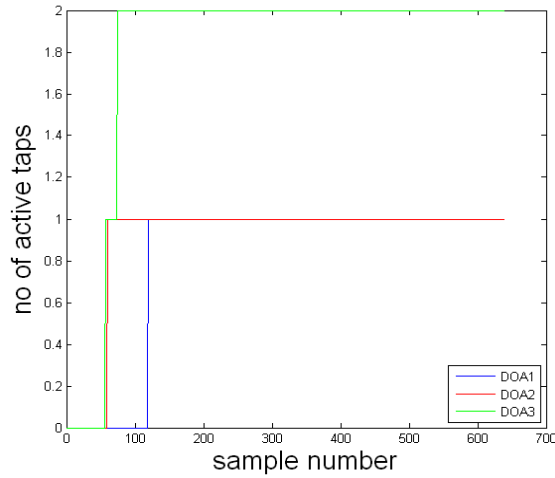

Figure 4. DNLMS active number of taps for $\alpha = .1$.

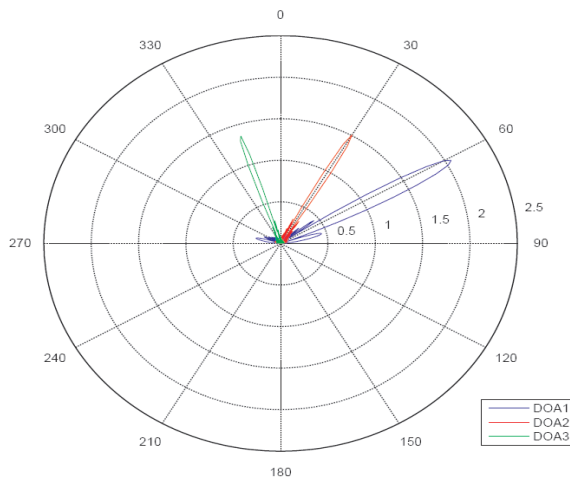

Figure 5. FDNLMS $\alpha = .1$ beam pattern for 2 multipath with 1 DOA of desired signal.

this is due to large delay period as a result of narrow threshold level. The narrow threshold gives us the ability to adapt with limited number of taps. In the Fig. 4 we show the number of taps being adapted for FDNLMS. Adaptive antenna with FDNLMS algorithm showed capability to steer beam in multiple direction of

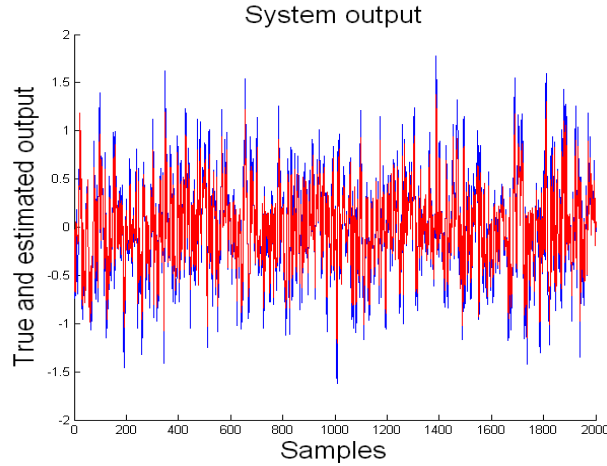

Figure 6. True & estimated output GPS data signal after demodulation.

DOA's [8, 10, 17, 18] and place nulls towards interferers the gain of each beam is the inverse of the gain introduced to each corresponding multipath shown in Fig. 5. Multipath is the dominant error source in high precision-based GPS applications and is also a significant error source in non-differential applications. Many receiver architectures have been on the market and claim various multipath mitigation characteristics. Most of these techniques can be characterized either as discriminator function shaping or correlation function shaping. In this study, Frequency domain NLMS adaptive filter method is applied in multipath mitigation for GPS application. A simplified GPS plus multipath signal model [15, 16, 18] in MATLAB environment is utilized in this simulation. This approach improves the performance of the adaptive spatial filter compared with other methods. Results referred in Fig. 6 shows the true & estimated GPS data after demodulation. Simulation results also show that the proposed method is a viable solution to increase the SNR in the presence of a short delay multipath environment. The combined characteristic of this study prevails over those of other techniques available presently. In addition, the prerequisite of short delay multipath causes the influences of hardware complexity in the FDNLMS adaptive filter to be insignificant. Therefore, the proposed method is a well-suited and well-balanced application in multipath mitigation [11, 16, 19].

REFERENCES

1. Homer, J., I. Mareels, and C. Hoang, "Enhanced detection-guided NLMS estimation of sparse FIR-modeled signal channels," *IEEE Transactions on Circuits and Systems I: Regular Papers*, Vol. 53, Issue 8, 1783–1791, Aug. 2006.
2. Homer, J., "Detection guided NLMS estimation of sparsely parametrized channels," *IEEE Transactions on Circuits and Systems II: Analog and Digital Signal Processing*, Vol. 47, Issue 12, 1437–1442, Dec. 2000.
3. Bellofiore, S., J. Foutz, R. Govindarajula, I. Bahceci, C. A. Balanis, A. S. Spanias, J. M. Capone, and T. M. Duman, "Smart antenna system analysis, integration and performance for mobile ad-hoc networks (MANETs)," *IEEE Transactions on Antennas and Propagation*, Vol. 50, Issue 5, 571–581, May 2002.
4. Farhang-Boroujeny, B. and K. S. Chan, "Analysis of the frequency-domain block LMS algorithm," *IEEE Transaction on Signal Processing*, Vol. 48, Issue 8, 2332–2342, Aug. 2000.
5. Braasch, M. S., "GPS multipath model validation," *Position Location and Navigation Symposium, 1996, IEEE*, 672–678, April 22–26, 1996.
6. Rocca, P., L. Manica, and A. Massa, "An effective excitation matching method for the synthesis of optimal compromises between sum and difference patterns in planar arrays," *Progress In Electromagnetics Research B*, Vol. 3, 115–130, 2008.
7. Kazemi, S., H. R. Hassani, G. Dadashzadeh, and F. Geran, "Performance improvement in amplitude synthesis of unequally spaced array using least mean square method," *Progress In Electromagnetics Research B*, Vol. 1, 135–145, 2008.
8. Lizzi, L., F. Viani, M. Benedetti, P. Rocca, and A. Massa, "The M-DSO-ESPRIT method for maximum likelihood Doa estimation," *Progress In Electromagnetics Research*, PIER 80, 477–497, 2008.
9. Cengiz, Y. and H. Tokat, "Linear antenna array design with use of genetic, memetic and tabu search optimization algorithms," *Progress In Electromagnetics Research C*, Vol. 1, 63–72, 2008.
10. Gu, Y.-J., Z.-G. Shi, K. S. Chen, and Y. Li, "Robust adaptive beamforming for steering vector uncertainties based on equivalent DOAs method," *Progress In Electromagnetics Research*, PIER 79, 277–290, 2008.
11. Guney, K. and S. Basbug, "Interference suppression of linear antenna arrays by amplitude-only control using a bacterial foraging algorithm," *Progress In Electromagnetics Research*,

- PIER 79, 475–497, 2008.
12. Xue, W. and X.-W. Sun, “Multiple targets detection method based on binary Hough transform and adaptive time-frequency filtering,” *Progress In Electromagnetics Research*, PIER 74, 309–317, 2007.
 13. Mahmoud, K. R., M. El-Adawy, S. M. M. Ibrahim, R. Bansal, and S. H. Zainud-Deen, “A comparison between circular and hexagonal array geometries for smart antenna systems using particle swarm optimization algorithm,” *Progress In Electromagnetics Research*, PIER 72, 75–90, 2007.
 14. Guney, K. and M. Onay, “Amplitude-only pattern nulling of linear antenna arrays with the use of bees algorithm,” *Progress In Electromagnetics Research*, PIER 70, 21–36, 2007.
 15. Gozasht, F., G. Dadashzadeh, and S. Nikmhr, “A comprehensive performance study of circular and hexagonal array geometries in the LMS algorithm for smart antenna applications,” *Progress In Electromagnetics Research*, PIER 68, 281–296, 2007.
 16. Mukhopadhyay, M., B. K. Sarkar, and A. Chakrabarty, “Augmentation of anti-jam GPS system using smart antenna with a simple DOA estimation algorithm,” *Progress In Electromagnetics Research*, PIER 67, 231–249, 2007.
 17. Mouhamadou, M., P. Vaudon, and M. Rammal, “Smart antenna array patterns synthesis: Null steering and multi-user beamforming by phase control,” *Progress In Electromagnetics Research*, PIER 60, 95–106, 2006.
 18. Sanyal, S. K., Q. M. Alfred, and T. Chakravarty, “A novel beam-switching algorithm for programmable phased array antenna,” *Progress In Electromagnetics Research*, PIER 60, 187–196, 2006.
 19. Mouhamadou, M., P. Armand, P. Vaudon, and M. Rammal, “Interference suppression of the linear antenna arrays controlled by phase with use of SQP algorithm,” *Progress In Electromagnetics Research*, PIER 59, 251–265, 2006.