

DESIGN FOR PCS ANTENNA BASED ON WIBRO-MIMO

K.-S. Min, M.-S. Kim, C.-K. Park, and M. D. Vu

Radio Sciences and Engineering
Korea Maritime University
Korea

Abstract—This paper presents a design of wireless broadband (WiBro)-multi-input multi-output (MIMO) and personal communication service (PCS) antenna for practical mobile phone. To decrease the mutual coupling of WiBro-MIMO antenna, it is considered on the projected ground structure. In addition, two type PCS antennas for multi-function mobile phone are designed. The proposed antennas are well resonated in each operating frequency band. The measured bandwidths of 3-dimensional (3D) and 2-dimensional (2D) PCS antennas are 110 MHz and 130 MHz below -10 dB, respectively. The isolations between WiBro-MIMO and two PCS antenna are below -15 dB by 2D antenna type and -20 dB by 3D antenna type, respectively. The printed IFA has shown a better performance than modified planner IFA with spiral and shorting strip.

1. INTRODUCTION

A multi-input multi-output (MIMO) antenna system is a well-known technique to enhance the performance of wireless communication systems. Channel capacity of a MIMO antenna system is much larger than that provided by the conventional wireless system [1, 2]. In order to create a MIMO antenna system on wireless handy device, two or more antenna elements could be placed in a very small space. Due to the complex and narrow structure in the mobile handy terminals, the space which is allowed for antenna is extremely restricted. Thus, in case of a MIMO antenna in mobile handy terminal, the mutual coupling including radiation pattern coupling between closely arrayed antenna elements causes the decrease of a MIMO antenna performance. It means that we must consider not only the antenna size but also the

suitable antenna array method to design the MIMO antenna system for mobile handy terminal.

In this research, a 2-channel wireless broadband (WiBro)-MIMO antenna and 1-channel personal communication service (PCS) band antenna are designed for internal type of mobile phone. The antenna elements are employed the planner spiral antenna with shorting strip line antenna and the printed inverted F antenna (IFA), due to its compact size and simple fabrication. All PCS antennas are designed based on modified ground structure for high isolation characteristics.

2. WIBRO-MIMO AND PCS BAND ANTENNA

Figure 1 shows the 3-dimension (3D) PCS band antenna with the 2-channel WiBro-MIMO antenna band [3]. The antenna for PCS is designed planar spiral antenna with shorting strip line between two WiBro antenna elements. That structure is considered by conventional planner IFA based. The proposed antenna is designed of 3D structure on the ground between 2-channel WiBro-MIMO antennas. The antenna used an air space to increase the isolation and bent microstrip line like a spiral turned to inner for good isolation in PCS frequency band. Fig. 1(b) shows the antenna structure for PCS band. As shown in the Fig. 1(b), the PCS antenna structure is considered for increase of isolation characteristics. The slit is applied to expand the physical electric length of antenna as shown Fig. 1(b). An air space

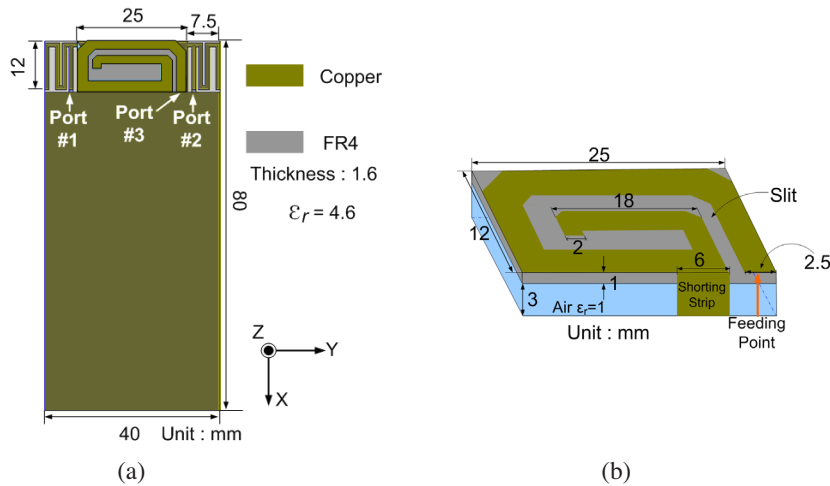

Figure 1. Proposed 3D PCS antenna configuration, (a) whole antenna configuration, (b) configuration of 3D PCS band antenna.

is employed between PCS band WiBro antennas for good return loss and bandwidth. We examined return loss of PCS antenna with various height of the space. Finally, we decided to 3 mm height because it has a good return loss.

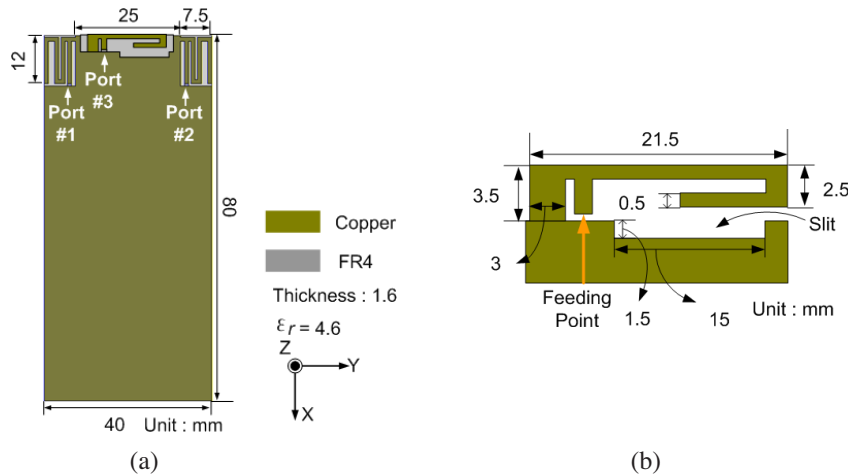

Figure 2. Proposed 2D PCS antenna configuration, (a) whole antenna configuration, (b) configuration of 2D PCS band antenna.

Figure 2(a) shows a multi-band antenna configuration which includes the PCS band antenna with a 2-channel WiBro-MIMO antenna band. As shown Fig. 1(b), the proposed antenna has a volume, thus, it is named a 3D PCS antenna. It is designed the printed IFA between two WiBro antenna elements. This antenna is located within a plan, therefore, it is named 2D PCS antenna. Due to the restricted space, it is used a bent microstrip line for good return loss at operating frequency band. Generally, the bandwidth of an IFA antenna is determined by the distance between antenna and ground plane. However, in this design, the distance between antenna and ground plane of the IFA antenna is reduced because of the bent line. Thus, it is used a slit on the ground plane to increase the distance between antenna and ground plane of the IFA antenna. Fig. 2(b) shows the IFA for PCS band. As shown in the Fig. 2(b), there is a slit on the ground plane of the IFA for the wide bandwidth of the IFA. In this antenna structure, the antenna bandwidth is determined by the slit height. We examined the antenna bandwidth with various height of the slit and determined with 1.5 mm because it has a good bandwidth.

Figure 3(a) shows the calculated S-parameters of the proposed 3D PCS and WiBro-MIMO antenna. The proposed antenna is well

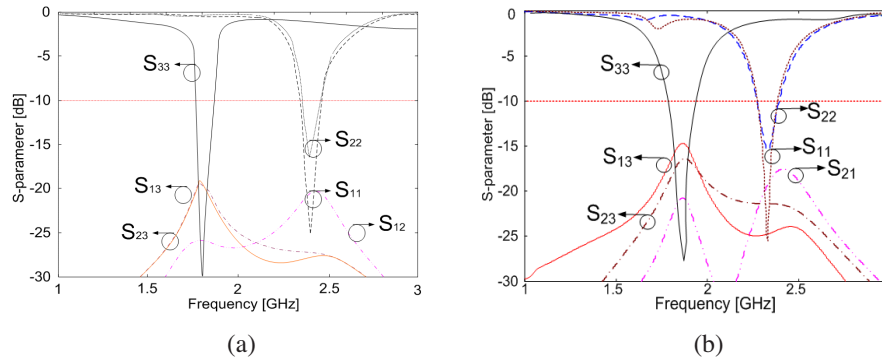

Figure 3. The calculated S-parameters of the proposed antenna, (a) 3D PCS and WiBro-MIMO antenna, (b) 2D PCS and WiBro-MIMO antenna.

resonated in the PCS and WiBro bands, respectively. The bandwidth of PCS antenna has about 140 MHz which requiring on PCS system. On the other hand, because the isolation between two frequency bands is high, the WiBro antenna characteristic is not much affected by the PCS antenna. The mutual couplings between three antennas are calculated maximum -15 dB below at all frequency bands. Fig. 3(b) shows calculated results of the proposed 2D PCS antenna. The bandwidth of antenna for PCS band is 110 MHz. The 2-channel WiBro antenna is operated at 2.35 GHz. On the other hand, because the isolation between two frequencies bands has a good performance, the WiBro antenna characteristic is not much affected by the PCS antenna. The mutual couplings between three antennas are calculated maximum -20 dB below at all frequency bands. The mutual coupling of 2D PCS antenna is lower than that of 3D PCS antenna. However, that performance shows still good isolation characteristics and the bandwidth is also larger 30 MHz than 3D PCS antenna's one.

Figure 4 shows the calculated radiation patterns of two proposed PCS antennas. The solid line shows the YZ-plane (H-plane) of the antenna, and it also shows the typical H-plane radiation pattern of the IFA. However, it is tilted to Y direction because the bent of microstrip line leans to the Y direction. The dotted line shows the XY-plane (E-plane) radiation pattern of the antenna, it also shows the typical E-plane radiation pattern of the IFA. Due to the reflection of the PCB board, the main beam of the E-plane is toward to 0 degree. Even though the bent of microstrip line and PCB board effect to the antenna radiation patterns, the PCS band antenna shows a good radiation pattern for communication.

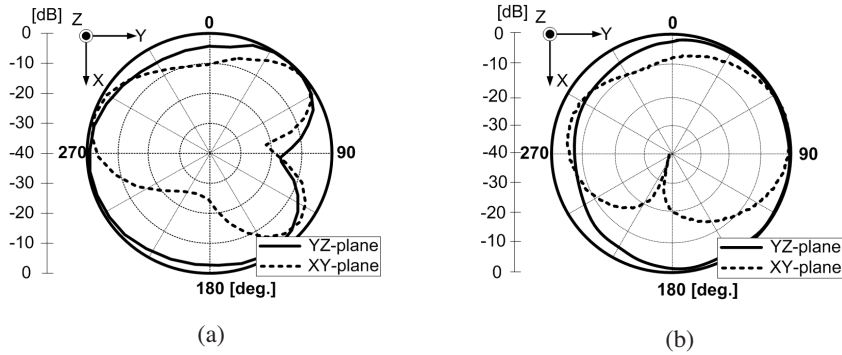

Figure 4. Calculated radiation patterns of PCS band antenna at 1.8 GHz, (a) 3D PCS band antenna, (b) 2D PCS band antenna.

Figure 5 shows the photographs of the proposed antenna for the 2-channel WiBro-MIMO antenna with the PCS antenna. The PCS band antennas are designed using the 2D printed IFA and 3D modified IFA between two WiBro antenna elements.

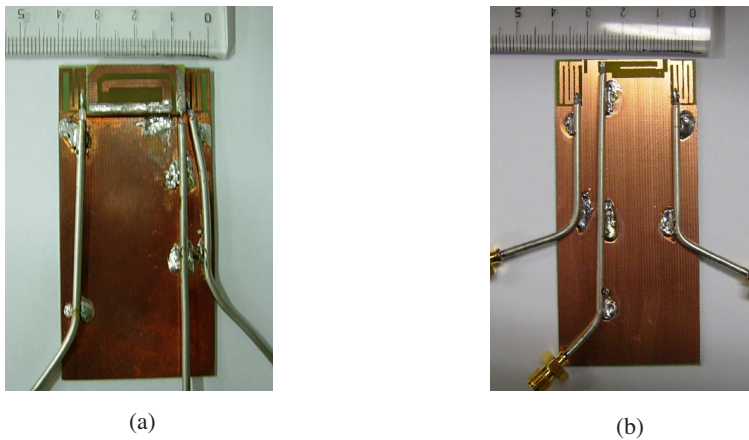

Figure 5. Photograph of proposed antennas, (a) with 3D PCS antenna, (b) with 2D PCS antenna.

Figure 6 shows the measured S-parameters of the fabricated multi-channel antenna. As shown in the Fig. 6, the measured S-parameters of the fabricated antenna are shown the good agreement comparing with the calculated results on Fig. 3. Only due to the effect of the

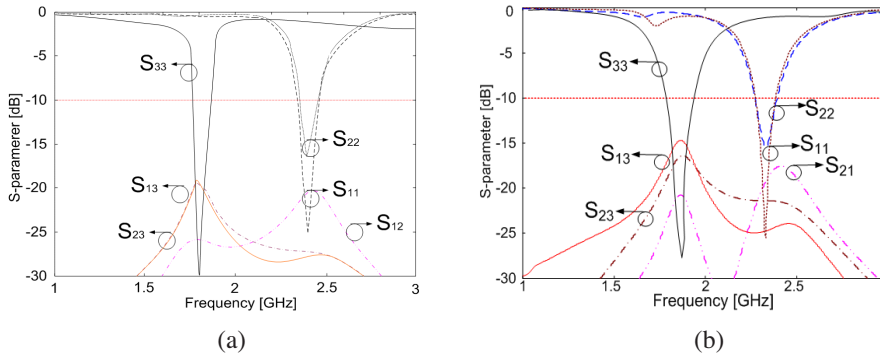

Figure 6. The measured S-parameters of the proposed antenna, (a) 3D PCS and WiBro-MIMO antenna, (b) 2D PCS and WiBro-MIMO antenna.

connector and coaxial cables of the each antenna for feeding, antenna bandwidth of 2D PCS antenna reduced about 10 MHz. However, it still satisfies the bandwidth requiring in PCS communication.

Figure 7 and Fig. 8 show the measured radiation patterns of the fabricated PCS band antenna and the 2-channel WiBro antenna, respectively. They show the reasonable agreement comparing with calculated ones. The back lobes in Figs. 7(a) and (b) are considered by the effect of the connector and the coaxial cables. Additionally, made lobes to X-direction in Fig. 7(a) is considered by the effect of cable near the shorting-strip line. As shown in Fig. 8, we confirm that the proposed two PCS antenna is not affected to radiation pattern of 2-channel WiBro-MIMO antennas.

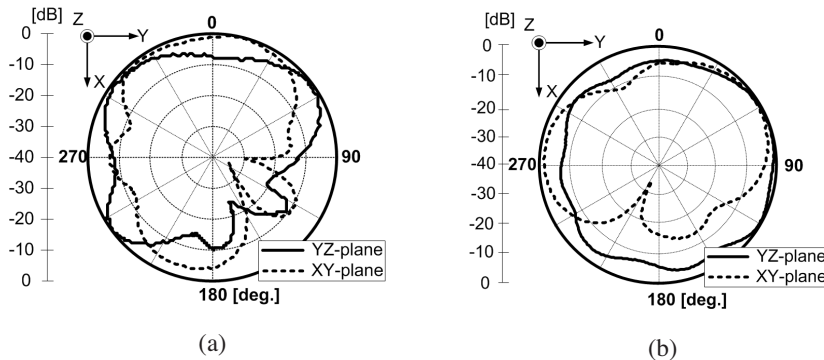

Figure 7. The measured radiation patterns at 1.8 GHz, (a) 3D PCS antenna, (b) 2D PCS antenna.

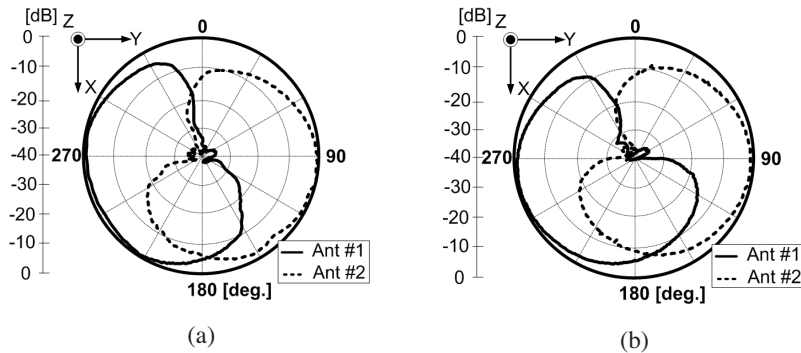

Figure 8. The measured radiation patterns of the WiBro antennas, (a) 2-channel WiBro-MIMO antenna with 3D PCS, (b) 2-channel WiBro-MIMO antenna with 2D PCS.

3. CONCLUSION

A compact WiBro-MIMO and two type PCS antenna are proposed. The isolation between each WiBro-MIMO antenna elements is considered using projected ground structure. The S-parameters and radiation patterns are examined and they show reasonable agreements with the simulated results. The characteristics of proposed PCS antennas are satisfied the Korean PCS operating frequency band. The measured bandwidth of 3D and 2D PCS antenna are 110 MHz and 130 MHz, respectively. The isolations between WiBro-MIMO and two PCS antenna are below -15 dB by 2D type and -20 dB by 3D type antenna, respectively. The printed IFA has shown a better performance than modified planner IFA with spiral and shorting strip.

REFERENCES

1. Foschini, G. J. and M. J. Gans, "On limits of wireless communications in a fading environment when using multiple antennas," *Wireless Personal Comm.*, Vol. 6, No. 3, 311–335, March 1998.
2. Shiu, D.-S., G. J. Foschini, M. J. Gans, and J. M. Kahn, "Fading correlation and its effect on the capacity of multielement antenna systems," *IEEE Trans. on Comm.*, Vol. 48, No. 3, 502–513, Mar. 2000.
3. Kim, D.-J. and K.-S. Min, "Compact 2-channel MIMO antenna for WiBro handy terminal application," *APMC 2006*, Vol. 3, 214–217, Dec. 2006.