

DESIGN OF A COMPACT UWB ANTENNA INTEGRATED WITH GSM/WCDMA/WLAN BANDS

Guihong Li*, Huiqing Zhai, Tong Li, Xiaoyan Ma, and Changhong Liang

National Laboratory of Science and Technology on Antennas and Microwaves, Xidian University, Xi'an, Shanxi 710071, China

Abstract—In this research, a compact printed antenna design operating on ultra-wideband (UWB) and three extra wireless communication bands is proposed. An ellipse-shaped monopole is utilized to realize UWB application (3.1–10.6 GHz). The modified ground employs three folded Capacitive Loaded Line Resonators (CLLRs) to obtain triple relatively lower communication bands, including parts of global System for Mobile Communications (GSM) band at the centre frequency of 1.78 GHz, Wideband Code Division Multiple Access (WCDMA) band at the centre frequency of 2.15 GHz, and Wireless Local Area Networks (WLAN) band at the centre frequency of 2.4 GHz. The CLLRs are designed with quarter-wavelength to control the corresponding frequencies independently. Good agreement is achieved between the simulation and measurement to verify our presented design. The basic, dual-, triple-band UWB antennas are also simulated and good results are obtained. Small group delay variations across UWB frequencies are obtained for the presented antenna and reference antennas, with some level of distortion observed.

1. INTRODUCTION

Since the Federal Communications Commission (FCC) specifies the unlicensed 3.1–10.6 GHz band for UWB commercial usages in 2002, the increasing demands have stimulated many researches into UWB antenna designs, such as [1–6]. Antenna designs for UWB applications are facing many challenges including their impedance matching, radiation stability, and electromagnetic interference (EMI) problems, especially the compact size design. Nowadays, the requirement of a

Received 6 December 2012, Accepted 15 January 2013, Scheduled 20 January 2013

* Corresponding author: Guihong Li (guihongli@sina.com).

compact single antenna operating on multi wireless radiation bands including UWB range is increasing due to the advantages of large channel capacity, small size, and easy integration. Nonetheless, only a few papers have been reported to focus the integration of the UWB band and other available wireless communication bands. In [7, 8], an L-shaped resonant element and a fork-shaped monopole were employed to integrate the Bluetooth band with the existing UWB operation, respectively. However, three or more integrated bands are difficult to produce due to the strong coupling between different resonant elements. How to create multi bands integrated with UWB is becoming a challenging and attractive topic. Several methods have been proposed to satisfy the requirement. For example, a multi-band antenna was achieved by inserting a notched region and adding narrow quarter-wavelength strips to the middle part of diamonded shaped UWB antenna in [9]. In [10], a CPW structure with three symmetrical U-shaped strips was utilized to achieve triple-band UWB performance. In [11], a compact multi-band antenna covering Bluetooth, WiMAX, WLAN, and ITU standards frequency bands was proposed by adding three stubs to the coplanar waveguide (CPW) structure, but the antenna did not cover the whole UWB range.

Nowadays, GSM system has found wide application in mobile and portable wireless communications due to its great network capability and good stability. GSM system contains GSM850, GSM 900, GSM 1800, and GSM 1900. Among them, GSM 900 and GSM 1800 are used most frequently. GSM 1800 has emerged later than GSM 900, but has the stronger piercing force and weaker transmitting power, suitable for the urban applications. WCDMA is selected as the third generation (3G) of wireless communication technique inheriting GSM technique. WCDMA can provide the higher data rate of voice, image, data, and video communication for the mobile terminal device. Until now, WCDMA has become the main 3G standard in most country and area, which has the richest terminal classes. Besides, WCDMA can be completely compatible with GSM. Additionally, WLAN is based on IEEE802.11 standard, including WLAN 2.4 GHz and WLAN 5.8 GHz radio wavebands. WLAN can applied in the family and enterprise to access internet. Therefore, GSM 1800/WCDMA/WLAN wavebands have their own practical backgrounds in industry, especially in personal mobile and portable wireless applications.

In this research, a novel compact UWB antenna design with three extra controllable bands is proposed. The research utilizes an ellipse-shaped monopole antenna covering UWB operation as preference. By adding quarter-wavelength meandered Capacitive Loaded Line Resonators (CLLRs) on the edge of partial ground plane, triple

lower radiation bands at the centre frequency of 1.78 GHz, 2.15 GHz, and 2.4 GHz are generated, which are parts of GSM, WCDMA, and WLAN bands. Since a 50-Ohm feed line connected to an impedance transformer and three stepped slits etched in the ground are adopted, the matching of the proposed antenna is improved effectively. Meanwhile, the radiator is biased to avoid the waste of space and realize miniaturization further. The employment of CLLRs to the basic ellipse-shaped monopole can simplify and flexibly add the extra resonant frequencies while keeping the UWB property. The presented design principles of the multi-operation mechanism can be also applied to other multi-band UWB antennas.

2. ANTENNA DESIGN AND ANALYSIS

2.1. Antenna Design Procedure

Figure 1 shows the geometries of the proposed UWB antenna based on an ellipse monopole. The antenna is fabricated on a FR4 substrate with a relative permittivity $\epsilon_r = 4.4$. To achieve the desired extra triple bands, a ground plane with three CLLRs deposited at the same side of the feed line are introduced. Here, the CLLRs have the widths and gaps of 0.5 mm, with little influence on the resonant operation. The lengths are $20 + 2.5 + 11 + 1.5 + 3 = 38$ mm for GSM band, $20 + 1.5 + 2 = 23.5$ mm for WCDMA band, 19.5 mm for WLAN band. The lengths are approximately $\lambda_g/4$ for the corresponding resonance. λ_g can be determined by $\lambda_g = c/[f(\epsilon_{eff})^{1/2}]$, $\epsilon_{eff} = (\epsilon_r + 1)/2$, in

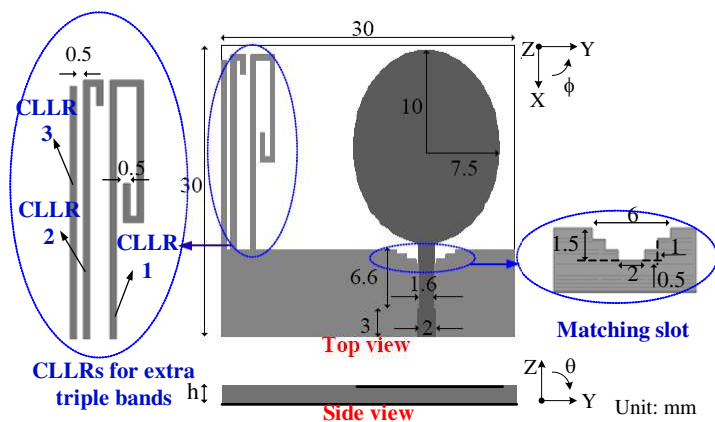

Figure 1. Geometries of the proposed antenna.

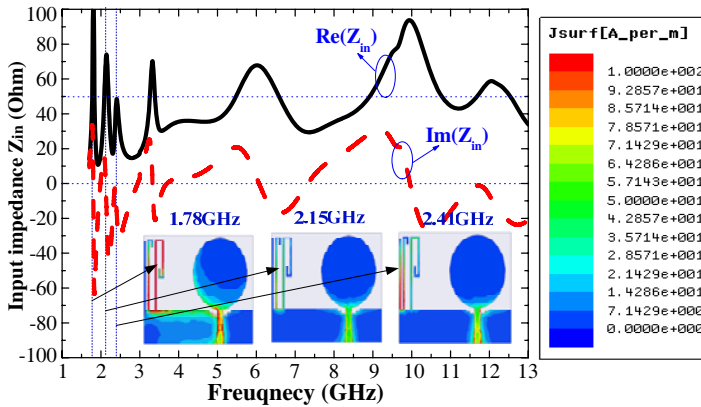

Figure 2. The simulated input impedance results of the proposed antenna.

which ε_{eff} and ε_r are effective permittivity and relative permittivity of substrate, c is velocity of light, and f is resonant frequency. It is noteworthy that CLLR 1 is designed a little longer than $\lambda_g/4$ for GSM band in order to reduce the coupling between monopole and CLLRs. The ellipse patch biases 6mm apart from the centre of antenna to provide more space for CLLRs and realize compact antenna dimensions, $30 \times 30 \times 1 \text{ mm}^3$ in physical size. That is to say, the design adds extra lower frequency bands into UWB antenna without increasing the overall size. Moreover, by etching a matching slot with steps of equal width 1 mm and height 0.5 mm in the ground, ultra impedance wideband characteristic covering 3.1GHz to 13GHz is achieved. A 50-Ohm feed line is connected to an impedance transformer, which can improve the matching property furthermore.

2.2. Equivalent Circuit Model Analysis

The real and imaginary parts of input impedance simulated by HFSS software package are displayed in Fig. 2. As is seen, several resonance points are stimulated at the range of 3.1–13 GHz, while three extra resonant modes are generated at 1.78, 2.15, and 2.4 GHz. The simulated current distributions of the proposed antenna are also depicted in Fig. 2 to study the electromagnetic mechanism of the band-added operation. Obviously, there are dense current distributions on CLLR 1 at 1.78 GHz, on CLLR 2 at 2.15 GHz, and on CLLR 3 at 2.4 GHz, which cause the impedance variations to form the added bands.

Equivalent circuit model of the proposed antenna is carried out to comprehend the design mechanism. Conventionally, patch in small bandwidth antenna can be considered as an R-L-C parallel equivalent circuit. For UWB property, matching bandwidth can be considered as the result of several adjacent resonances and each one can be represented by an R-L-C parallel circuit [12]. The probe inductance is represented by L_{in} . In this article, resonances in GSM band (1.78 GHz), WCDMA band (2.15 GHz), and WLAN band (2.4 GHz) can also be regarded as three R-L-C parallel circuits. The inductance is determined by the length of the three folded CLLRs. And the capacitance is determined by the CLLRs' internal property and locations. As shown in Fig. 3, a multi-band property can be formed by connecting the above R-L-C circuit elements in series. The input impedance of the

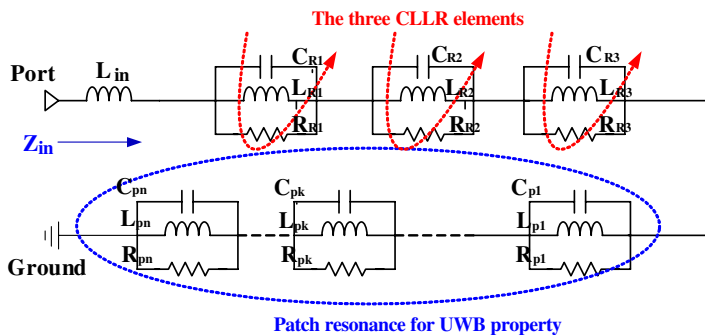

Figure 3. Equivalent circuit model for the proposed patch antenna.

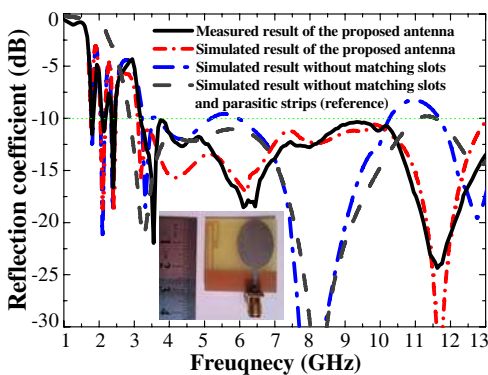

Figure 4. Simulated and measured reflection coefficient of the proposed and reference antenna.

antenna can be expressed as [12]:

$$Z_{in} = j\omega L_{in} + \sum_{k=1}^3 \frac{jR_{Rk}L_{Rk}\omega}{R_{Rk}(1 - \omega^2 L_{Rk}C_{Rk}) + j\omega L_{Rk}} + \sum_{k=1}^n \frac{jR_{pk}L_{pk}\omega}{R_{pk}(1 - \omega^2 L_{pk}C_{pk}) + j\omega L_{pk}} \quad (1)$$

3. SIMULATION RESULT DISCUSSION AND EXPERIMENTAL VERIFICATION

The simulated and measured reflection coefficient (S_{11}) results of the proposed quad-band UWB antenna are exhibited in Fig. 4, while the primary UWB antennas without CLLRs or matching slot are also given

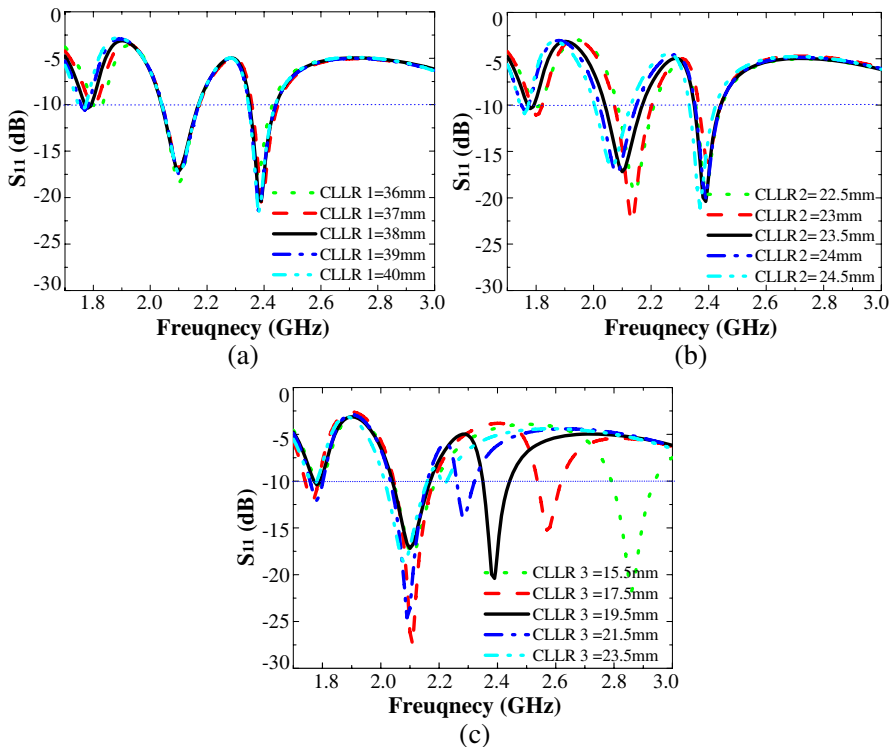

Figure 5. Simulated S_{11} curves at the added bands for different values of CLLRs. (a) CLLR 1. (b) CLLR 2. (c) CLLR 3.

as a reference. It can be seen from the comparison that, three extra communication bands can be achieved by introducing the proposed CLLR structures into the original UWB antenna. Besides, it is noticed the matching slot can improve antenna's S_{11} performance from the curves. The measured result clearly indicates that the proposed antenna provides a wide impedance bandwidth ($S_{11} < -10$ dB) of 3.1–13 GHz with triple narrow extra bands in 1.77–1.83 GHz, 2.08–2.19 GHz and 2.34–2.47 GHz, covering part of GSM, WCDMA and WLAN successfully. A reasonable agreement is obtained between the simulated and measured S_{11} curves, except for an acceptable frequency discrepancy, which may be caused by the fabrication error.

For further investigation, the effects of vital parameters of the meandered CLLR structures on the band-added characteristics are discussed. Fig. 5 shows the effects of various dimensions of CLLR cells on the added bands. Fig. 5(a) exhibits the effect of different lengths of CLLR 1 on S_{11} . As it increases, the corresponding resonant frequency for GSM shifts lower while the other added resonance bands are almost unchanged. The effect of CLLR 2 on S_{11} is shown in Fig. 5(b). It can be observed that the resonant frequency for WCDMA decreases as the length increases. Besides, the resonances of WLAN and GSM also shift toward lower frequencies a little as the CLLR 2's length increases, due to the coupling and interaction between the adjacent

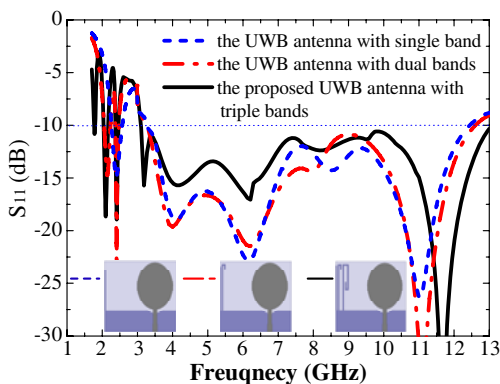

Figure 6. Simulated S_{11} curves for the UWB antenna integrated with single-, dual-, triple-bands.

Table 1. Measured peak gain of the proposed antenna.

Frequency (GHz)	1.78	2.15	2.4	3	6	9	12
Peak Gain (dBi)	-3.5	-1	-0.6	1.5	4.8	6	5.4

CLLR structures. It is clearly seen from Fig. 5(c) that the length of CLLR 3 has a significant effect on the added resonant frequency for WLAN applications with little influence on the WCDMA and GSM bands. From Fig. 5, it can be seen that the individual added wireless bands are mainly controlled by the corresponding CLLRs. Therefore, we can easily change their dimensions for the desired applications without the need to redesign the whole antenna. It should be noted that the couplings among the different strips also have some affections

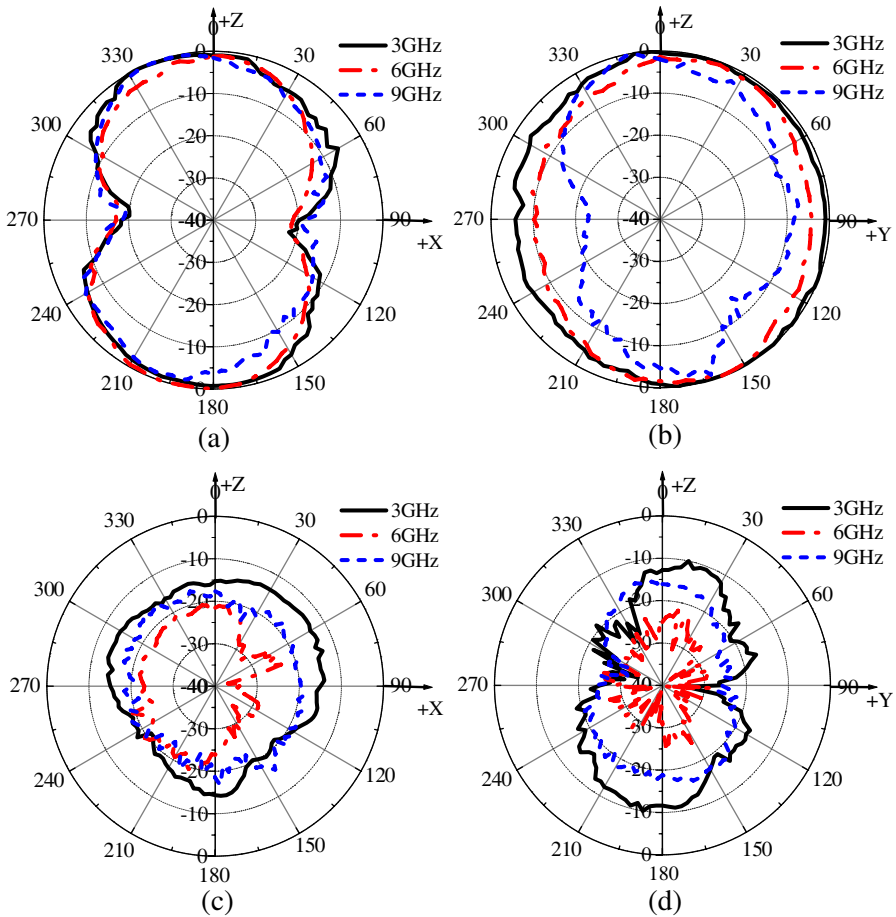

Figure 7. Measured co-polarization and cross-polarization radiation patterns (Unit: dBi). (a) Co-polarization component in E -plane, (b) co-polarization component in H -plane, (c) cross-polarization component in E -plane, (d) cross-polarization component in H -plane.

on the final design, which can be considered and implemented by the small parameter adjustment in HFSS software.

Additionally, the small size UWB antennas integrated with single-, and dual-lower bands can be achieved by using the similar method. To achieve a UWB antenna with single extra band, only CLLR 3 is needed. After optimizing, the single CLLR cell is designed with the length of 17 mm for 2.4 GHz, as shown in Fig. 6. Dual extra bands can be obtained by introducing CLLR 3 and 2. We set the two CLLRs with the length of 19 and 23.5 mm to obtain the WLAN and WCDMA bands.

The measured radiation patterns of the proposed antenna, including co-polarization and cross-polarization components, at 3, 6 and 9 GHz in x - z plane and y - z plane are shown in Fig. 7. The antenna patterns are almost bidirectional in x - z plane (E -plane) from Fig. 7(a). In y - z plane (H -plane), antenna radiates towards the $+Y$ -direction, turning into a directed antenna from Fig. 7(b). In Fig. 7, it is seen good linear polarization is realized according to the comparison of co-polarization and cross-polarization components. This is caused by antenna's asymmetrical structure. The UWB behavior of the antenna could be further improved by introducing CLLRs while preserving the symmetry of the antenna geometry. This will be studied in the future. Table 1 illustrates the measured peak gains of the proposed antenna. It is observed that the gains in extra bands are relatively low because the radiations on CLLRs are weak compared with main radiation element.

The variation of group delay is also an important parameter for UWB application. It must keep a relatively consistent value to ensure the transmission of UWB pulses with minimum distortion. The group delay of the proposed quad-band antenna (including UWB and

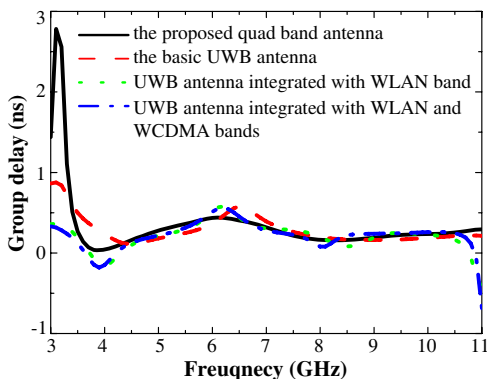

Figure 8. The group delay of the proposed and reference antennas.

GSM/WCDMA/WLAN bands) is shown in Fig. 8. The group delays are almost flat over UWB frequencies with a small pulse distortion in the lower UWB operated band. The result indicates that the proposed antenna has good time/frequency characteristics and some level of distortion. Therefore the antenna can be used in pulsed cognitive radio applications. Besides, the group delays of three reference antennas noted in Fig. 8 are given as comparison, which are all flat with variations below 1ns, suitable for UWB operation.

4. CONCLUSION

An approach for a compact UWB antenna design with extra triple bands has been proposed. The design methodology is simply utilizing an ellipse-shaped monopole to obtain UWB property. Three more effective and controllable communication bands are stimulated by properly tuning dimensions of quarter-wavelength CLLRs on ground. The measured results of the fabricated antenna show a directed radiation over the whole UWB band. Good agreement is observed between measured and simulated results, demonstrating the proposed antenna a good candidate for multi-band applications. It should be noted that by using our proposed method of introducing extra parasitic resonating strips, other extra wireless communication bands such as LTE700/GSM850/GSM900 can also be achieved to integrate with UWB antenna.

ACKNOWLEDGMENT

This work is supported by the NSFC under Contract No. 61101066 and Foundation for the Returned Overseas Chinese Scholars, Shaanxi Province and State Education Ministry, and partially supported by the Program for New Century Excellent Talents in University of China, the NSFC under Contract No. 61072017, Natural Science Basic Research Plan in Shaanxi Province of China (No. 2010JQ8013), Fundamental Research Funds for the Central Universities.

REFERENCES

1. Islam, M. T., R. Azim, and A. T. Mobashsher, "Triple band-notched planar UWB antenna using parasitic strips," *Progress In Electromagnetics Research*, Vol. 129, 161–179, 2012.
2. Lizzi, L., G. Oliveri, and A. Massa, "A time-domain approach to the synthesis of UWB antenna systems," *Progress In Electromagnetics Research*, Vol. 122, 557–575, 2012.

3. Xu, H. Y., H. Zhang, K. Lu, and X. F. Zeng, "A holly-leaf-shaped monopole antenna with low RCS for UWB application," *Progress In Electromagnetics Research*, Vol. 117, 35–50, 2011.
4. Li, C. M. and L. H. Ye, "Improved dual band-notched UWB slot antenna with controllable notched bandwidths," *Progress In Electromagnetics Research*, Vol. 115, 477–493, 2011.
5. Saleem, R. and A. K. Brown, "Empirical miniaturization analysis of inverse parabolic step sequence based UWB antennas," *Progress In Electromagnetics Research*, Vol. 114, 369–381, 2011.
6. Zhang, Z. and Y. H. Lee, "A robust cad tool for integrated design of UWB antenna system," *Progress In Electromagnetics Research*, Vol. 112, 441–457, 2011.
7. Yildirim, B. S., B. A. Cetiner, G. Roqueta, and L. Jofre, "Integrated bluetooth and UWB antenna," *IEEE Antennas Wireless Propag. Lett.*, Vol. 8, 149–152, 2009.
8. Mishra, S. K., R. K. Gupta, A. Vaidya, and J. Mukherjee, "A compact dual-band fork-shaped monopole antenna for Bluetooth and UWB applications," *IEEE Antennas Wireless Propag. Lett.*, Vol. 10, 627–630, 2011.
9. Foudazi, A., H. R. Hassani, and S. M. Ali Nezhad, "Small UWB planar monopole antenna with added GPS/GSM/WLAN bands," *IEEE Trans. Antennas Propag.*, Vol. 60, No. 6, 2987–2992, 2012.
10. Bod, M., H. R. Hassani, and M. M. Samadi Taheri, "Compact UWB printed slot antenna with extra bluetooth, GSM, and GPS bands," *IEEE Antennas Wireless Propag. Lett.*, Vol. 11, 531–534, 2012.
11. Rahanandeh, M., A. S. Noor Amin, M. Hosseinzadeh, P. Rezai, and M. S. Rostami, "A compact elliptical slot antenna for covering bluetooth/WiMAX/WLAN/ITU," *IEEE Antennas Wireless Propag. Lett.*, Vol. 11, 857–860, 2012.
12. Pele, I., A. Chousseaud, and S. Toutain, "Simultaneous modeling of impedance and radiation pattern antenna for UWB pulse modulation," *Proc. IEEE AP-S Int. Symp.*, Vol. 2, 1871–1874, 2004.